

## DUAL OPERATIONAL AMPLIFIER

### DESCRIPTION

The RC4558 is a monolithic integrated circuit designed for dual operational amplifier.

### FEATURES

- \* No frequency compensation required
- \* No latch-up
- \* Large common mode and differential voltage range
- \* Parameter tracking over temperature range
- \* Gain and phase match between amplifiers
- \* Internally frequency compensated
- \* Low noise input transistors

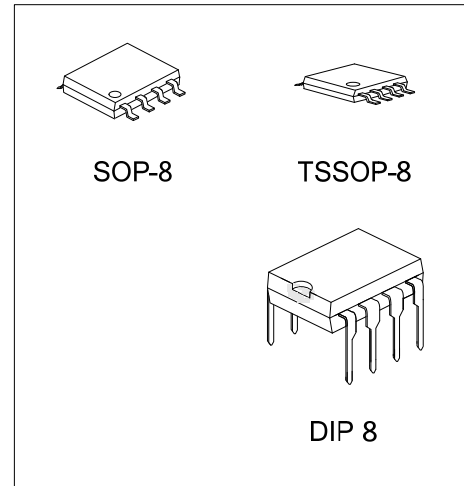

### PIN CONFIGURATIONS

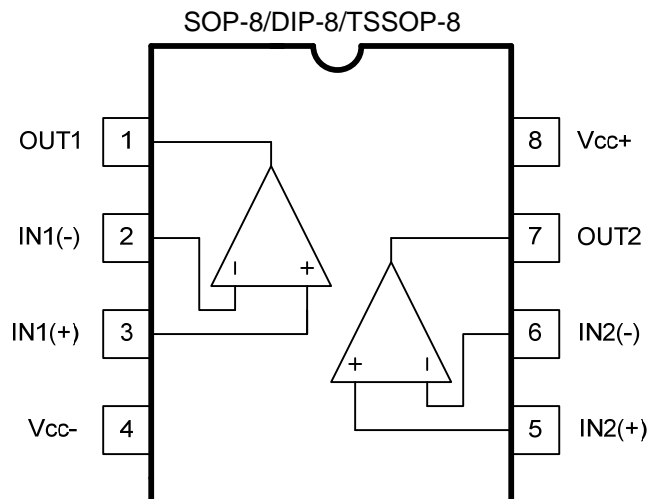

**■ ABSOLUTE MAXIMUM RATINGS**

PARAMETER	SYMBOL	RATING	UNIT
Supply Voltage	$V_{CC}$	$\pm 22$	V
Differential input voltage	$V_{I(DIFF)}$	$\pm 18$	V
Power Dissipation	DIP-8	600	mW
	SOP-8	400	mW
	TSSOP-8	250	mW
Input Voltage	$V_{IN}$	$\pm 15$	V
Junction Temperature	$T_J$	+125	°C
Operating Temperature	$T_{OPR}$	-20 ~ +85	°C
Storage Temperature	$T_{STG}$	-40 ~ +150	°C

Note 1. Absolute maximum ratings are those values beyond which the device could be permanently damaged. Absolute maximum ratings are stress ratings only and functional device operation is not implied.

2. The device is guaranteed to meet performance specification within 0°C ~ +70°C operating temperature range and assured by design from -20°C ~ +85°C.

**■ ELECTRICAL CHARACTERISTICS (Ta=25°C, V<sub>CC</sub>=15V, V<sub>ee</sub>=-15V)**

PARAMETER	SYMBOL	TEST CONDITIONS	MIN	TYP	MAX	UNIT
Supply Current, all Amp, no load	$I_{CC}$			2.3	4.5	mA
Input offset voltage	$V_{I(OFF)}$	$R_S < 10k\Omega$		2	6	mV
Input offset current	$I_{I(OFF)}$			5	200	nA
Input bias current	$I_{I(BIAS)}$			30	500	nA
Large signal voltage gain	$G_V$	$V_{O(p-p)} = \pm 10V, R_L \leq 2k\Omega$	20	200		V/mV
Common Mode Input Voltage Range	$V_{I(COM)}$		$\pm 12$	$\pm 13$		V
Common Mode Rejection Ratio	$RR_{(COM)}$	$R_S \leq 10k\Omega$	70	90		dB
Supply Voltage Rejection Ratio	$RR_{(VCC)}$	$R_S \leq 10k\Omega$	76	90		dB
Output Voltage swing	$V_{O(p-p)}$	$R_L \geq 10k\Omega$	$\pm 12$	$\pm 14$		V
Power Consumption	$P_C$			70	170	mW
Slew Rate	SR	$V_{IN} = \pm 10V, R_L \geq 2k\Omega, C_L \leq 100pF$	1.2	2.2		V/ $\mu s$
Rise Time	$T_{RIS}$	$V_{IN} = \pm 20mV, R_L \geq 2k\Omega, C_L \leq 100pF$		0.3		$\mu s$
Overshoot	OS	$V_{IN} = \pm 20mV, R_L \geq 2k\Omega, C_L \leq 100pF$		15		%
Input Resistance	$R_{IN}$		0.3	2		M $\Omega$
Output Resistance	$R_{OUT}$			75		$\Omega$
Total Harmonic Distortion	THD	$f=1kHz, A_v=20dB, R_L=2k\Omega, V_{OUT}=2V_{pp}, C_L=100pF$		0.008		%
Channel Separation	$V_{O1}/V_{O2}$			120		dB
<b>FREQUENCY CHARACTERISTIC</b>						
Unity Gain Bandwidth	BW		2.0	2.8		MHz

■ BLOCK DIAGRAM

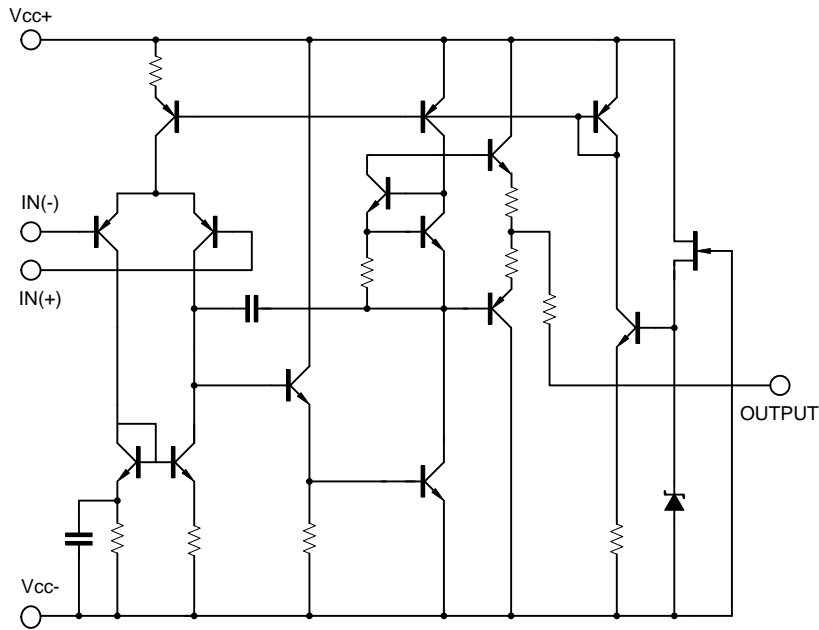

■ TYPICAL CHARACTERISTICS

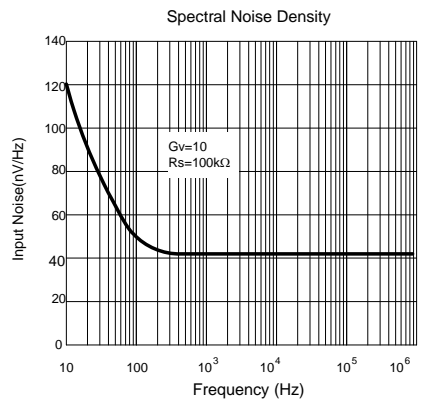
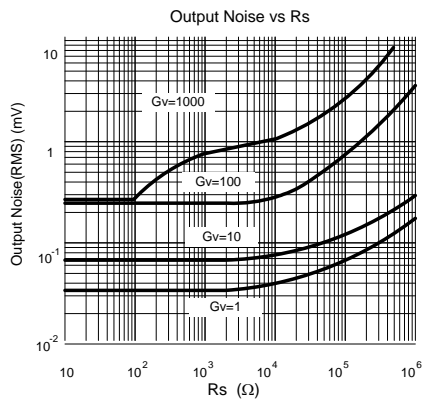
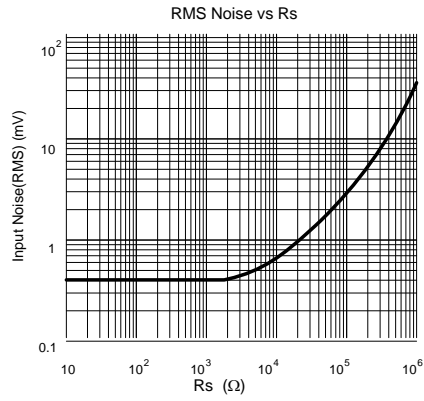
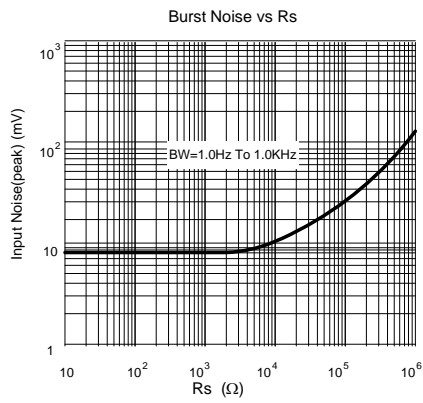

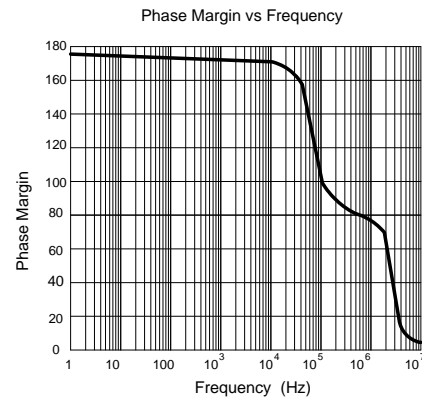
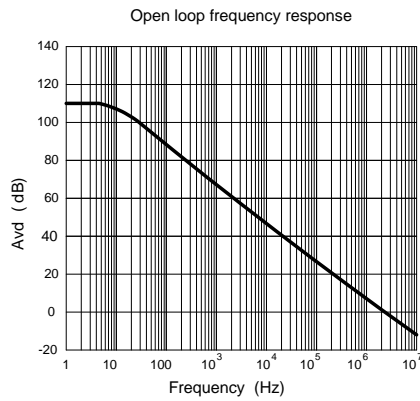

■ TYPICAL CHARACTERISTICS(Cont.)

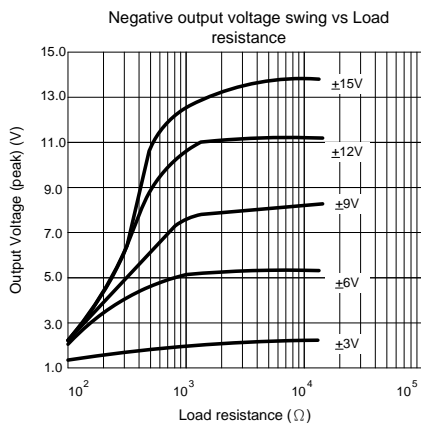
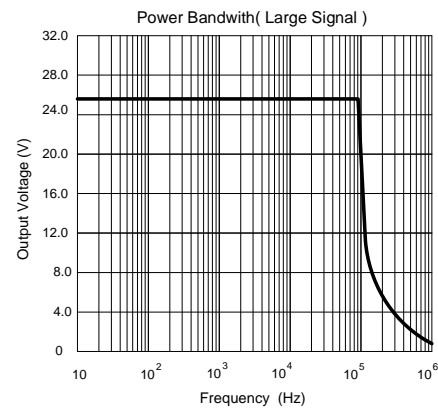
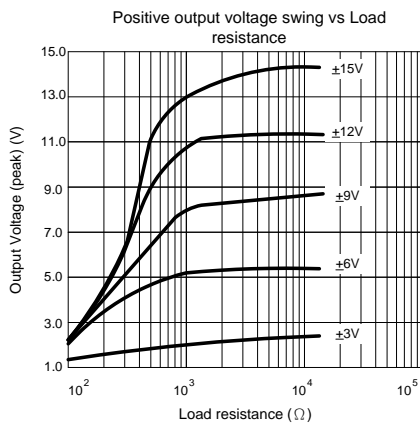

Important statement:

Huaguan Semiconductor Co,Ltd. reserves the right to change the products and services provided without notice. Customers should obtain the latest relevant information before ordering, and verify the timeliness and accuracy of this information.

Customers are responsible for complying with safety standards and taking safety measures when using our products for system design and machine manufacturing to avoid potential risks that may result in personal injury or property damage.

Our products are not licensed for applications in life support, military, aerospace, etc., so we do not bear the consequences of the application of these products in these fields.

Our documentation is only permitted to be copied without any tampering with the content, so we do not accept any responsibility or liability for the altered documents.

## X-ON Electronics

Largest Supplier of Electrical and Electronic Components

*Click to view similar products for [Operational Amplifiers - Op Amps](#) category:*

*Click to view products by [HGSEMI](#) manufacturer:*

Other Similar products are found below :

[OPA2991IDSGR](#) [OPA607IDCKT](#) [007614D](#) [633773R](#) [635798C](#) [635801A](#) [702115D](#) [709228FB](#) [741528D](#) [NCV33072ADR2G](#)  
[SC2902DTBR2G](#) [SC2903DR2G](#) [SC2903VDR2G](#) [LM258AYDT](#) [LM358SNG](#) [430227FB](#) [430228DB](#) [460932C](#) [AZV831KTR-G1](#) [409256CB](#)  
[430232AB](#) [LM2904DR2GH](#) [LM358YDT](#) [LT1678IS8](#) [042225DB](#) [058184EB](#) [070530X](#) [SC224DR2G](#) [SC239DR2G](#) [SC2902DG](#)  
[SCYA5230DR2G](#) [714228XB](#) [714846BB](#) [873836HB](#) [MIC918YC5-TR](#) [TS912BIYDT](#) [NCS2004MUTAG](#) [NCV33202DMR2G](#)  
[M38510/13101BPA](#) [NTE925](#) [SC2904DR2G](#) [SC358DR2G](#) [LM358EDR2G](#) [AZV358MTR-G1](#) [AP4310AUMTR-AG1](#) [HA1630D02MMEL-E](#)  
[NJM358CG-TE2](#) [HA1630S01LPEL-E](#) [LM324AWPT](#) [HA1630Q06TELL-E](#)