

## DUAL OPERATIONAL AMPLIFIER

### GENERAL DESCRIPTION

The RC4560 integrated circuit is a high-gain, wide bandwidth, dual operational amplifier capable of driving 20V peak-to-peak into 400 loads. The RC4560 combines many of the features of the HG4558 as well as providing the capability of wider bandwidth, and higher slew rate make the RC4560 ideal for active filters, data and telecommunications, and many instrumentation applications.

### FEATURES

- Operating Voltage: ( $\pm 4\text{ V} \sim \pm 18\text{ V}$ )
- Wide Gain Bandwidth Product: (10 MHz typ.)
- Slew Rate: (4 V/s typ.)
- Bipolar Technology

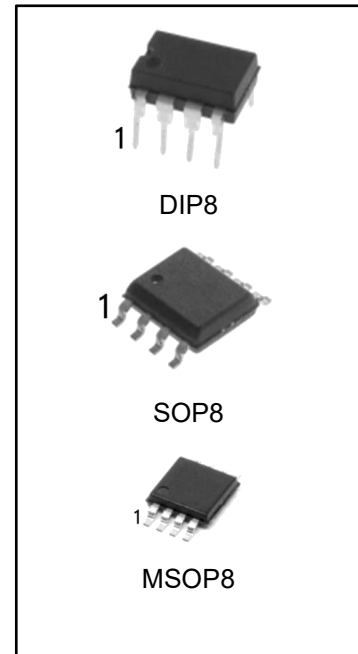

### ORDERING INFORMATION

DEVICE	Package Type	MARKING	Packing	Packing Qty
RC4560N	DIP8L	RC4560	TUBE	2000pcs/box
RC4560M/TR	SOP8L	RC4560	REEL	2500pcs/reel
RC4560MM/TR	MSOP8L	RC4560	REEL	3000pcs/reel

### BLOCK DIAGRAM

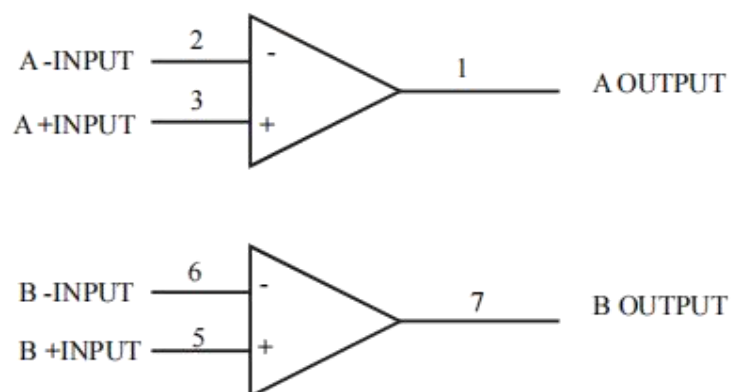
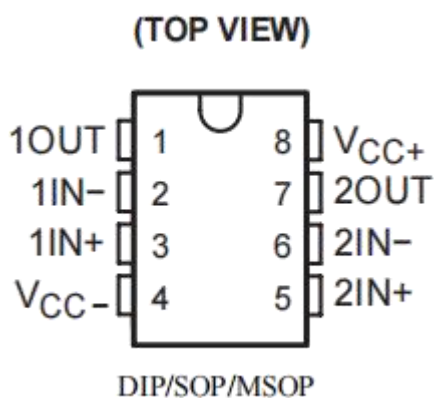

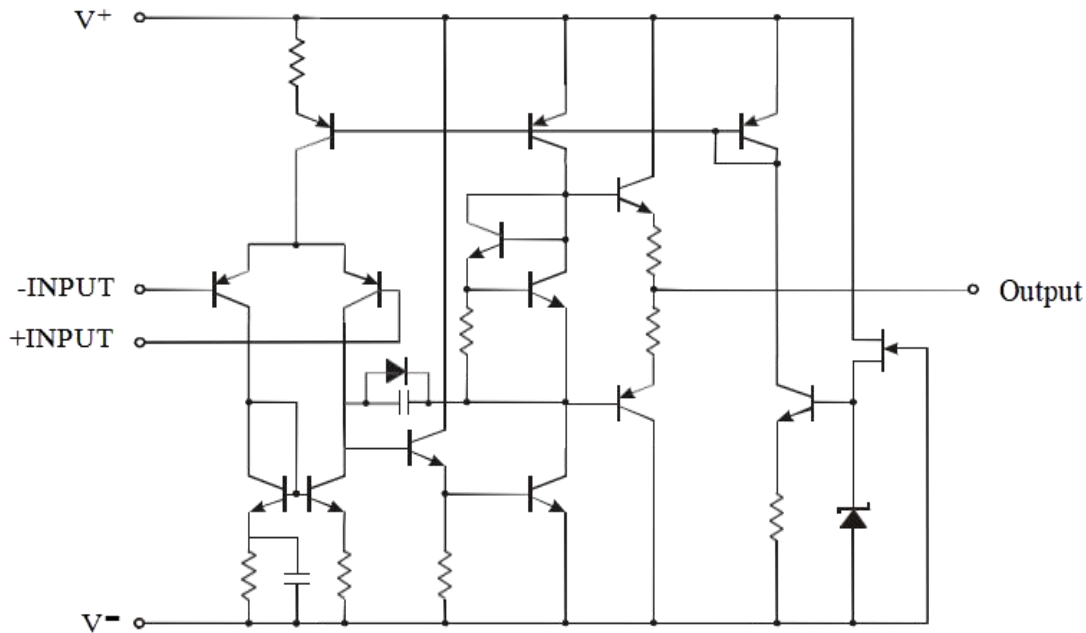
**EQUIVALENT CIRCUIT (1/2 Show)**

**ABSOLUTE MAXIMUM RATINGS (Ta=25°C)**

Symbol	Parameter	Ratings	Unit
V <sup>+</sup> /V <sup>-</sup>	Supply Voltage	18	V
V <sub>ID</sub>	Differential Input Voltage	30	V
V <sub>IC</sub>	Input Voltage	15*	V
Topr	Operation Temperature Range	-25~+75	°C
Tstg	Storage Temperature Range	-60~+125	°C

\* For supply voltage less than 15 V, the absolute maximum input voltage is equal to the supply voltage.

**ELECTRICAL CHARACTERISTICS**

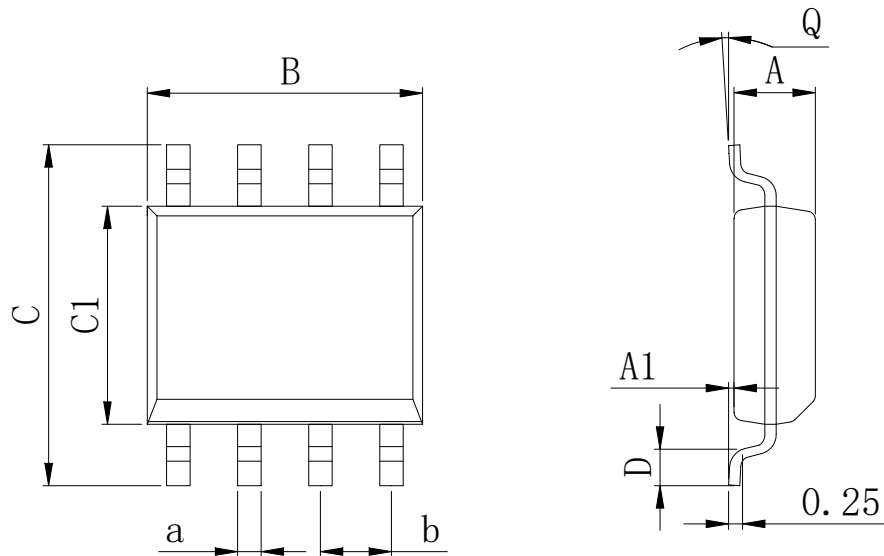
Symbol	Parameter	Test Condition	Min	Max	Unit
V <sub>IO</sub>	Input Offset Voltage	R <sub>S</sub> ≤ 10 kΩ	-	6	mV
I <sub>IO</sub>	Input Offset Current		-	200	nA
I <sub>B</sub>	Input Bias Current		-	500	nA
R <sub>IN</sub>	Input Resistance		0.3	-	MΩ
A <sub>v</sub>	Large Signal Voltage Gain	R <sub>L</sub> ≥ 2 kΩ, V <sub>O</sub> = ±10 V	86	-	dB
V <sub>OM1</sub>	Maximum Output Voltage Swing 1	R <sub>L</sub> ≥ 2 kΩ	±12	-	V
V <sub>OM2</sub>	Maximum Output Voltage Swing 2	I <sub>o</sub> = 25 mA	±10	-	V
V <sub>ICM</sub>	Input Common Mode Voltage Range		±12	-	V
CMR	Common Mode Rejection Ratio	R <sub>S</sub> ≤ 10 kΩ	70	-	dB
SVR	Supply Voltage Rejection Ratio	R <sub>S</sub> ≤ 10 kΩ	76.5	-	dB
I <sub>CC</sub>	Operating Current		-	5.7	mA
SR	Slew Rate	R <sub>L</sub> ≥ 2 kΩ	3	5	V/μs

**PHYSICAL DIMENSIONS**
**SOP8**

**Dimensions In Millimeters(SOP8)**

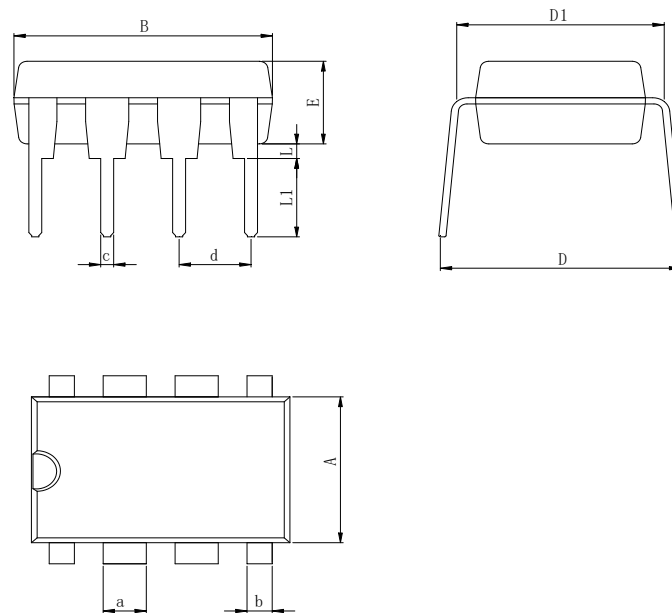
Symbol:	A	A1	B	C	C1	D	Q	a	b
Min:	1.35	0.05	4.90	5.80	3.80	0.40	0°	0.35	1.27 BSC
Max:	1.55	0.20	5.10	6.20	4.00	0.80	8°	0.45	

**DIP8**

**Dimensions In Millimeters(DIP8)**

Symbol:	A	B	D	D1	E	L	L1	a	b	c	d
Min:	6.10	9.00	8.40	7.42	3.10	0.50	3.00	1.50	0.85	0.40	2.54 BSC
Max:	6.68	9.50	9.00	7.82	3.55	0.70	3.60	1.55	0.90	0.50	

**PHYSICAL DIMENSIONS**

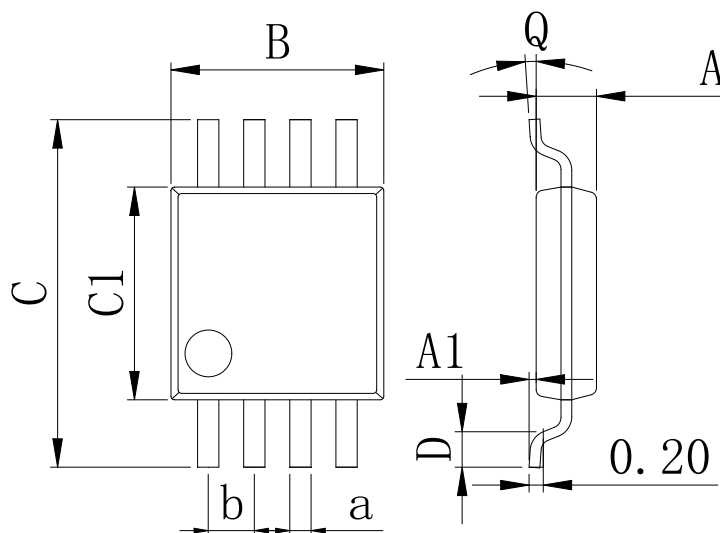
MSOP8



Dimensions In Millimeters(MSOP8)									
Symbol:	A	A1	B	C	C1	D	Q	a	b
Min:	0.80	0.05	2.90	4.75	2.90	0.35	0°	0.25	0.65 BSC
Max:	0.90	0.20	3.10	5.05	3.10	0.75	8°	0.35	

**IMPORTANT STATEMENT:**

Huaguan Semiconductor reserves the right to change its products and services without notice. Before ordering, the customer shall obtain the latest relevant information and verify whether the information is up to date and complete. Huaguan Semiconductor does not assume any responsibility or obligation for the altered documents.

Customers are responsible for complying with safety standards and taking safety measures when using Huaguan Semiconductor products for system design and machine manufacturing. You will bear all the following responsibilities: select the appropriate Huaguan Semiconductor products for your application; Design, validate and test your application; Ensure that your application meets the appropriate standards and any other safety, security or other requirements. To avoid the occurrence of potential risks that may lead to personal injury or property loss.

Huaguan Semiconductor products have not been approved for applications in life support, military, aerospace and other fields, and Huaguan Semiconductor will not bear the consequences caused by the application of products in these fields.

The technical and reliability data (including data sheets), design resources (including reference designs), application or other design suggestions, network tools, safety information and other resources provided for the performance of semiconductor products produced by Huaguan Semiconductor are not guaranteed to be free from defects and no warranty, express or implied, is made. The use of testing and other quality control technologies is limited to the quality assurance scope of Huaguan Semiconductor. Not all parameters of each device need to be tested.

The documentation of Huaguan Semiconductor authorizes you to use these resources only for developing the application of the product described in this document. You have no right to use any other Huaguan Semiconductor intellectual property rights or any third party intellectual property rights. It is strictly forbidden to make other copies or displays of these resources. You should fully compensate Huaguan Semiconductor and its agents for any claims, damages, costs, losses and debts caused by the use of these resources. Huaguan Semiconductor accepts no liability for any loss or damage caused by infringement.

## X-ON Electronics

Largest Supplier of Electrical and Electronic Components

*Click to view similar products for [Operational Amplifiers - Op Amps](#) category:*

*Click to view products by [HGSEMI](#) manufacturer:*

Other Similar products are found below :

[SC2902DTBR2G](#) [430227FB](#) [UPC451G2-A](#) [UPC824G2-A](#) [LT1678IS8](#) [042225DB](#) [058184EB](#) [UPC822G2-A](#) [UPC258G2-A](#)  
[NCS5651MNTXG](#) [NCV33202DMR2G](#) [NJM324E](#) [NTE925](#) [5962-9080901MCA\\*](#) [AZV358MTR-G1](#) [AP4310AUMTR-AG1](#)  
[HA1630D02MMEL-E](#) [HA1630S01LPEL-E](#) [AZV358MMTR-G1](#) [SCY33178DR2G](#) [NJU77806F3-TE1](#) [NCV5652MUTWG](#) [NCV20034DR2G](#)  
[NTE778S](#) [NTE871](#) [NTE924](#) [NTE937](#) [MCP6V16UT-E/OT](#) [MCP6V17T-E/MS](#) [MCP6V19T-E/ST](#) [SCY6358ADR2G](#) [NCS20282FCTTAG](#)  
[UPC451G2-E2-A](#) [LM4565FVT-GE2](#) [EL5420CRZ-T7A](#) [TSV772IQ2T](#) [TSV792IYST](#) [NJM2100M-TE1](#) [AS324MTR-E1](#) [AS358MMTR-G1](#)  
[MCP6232T-EMNY](#) [MCP6471T-E/LTY](#) [MCP6472T-E/MS](#) [MCP6491T-ELTY](#) [MCP662-E/MF](#) [MCP6H02T-EMNY](#) [MCP6V07-EMD](#)  
[TLC073IDGQR](#) [TLC081AIP](#) [TLC082AIP](#)