

Pulse Width Modulation Control Circuit

Features

- 8.0V to 35V Operation
- 5.0V \pm 1% Trimmed Reference
- 1.0Hz to 400KHz Oscillator Range
- Dual Source/Sink Current Outputs: \pm 100mA
- Digital Current Limiting
- Programmable Dead Time
- Undervoltage-Lockout
- Single Pulse Metering
- Programmable Soft-Start
- Wide Current Limit Common Mode Range
- Guaranteed 6 Unit Synchronization

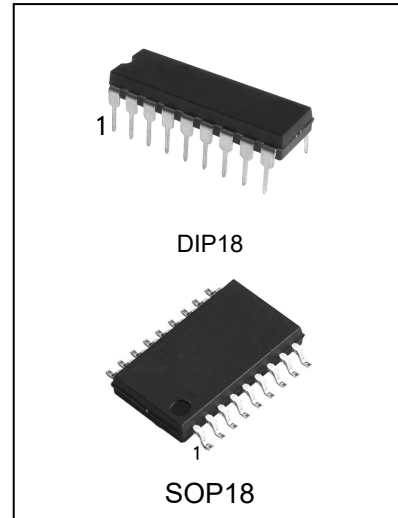

ORDERING INFORMATION

DEVICE	Package Type	MARKING	Packing	Packing Qty
SG3526N	DIP18	SG3526	TUBE	800pcs/box
SG3526M/TR	SOP18	SG3526	REEL	2500pcs/reel

General Description

The SG3526 is a high performance pulse width modulator integrated circuit intended for fixed frequency switching regulators and other power control applications.

Functions included in this IC are a temperature compensated voltage reference, sawtooth oscillator, error amplifier, pulse width modulator, pulse metering and steering logic, and two high current totem pole outputs ideally suited for driving the capacitance of power FETs at high speeds.

Additional protective features include soft start and undervoltage lockout, digital current limiting, double pulse inhibit, adjustable deadtime and a data latch for single pulse metering;. All digital control ports are TTL and B-series CMOS compatible. Active low logic design allows easy wired-OR connections for maximum flexibility. The versatility of this device enables implementation or transformer coupled.

Pin Configuration

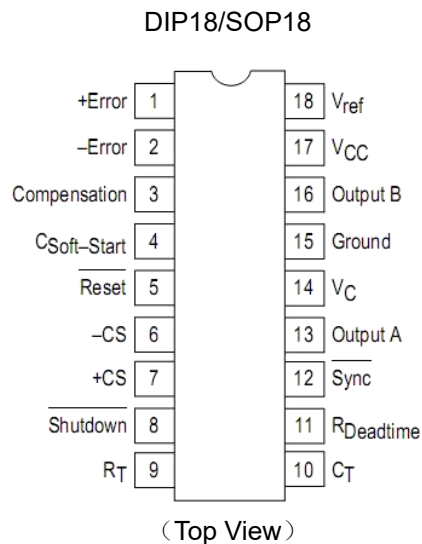

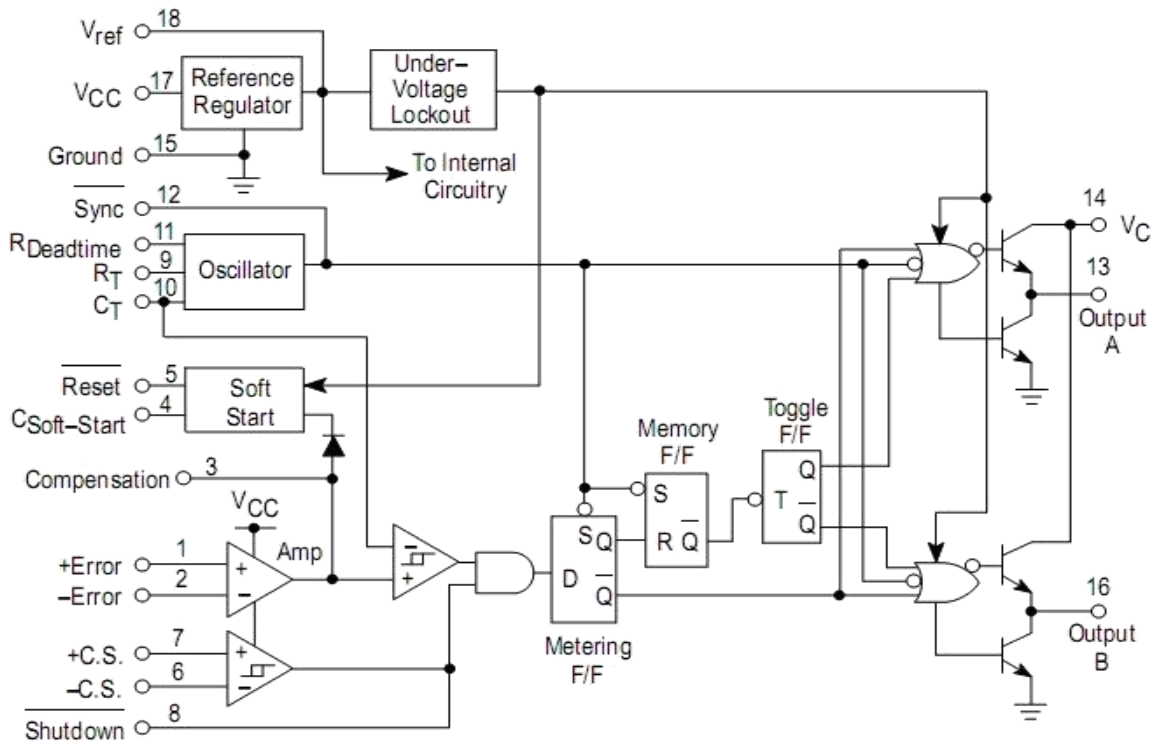
Representative Block Diagram

Maximum Ratings (Note1)

Rating	Symbol	Value	Unit
Supply Voltage	Vcc	+40	Vdc
Collector Supply Voltage	Vc	+40	Vdc
Logic Inputs		-0.3 to + 5.5	V
Analog Inputs		-0.3 to +5.5	V
Output Current,Source or Sink	Io	±200	mA
Reference Load Current(Vcc=40V Note2)	Iref	50	mA
Logic Sink Current		15	mA
Power Dissipation Ta=+25°C (note3)	Pd	1000	mW
Operating Temperature Range	Ta	0~70	°C
Storage Temperature Range	Tstg	-65 to +150	°C
Lead Temperature(Soldering, 10Seconds)	Tsolder	±300	°C

NOTES:

1. Values beyond which damage may occur.
2. Maximum junction temperature must be observed.
3. Derate at 10 mW/°C for ambient temperatures above +50°C.

Recommended Operating Conditions

Characteristics	Symbol	Min	Max	Unit
Supply Voltage	Vcc	8.0	35	Vdc
Collector Supply Voltage	Vc	4.5	35	Vdc
Output Sink/Source Current(Each Output)	Io	0	±100	mA
Reference Load Current	Iref	0	20	mA
Oscillator Frequency Range	Fosc	0.001	400	Khz
Oscillator Timing Resistor	Rt	2.0	150	KΩ
Oscillator Timing Capacitor	Ct	0.001	20	uF
Available Deadtime Range(40Khz)	-	3.0	50	%
Operating Junction Temperature Range	Tj	0	+125	°C

ELECTRICAL CHARACTERISTICS

(VCC = +15 Vdc, TJ = Tlow to Thigh [Note 4], unless otherwise noted.)

Characteristics	Symbol	Min	Typ	Max	Unit
Reference Section					
Reference Output Voltage(Tj=+25°C)	Vref	4.90	5.00	5.10	V
Line Regulation(+8.0V ≤Vcc≤+35V)	Regline	-	10	30	mV
Load Regulation (0mA≤IL≤20mA)	Regload	-	10	50	mV
Short Circuit Current(Vref=0V)	Isc	25	80	125	mA
Undervoltage Lockout					
Reset Output Voltage(Vref=+3.8V)		-	0.2	0.4	V
Reset Output Voltage(Vref=+4.8V)		2.4	4.8	-	V
Oscillator Section(Note5)					
Initial Accuracy(Tj=+25°C)		-	±3.0	±8.0	%
Frequency Stability over Power Supply Range (+8.0V ≤Vcc≤+35V)	$\Delta f_{osc}/\Delta V_{CC}$	-	0.5	1.0	%
Minimum Frequency (Rt=150Kohm,Ct=20uF)	Fmin	-	0.5	-	Hz
Maximum Frequency (Rt=2.0Kohm,Ct=0.001uF)	Fmax	400	-	-	KHz
Sawtooth Peak Voltage (Vcc=35V)	Vosc(p)	-	3.0	3.5	V
Sawtooth Valley Voltage(Vcc=8.0V)	Vosc(V)	0.45	0.8	-	V
Error Amplifier Section (note6)					
Input Offset Voltage	Vio	-	2.0	10	mV
Input Bias Current	Iib	-	-350	-2000	nA
Input Offset Current	Iio	-	35	200	nA
Characteristics	Symbol	Min	Typ	Max	Unit

DC Open Loop Gain($R_l \geq 10\text{Mohm}$)	A_v	60	72	-	dB
High Output Voltage ($V_{pin1}-V_{pin2} \geq +150\text{mV}$, $I_{source}=100\mu\text{A}$)	V_{oh}	3.6	4.2	-	V
Low Output Voltage ($V_{pin2}-V_{pin1} \geq +150\text{mV}$, $I_{sink}=100\mu\text{A}$)	V_{ol}	-	0.2	0.4	V
Common Mode Rejection Ratio($R_s \leq 2.0\text{Kohm}$)	CMRR	70	94	-	dB
Power Supply Rejection Ration($+12\text{V} \leq V_{cc} \leq +18\text{V}$)	PSRR	66	80	-	dB
PWM Comparator Section(Note5)					
Minimum Duty Cycle ($V_{compensation} = +0.4\text{V}$)	D_{cmin}	-	-	0	%
Maximum Duty Cycle ($V_{compensation} = +3.6\text{V}$)	D_{cmax}	45	49	-	%
Digital Ports(SYNC,SHUTDOWN,RESET)					
Output Voltage (High Logic Level) ($I_{source}=40\mu\text{A}$) (Low Logic Level) ($I_{sink}=3.6\text{mA}$)	V_{oh} V_{ol}	2.4 -	4.0 0.2	- 0.4	V
Input Current-High Logic Level (High Logic Level) ($V_{ih}=+2.4\text{V}$) (Low Logic Level) ($V_{il} = +0.4\text{V}$)	I_{ih} I_{il}	- -	-125 -225	-200 -360	μA
Current Limit Comparator Section(note7)					
Sense Voltage($R_s \leq 50 \Omega$)	V_{sense}	80	100	120	mA
Input Bias Current	I_{ib}	-	-3.0	-10	μA
Soft-Start Section					
Error Clamp Voltage(Reset= $+0.4\text{V}$)		-	0.1	0.4	V
Csoft-Start Charging Current(Reset= $+2.4\text{V}$)	I_{cs}	50	100	150	μA
Output Drivers (each output, $V_c = +15\text{Vdc}$) Unless otherwise noted.					
Output High Level $I_{source} = 20\text{mA}$ $I_{source} = 100\text{mA}$	V_{oh}	12.5 12	13.5 13	- -	V
Output Low Level $I_{sink} = 20 \text{mA}$ $I_{sink} = 100\text{mA}$	V_{ol}	- -	0.2 1.2	0.3 2.0	V
Collector Leakage, $V_c = +40\text{V}$	$I_c(\text{Leak})$	-	50	150	μA
Rise Time($C_L = 1000\text{pF}$)	T_r	-	0.3	0.6	μs
Fall Time ($C_L = 1000\text{pF}$)	T_f	-	0.1	0.2	μs
Supply Current (Shutdown = $+0.4\text{V}$, $V_{cc} = +35\text{V}$, $R_t = 4.12\text{K} \Omega$)	I_{cc}	-	18	30	mA

Notes:

- $T_{low} = 0^\circ\text{C}$ $T_{high} = +125^\circ\text{C}$
- $f_{osc} = 40\text{KHz}$ ($R_t = 4.12\text{k} \Omega \pm 1\%$, $C_T = 0.01\mu\text{F} \pm 1\%$, $R_D = 0 \Omega$)
- $0\text{V} \leq V_{CM} \leq +5.2\text{V}$
- $0\text{V} \leq V_{CM} \leq +12\text{V}$

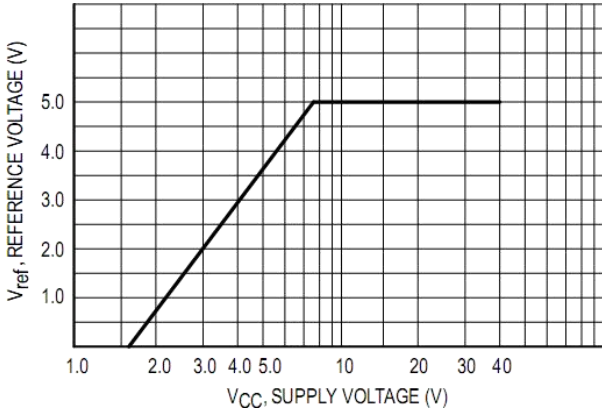

Reference Voltage as a Function Supply Votage

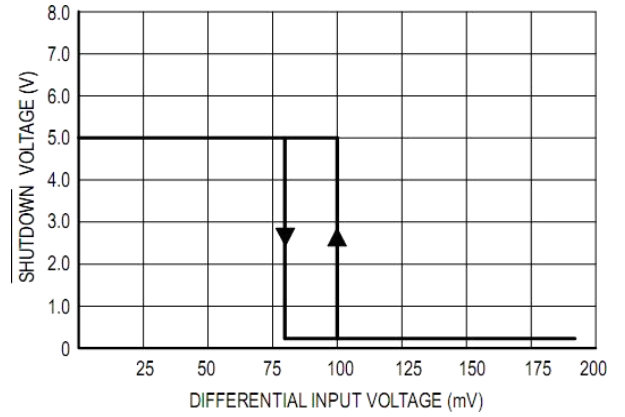

Current Limit Comparator Threshold

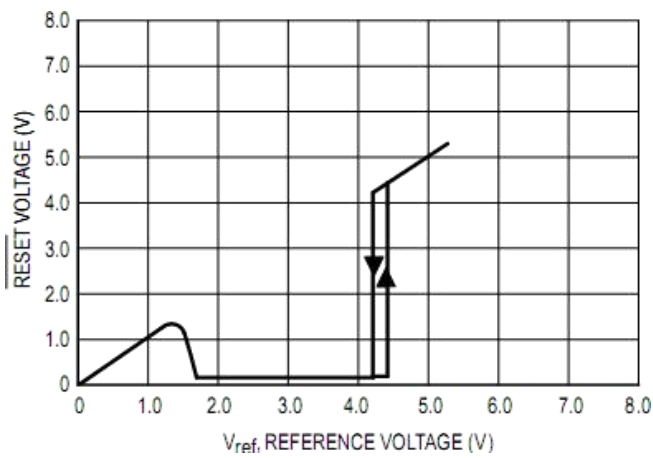

UnderVoltage Lockout Characteristic

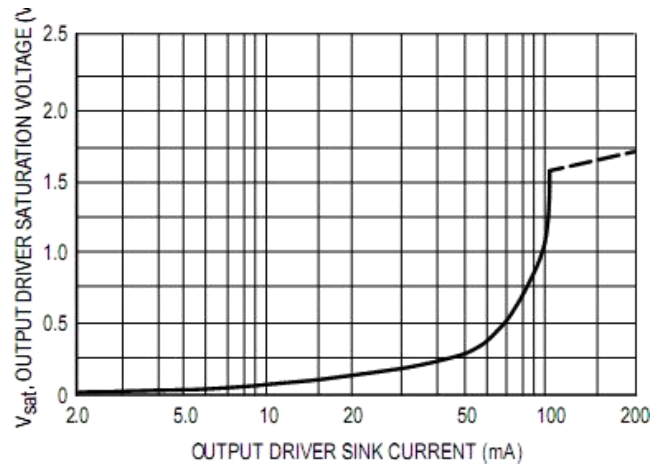

Output Driver Saturation Voltage as a Function of Sink Current

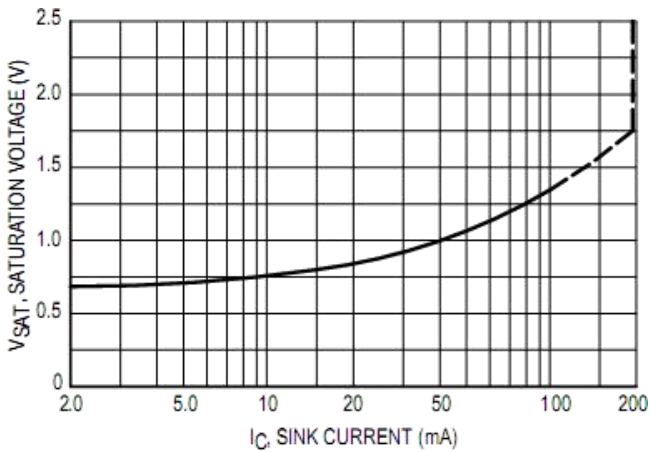

Vc Saturation Voltage as a Function of Sink Current

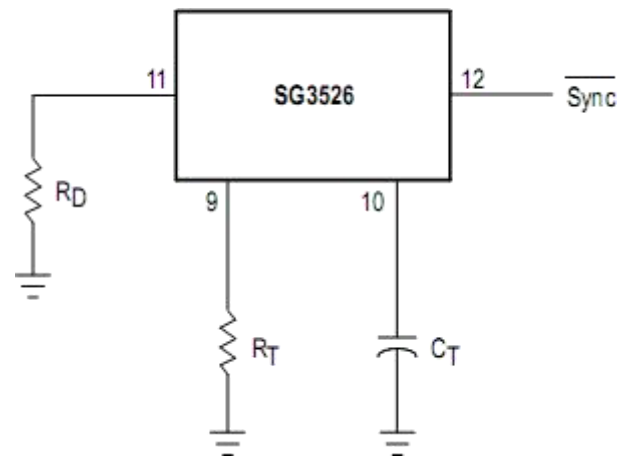

Oscillator Connections

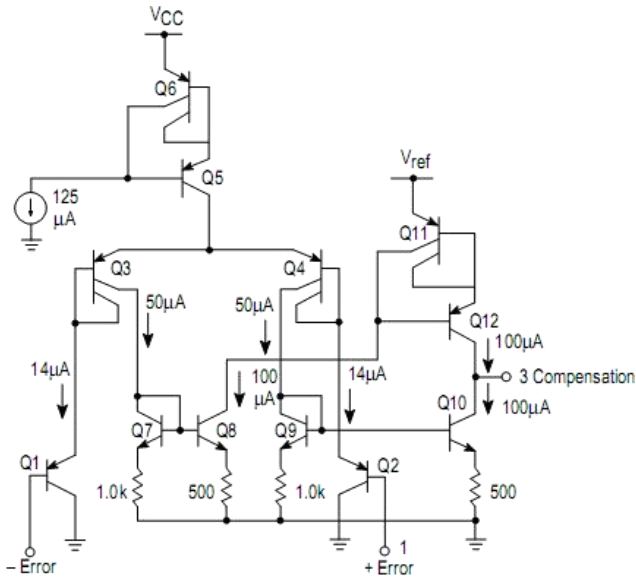

Error Amplifier

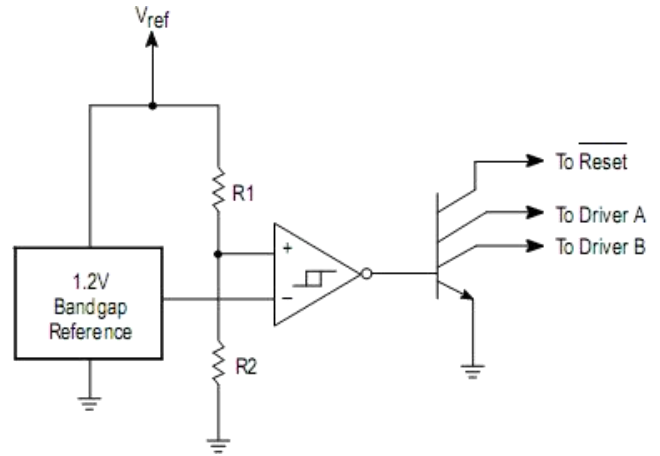

Undervoltage Lockout

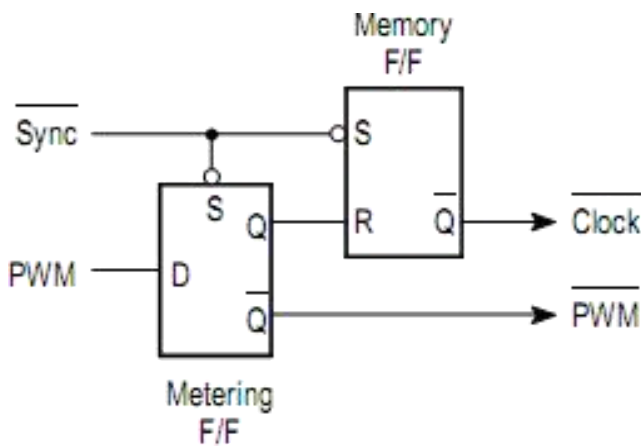

The metering Flip-Flop is an asynchronous data latch which suppresses high frequency oscillations by allowing only one PWM pulse per oscillator cycle.

The memory Flip-Flop prevents double pulsing in a push-pull configuration by remembering which output produced the last pulse.

Pulse Processing Logic

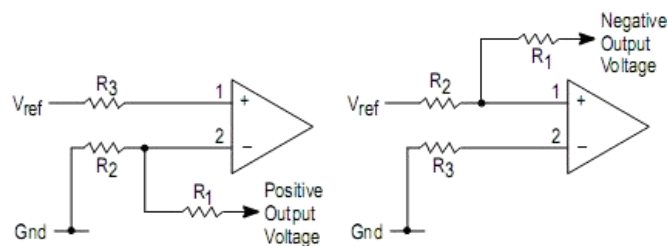

$$V_{out} = V_{ref} \left(\frac{R_1 + R_2}{R_2} \right)$$

$$V_{out} = V_{ref} \left(\frac{R_1}{R_2} \right)$$

$$R_3 = \left(\frac{R_1 R_2}{R_1 + R_2} \right)$$

Error Amplifier Connects

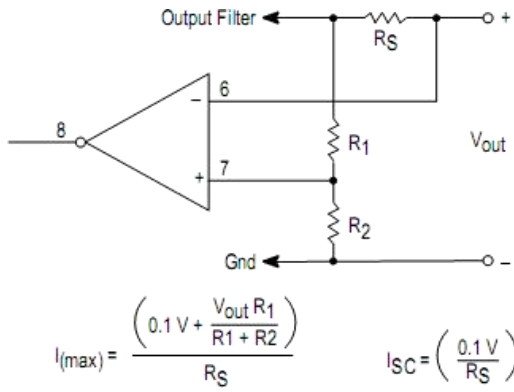

Foldback Current Limiting

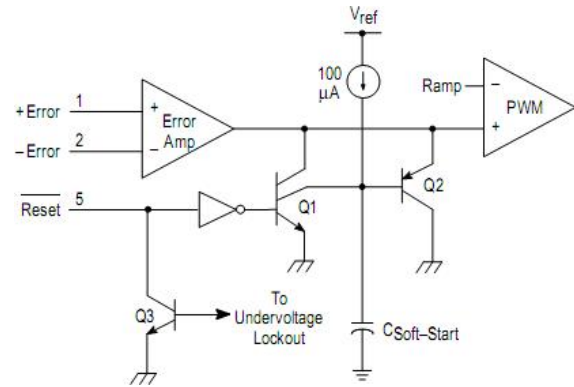

Soft-Start Circuitry

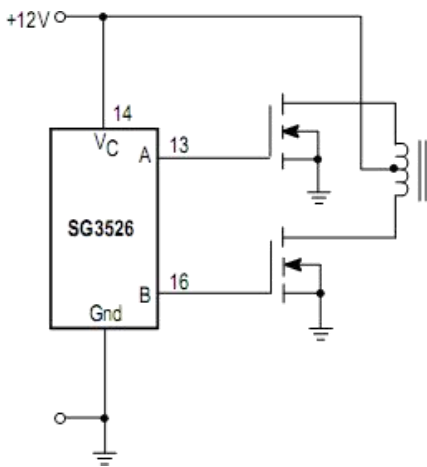

Driving VMOS Power FETs

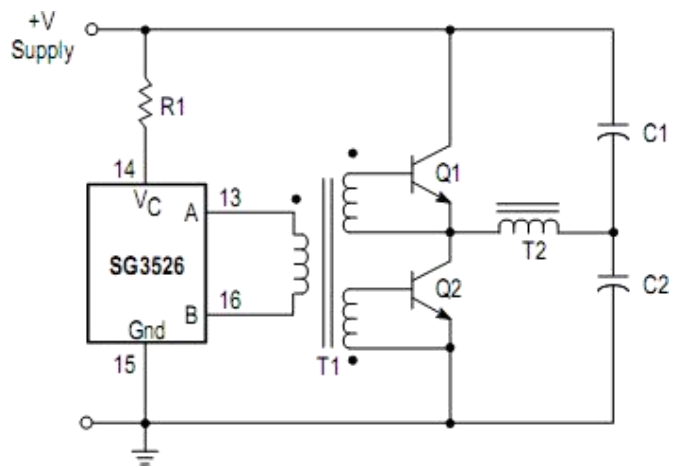

Half-Bridge Configuration

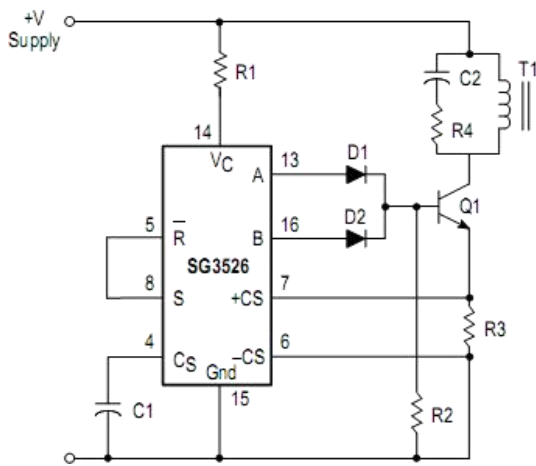

Flyback Converter with Current Limiting

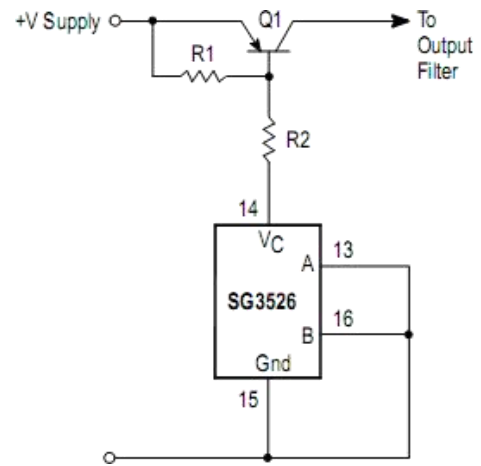

Single-Ended Configuration

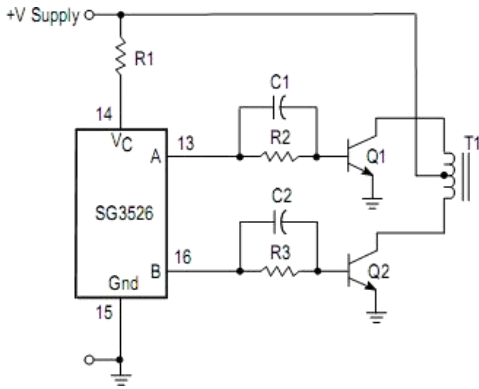

Push-Pull Configuration

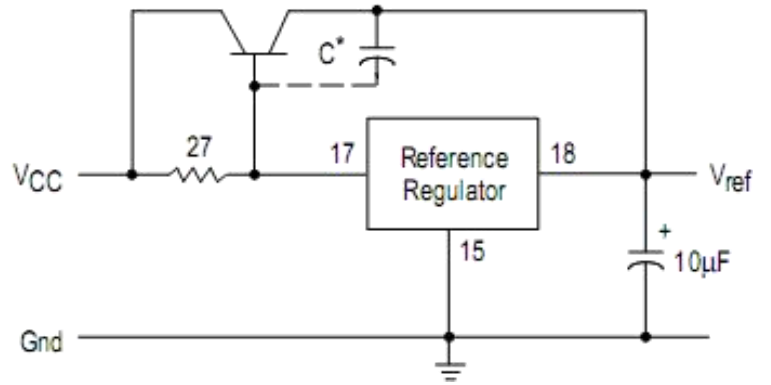

Extending Reference Output Current Capability

Package Information

SOP18

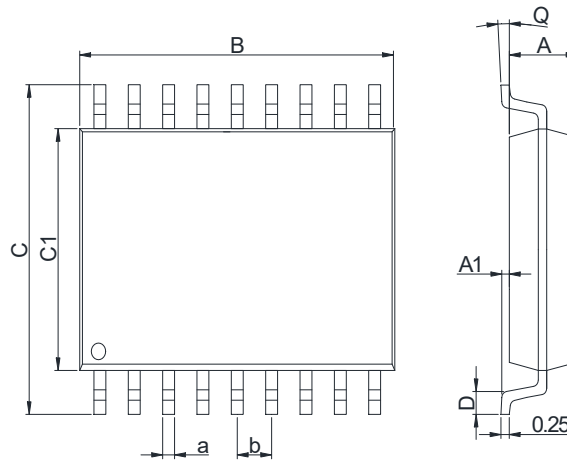

Dimensions In Millimeters(SOP18L)									
Symbol:	A	A1	B	C	C1	D	Q	a	b
Min:	2.10	0.08	11.25	10.10	7.30	0.7	0°	0.35	1.27 BSC
Max:	2.50	0.28	11.65	10.50	7.70	1	8°	0.44	

DIP18

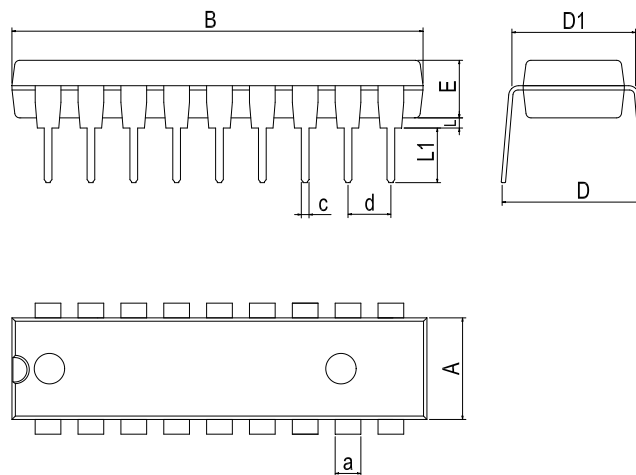

Dimensions In Millimeters(DIP18)										
Symbol:	A	B	D	D1	E	L	L1	a	c	d
Min:	6.10	22.24	8.40	7.42	3.10	0.50	3.00	1.50	0.40	2.54 BSC
Max:	6.68	23.24	9.00	7.82	3.55	0.70	3.60	1.55	0.50	

IMPORTANT STATEMENT:

Huaguan Semiconductor reserves the right to change its products and services without notice. Before ordering, the customer shall obtain the latest relevant information and verify whether the information is up to date and complete. Huaguan Semiconductor does not assume any responsibility or obligation for the altered documents.

Customers are responsible for complying with safety standards and taking safety measures when using Huaguan Semiconductor products for system design and machine manufacturing. You will bear all the following responsibilities: select the appropriate Huaguan Semiconductor products for your application; Design, validate and test your application; Ensure that your application meets the appropriate standards and any other safety, security or other requirements. To avoid the occurrence of potential risks that may lead to personal injury or property loss.

Huaguan Semiconductor products have not been approved for applications in life support, military, aerospace and other fields, and Huaguan Semiconductor will not bear the consequences caused by the application of products in these fields.

The technical and reliability data (including data sheets), design resources (including reference designs), application or other design suggestions, network tools, safety information and other resources provided for the performance of semiconductor products produced by Huaguan Semiconductor are not guaranteed to be free from defects and no warranty, express or implied, is made. The use of testing and other quality control technologies is limited to the quality assurance scope of Huaguan Semiconductor. Not all parameters of each device need to be tested.

The documentation of Huaguan Semiconductor authorizes you to use these resources only for developing the application of the product described in this document. You have no right to use any other Huaguan Semiconductor intellectual property rights or any third party intellectual property rights. It is strictly forbidden to make other copies or displays of these resources. You should fully compensate Huaguan Semiconductor and its agents for any claims, damages, costs, losses and debts caused by the use of these resources. Huaguan Semiconductor accepts no liability for any loss or damage caused by infringement.

X-ON Electronics

Largest Supplier of Electrical and Electronic Components

Click to view similar products for [Switching Voltage Regulators](#) category:

Click to view products by [HGSEMI](#) manufacturer:

Other Similar products are found below :

[FAN53610AUC33X](#) [FAN53611AUC123X](#) [EN6310QA](#) [160215](#) [R3](#) [KE177614](#) [FAN53611AUC12X](#) [MAX809TTR](#) [AST1S31PUR](#)
[NCP81103MNTXG](#) [NCP81203PMNTXG](#) [NCP81208MNTXG](#) [PCA9412AUKZ](#) [NCP81109GMNTXG](#) [NCP81109JMNTXG](#) [MP2161AGJ-Z](#)
[NCP81241MNTXG](#) [MPQ4481GU-AEC1-P](#) [MP8756GD-P](#) [MPQ2171GJ-P](#) [MPQ2171GJ-AEC1-P](#) [MP2171GJ-P](#) [NCV1077CSTBT3G](#)
[MP28160GC-Z](#) [MPM3509GQVE-AEC1-P](#) [XDPE132G5CG000XUMA1](#) [MP5461GC-P](#) [IR3888AMTRPBFAUMA1](#) [MPQ4409GQBE-AEC1-](#)
[P](#) [S-19903DA-A8T1U7](#) [S-19903CA-A6T8U7](#) [S-19903CA-S8T1U7](#) [S-19902BA-A6T8U7](#) [S-19902CA-A6T8U7](#) [AP7361EA-SPR-13](#)
[AP7361EA-33DR-13](#) [S-19902AA-A6T8U7](#) [S-19903AA-A6T8U7](#) [S-19902AA-S8T1U7](#) [S-19902BA-A8T1U7](#) [AU8310](#) [LMR36503R5RPER](#)
[LMR36503RFRPER](#) [LMR54406DBVR](#) [XC9110C301MR-G](#) [XC9141A50CMR-G](#) [XCL206F083CR-G](#) [XCL210A111GR-G](#)
[LTM4663EV#PBF](#) [LD5537B1GL](#)