

ULN2003/ULN2004 Seven Darlington array

Features

- Seven Darlingtontons per package
- Output current 500 mA per driver (600 mA peak)
- Output voltage 50 V
- Integrated suppression diodes for inductive loads
- Outputs can be paralleled for higher current
- TTL/CMOS/PMOS/DTL compatible inputs
- Inputs pinned opposite outputs to simplify layout

Description

The ULN2003, ULN2004, are high voltage, high current Darlington arrays each containing seven open collector Darlington pairs with common emitters. Each channel rated at 500 mA and can withstand peak currents of 600 mA. Suppression diodes are included for inductive load driving and the inputs are pinned opposite the outputs to simplify board layout.

The versions interface to all common logic families:

- ULN2003 (5 V TTL, CMOS)
- ULN2004 (6 - 15 V CMOS, PMOS)

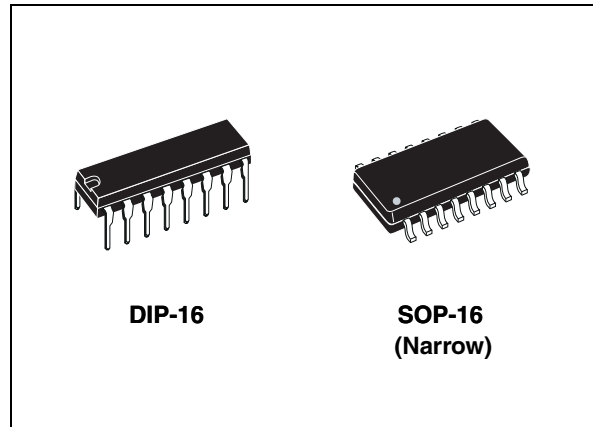

These versatile devices are useful for driving a wide range of loads including solenoids, relays DC motors, LED displays filament lamps, thermal printheads and high power buffers.

The ULN2003A/2004A are supplied in 16 pin plastic DIP packages with a copper leadframe to reduce thermal resistance. They are available also in small outline package (SOP-16) as ULN2003D/2004D

Pin configuration

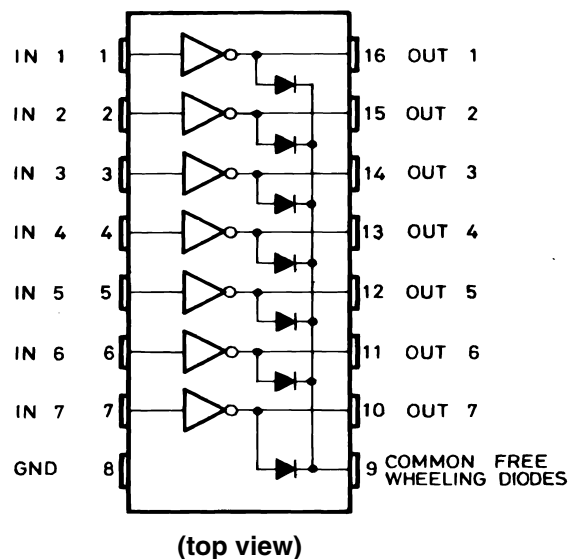

Diagram

Schematic diagram

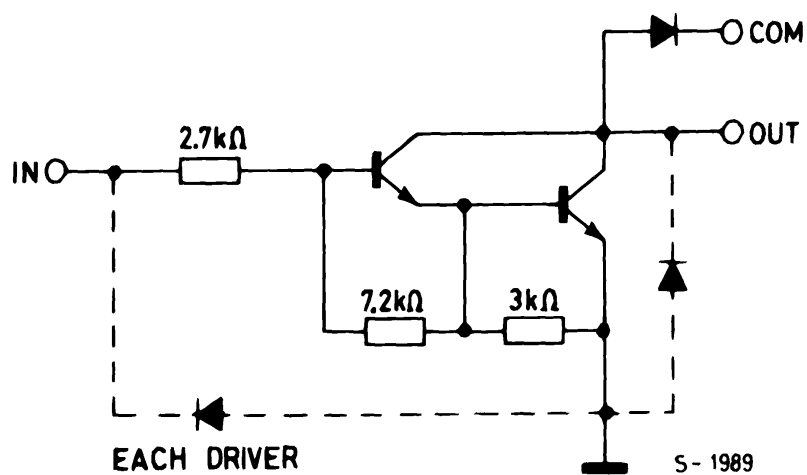

ULN2003 (each driver)

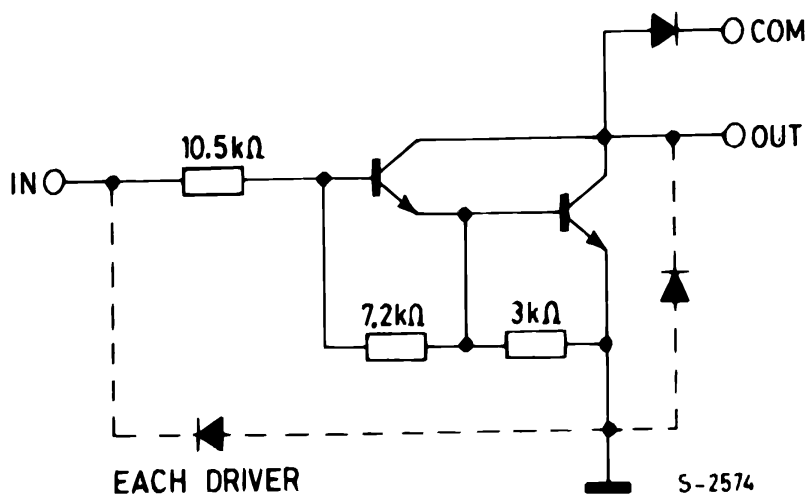

ULN2004 (each driver)

Maximum ratings

Absolute maximum ratings

Symbol	Parameter	Value	Unit
V_O	Output voltage	50	V
V_I	Input voltage (for ULN2003A/D - 2004A/D)	30	V
I_C	Continuous collector current	500	mA
I_B	Continuous base current	25	mA
T_A	Operating ambient temperature range	- 40 to 85	°C
T_{STG}	Storage temperature range	- 55 to 150	°C
T_J	Junction temperature	150	°C

Thermal data

Symbol	Parameter	DIP-16	SO-16	Unit
R_{thJA}	Thermal resistance junction-ambient, Max.	70	120	°C/W

Electrical characteristics

$T_A = 25\text{ }^\circ\text{C}$ unless otherwise specified.

Electrical characteristics

Symbol	Parameter	Test condition	Min.	Typ.	Max.	Unit
I_{CEX}	Output leakage current	$V_{CE} = 50\text{ V}$, (<i>Figure 1.</i>)			50	μA
		$T_A = 85^\circ\text{C}$, $V_{CE} = 50\text{ V}$ (<i>Figure 1.</i>)			100	
		$T_A = 85^\circ\text{C}$ for ULN2002, $V_{CE} = 50\text{ V}$, $V_I = 6\text{ V}$ (<i>Figure 2.</i>)			500	
		$T_A = 85^\circ\text{C}$ for ULN2002, $V_{CE} = 50\text{ V}$, $V_I = 1\text{ V}$ (<i>Figure 2.</i>)			500	
$V_{CE(SAT)}$	Collector-emitter saturation voltage (<i>Figure 3.</i>)	$I_C = 100\text{ mA}$, $I_B = 250\text{ }\mu\text{A}$		0.9	1.1	V
		$I_C = 200\text{ mA}$, $I_B = 350\text{ }\mu\text{A}$		1.1	1.3	
		$I_C = 350\text{ mA}$, $I_B = 500\text{ }\mu\text{A}$		1.3	1.6	
$I_{I(ON)}$	Input current (<i>Figure 4.</i>)	for ULN2002, $V_I = 17\text{ V}$		0.82	1.25	mA
		for ULN2003, $V_I = 3.85\text{ V}$		0.93	1.35	
		for ULN2004, $V_I = 5\text{ V}$		0.35	0.5	
		$V_I = 12\text{ V}$		1	1.45	
$I_{I(OFF)}$	Input current (<i>Figure 5.</i>)	$T_A = 85^\circ\text{C}$, $I_C = 500\text{ }\mu\text{A}$	50	65		μA
$V_{I(ON)}$	Input voltage (<i>Figure 6.</i>)	$V_{CE} = 2\text{ V}$, for ULN2002			13	V
		$I_C = 300\text{ mA}$			2.4	
		for ULN2003			2.7	
		$I_C = 200\text{ mA}$			3	
		$I_C = 250\text{ mA}$			5	
		$I_C = 300\text{ mA}$			6	
		for ULN2004			7	
		$I_C = 125\text{ mA}$			8	
$I_C = 200\text{ mA}$						
$I_C = 275\text{ mA}$						
$I_C = 350\text{ mA}$						
h_{FE}	DC Forward current gain (<i>Figure 3.</i>)	for ULN2001, $V_{CE} = 2\text{ V}$, $I_C = 350\text{ mA}$	1000			
C_I	Input capacitance			15	25	pF
t_{PLH}	Turn-on delay time	$0.5 V_I$ to $0.5 V_O$		0.25	1	μs
t_{PHL}	Turn-off delay time	$0.5 V_I$ to $0.5 V_O$		0.25	1	μs
I_R	Clamp diode leakage current (<i>Figure 7.</i>)	$V_R = 50\text{ V}$			50	μA
		$T_A = 85^\circ\text{C}$, $V_R = 50\text{ V}$			100	
V_F	Clamp diode forward voltage (<i>Figure 8.</i>)	$I_F = 350\text{ mA}$		1.7	2	V

Test circuits

Figure 1. Output leakage currentFigure

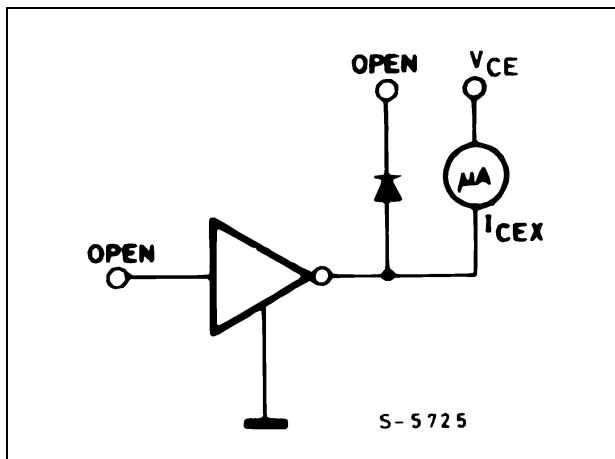

Figure 2. Output leakage current

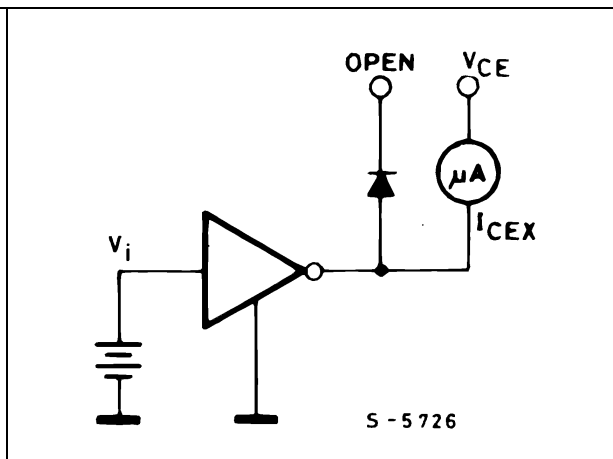

Figure 3. Collector-emitter saturation voltage

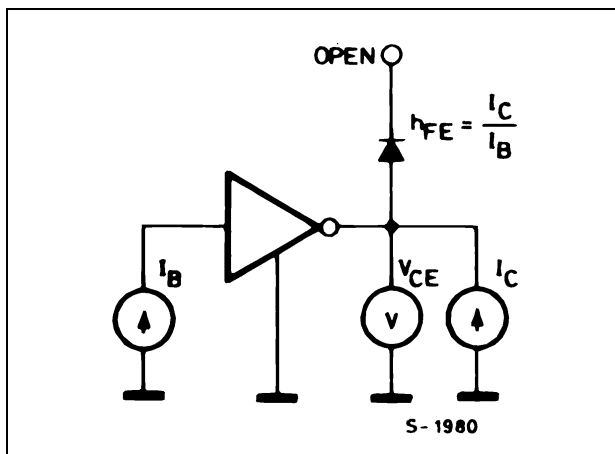

Figure 4. Input current (ON)

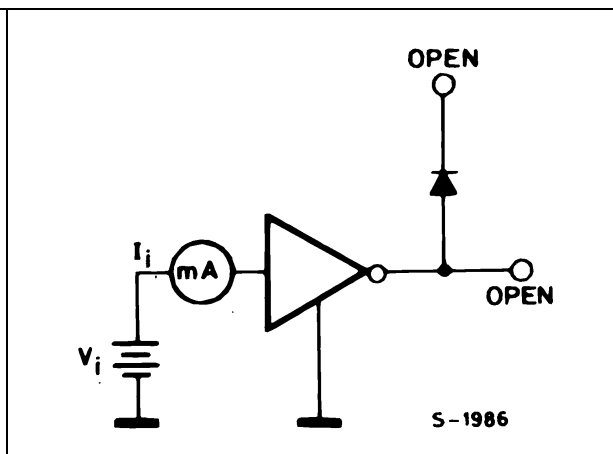

Figure 5. Input current (OFF)

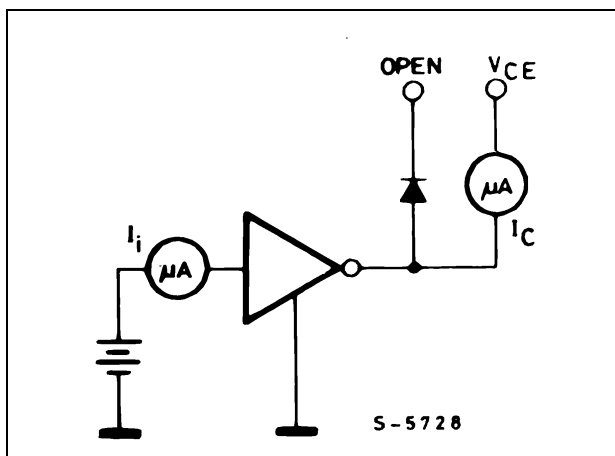

Figure 6. Input voltage

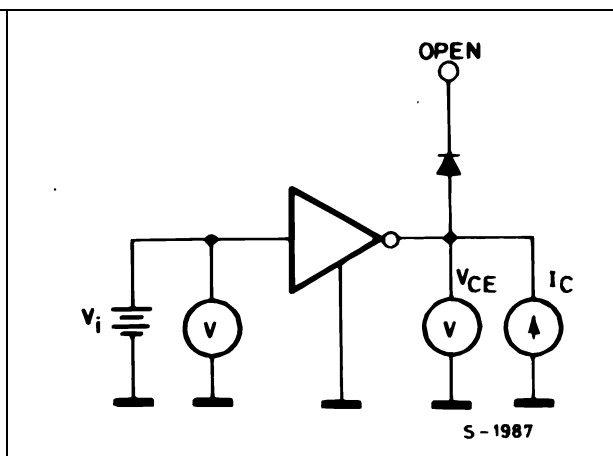

Figure 7. Clamp diode leakage current

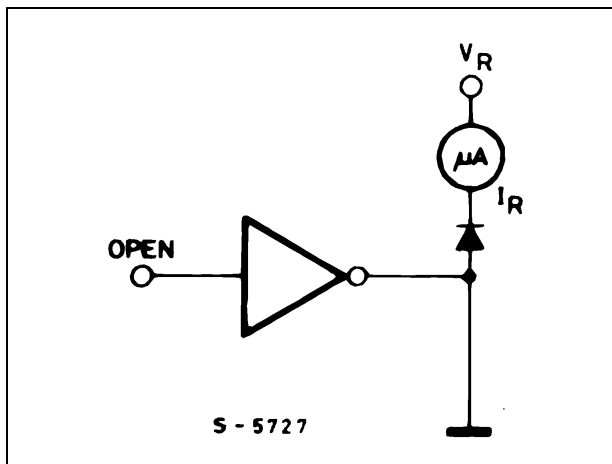
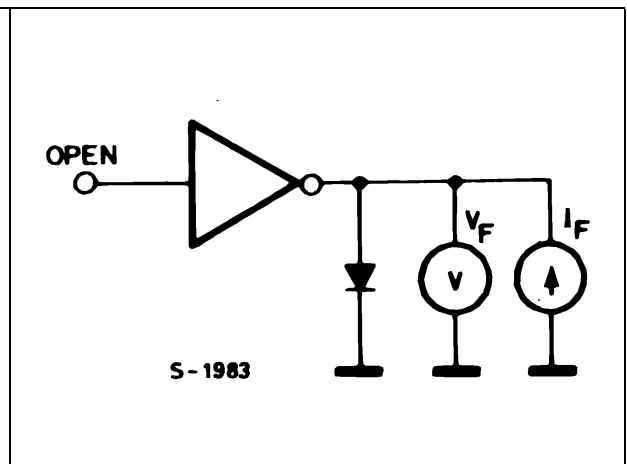

Figure 8. Clamp diode forward voltage



Typical performance characteristics

Figure 9. Collector current vs. saturation voltage ($T_J = 25^\circ\text{C}$)

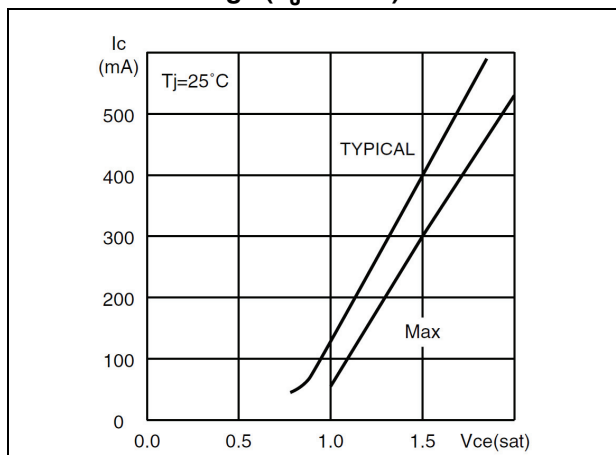

Figure 10. Collector current vs. saturation voltage

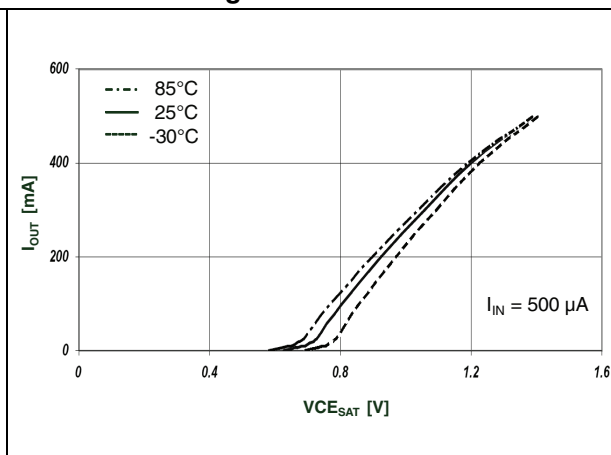

Figure 11. Input current vs. input voltage

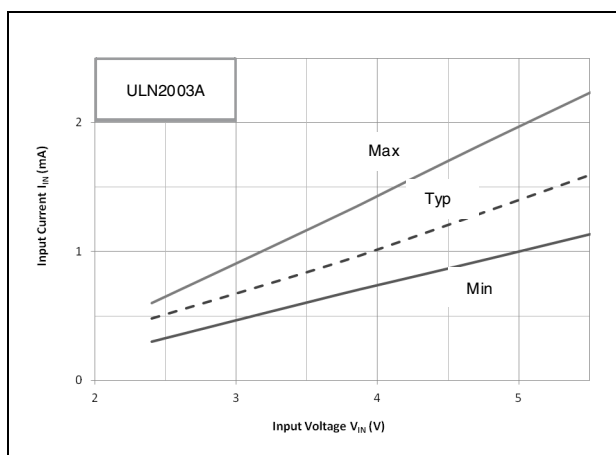

Figure 12. Input current vs. input voltage ($T_a = 25^\circ\text{C}$)

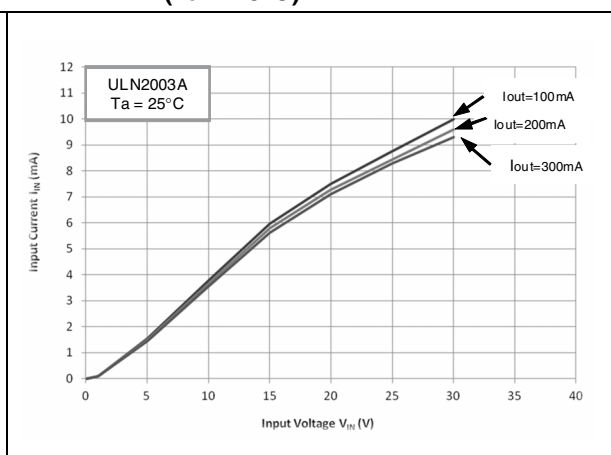

Figure 13. Collector current vs. input current

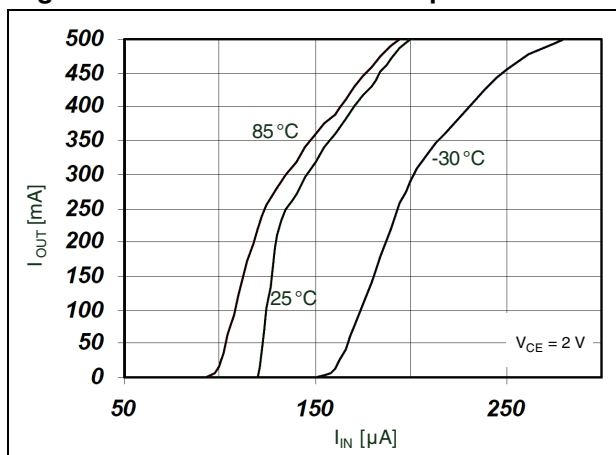

Figure 14. h_{FE} vs. output current

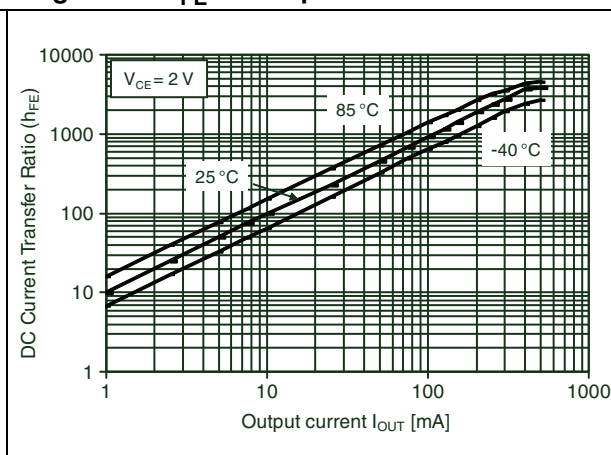

Figure 15. Peak collector current vs. duty cycle (DIP-16)

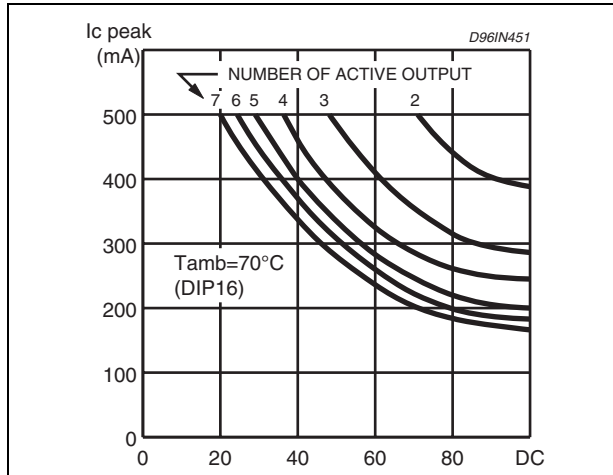
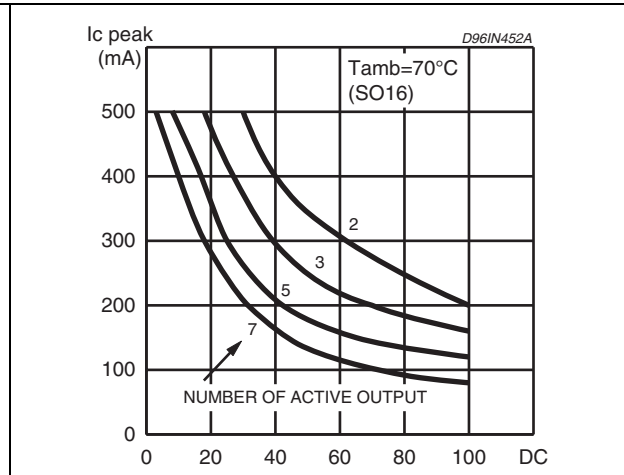

Figure 16. Peak collector current vs. duty cycle (SO-16)



Important statement:

Huaguan Semiconductor Co,Ltd. reserves the right to change the products and services provided without notice. Customers should obtain the latest relevant information before ordering, and verify the timeliness and accuracy of this information.

Customers are responsible for complying with safety standards and taking safety measures when using our products for system design and machine manufacturing to avoid potential risks that may result in personal injury or property damage.

Our products are not licensed for applications in life support, military, aerospace, etc., so we do not bear the consequences of the application of these products in these fields.

Our documentation is only permitted to be copied without any tampering with the content, so we do not accept any responsibility or liability for the altered documents.

X-ON Electronics

Largest Supplier of Electrical and Electronic Components

Click to view similar products for [Darlington Transistors](#) category:

Click to view products by [HGSEMI](#) manufacturer:

Other Similar products are found below :

[BDV64B](#) [SBSP52T1G](#) [Jantx2N6058](#) [LB1205-L-E](#) [2N6053](#) [MPSA63](#) [2N6667](#) [NTE256](#) [TIP120](#) [MJ11028](#) [TIP127](#) [Jantx2N6352](#)
[NJVBUB323ZT4G](#) [ULN2003](#) [ULN2803QN](#) [GN2003B](#) [MJD127T4G-JSM](#) [KID65004AF-EL/P](#) [ULN2803](#) [ULN2803CDWR](#) [HT62783ARTZ](#)
[ULN2803A](#) [GN2803A](#) [MC1413BM/TR](#) [ULN2003AN](#) [ULN2003LVM/TR](#) [HT1413ARZ](#) [ULN2803A](#) [ULN2003](#) [ULN2803](#) [IK62783N](#)
[IK62083N](#) [ULN2003AL](#) [MMBTA63](#) [ULN2001D](#) [2SB1560](#) [2SB852KT146B](#) [2SD2560](#) [TIP112TU](#) [BCV27](#) [MMBTA13-TP](#) [MMBTA14-TP](#)
[MMSTA28T146](#) [BSP50H6327XTSA1](#) [NTE2557](#) [NJVNJD35N04T4G](#) [MPSA29-D26Z](#) [MJD127T4](#) [FMMT38C](#) [BCV26E6327HTSA1](#)