

SOT-23 Plastic-Encapsulate Transistors

TRANSISTOR(PNP)

Features

- Complementary to S9014

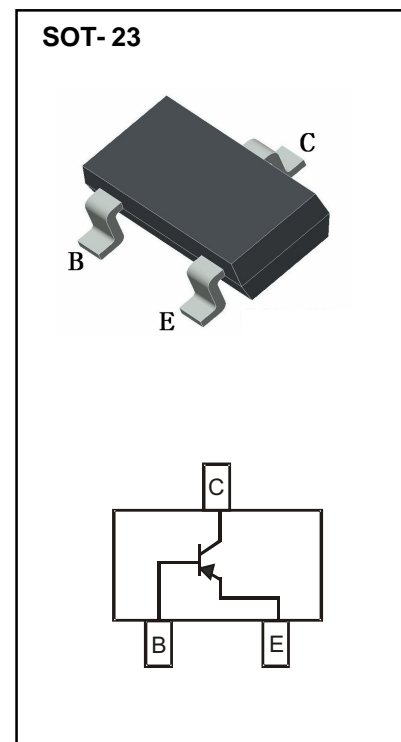

Limiting Values (Absolute Maximum Rating)

| Symbol | Parameter | Value | Unit |
|-----------------|---|----------|---------------|
| V_{CB0} | Collector-Base Voltage | -50 | V |
| V_{CEO} | Collector-Emitter Voltage | -45 | V |
| V_{EBO} | Emitter-Base Voltage | -5 | V |
| I_C | Collector Current | -100 | mA |
| P_C | Collector Power Dissipation | 200 | mW |
| $R_{\theta JA}$ | Thermal Resistance From Junction To Ambient | 625 | $^{\circ}C/W$ |
| T_j | Junction Temperature | 150 | $^{\circ}C$ |
| T_{stg} | Storage Temperature | -55~+150 | $^{\circ}C$ |

Electrical Characteristics (Ta=25 $^{\circ}C$ Unless otherwise specified)

| Parameter | Symbol | Test conditions | Min | Typ | Max | Unit |
|--------------------------------------|---------------|--|-----|-----|------|---------|
| Collector-base breakdown voltage | $V_{(BR)CBO}$ | $I_C = -100\mu A, I_E = 0$ | -50 | | | V |
| Collector-emitter breakdown voltage | $V_{(BR)CEO}$ | $I_C = -0.1mA, I_B = 0$ | -45 | | | V |
| Emitter-base breakdown voltage | $V_{(BR)EBO}$ | $I_E = -100\mu A, I_C = 0$ | -5 | | | V |
| Collector cut-off current | I_{CBO} | $V_{CB} = -50V, I_E = 0$ | | | -0.1 | μA |
| Emitter cut-off current | I_{EBO} | $V_{EB} = -5V, I_C = 0$ | | | -0.1 | μA |
| DC current gain | h_{FE} | $V_{CE} = -5V, I_C = -1mA$ | 200 | | 1000 | |
| Collector-emitter saturation voltage | $V_{CE(sat)}$ | $I_C = -100mA, I_B = -10mA$ | | | -0.3 | V |
| Base-emitter saturation voltage | $V_{BE(sat)}$ | $I_C = -100mA, I_B = -10mA$ | | | -1 | V |
| Transition frequency | f_T | $V_{CE} = -5V, I_C = -10mA$ $f = 30MHz$ | 150 | | | MHz |

CLASSIFICATION OF h_{FE}

| Rank | L | H |
|---------|---------|----------|
| Range | 200-450 | 450-1000 |
| Marking | M6 | M7 |

Typical Characteristics

Static Characteristic

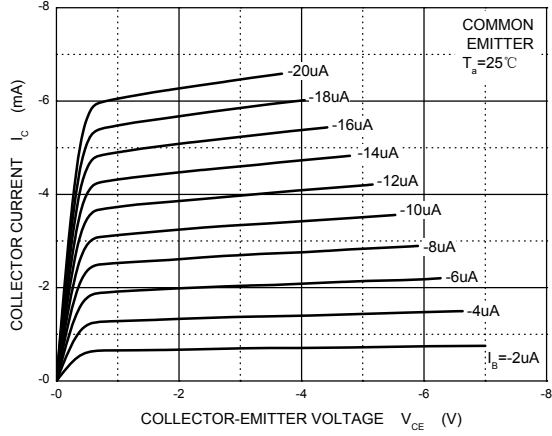

h_{FE} — I_c

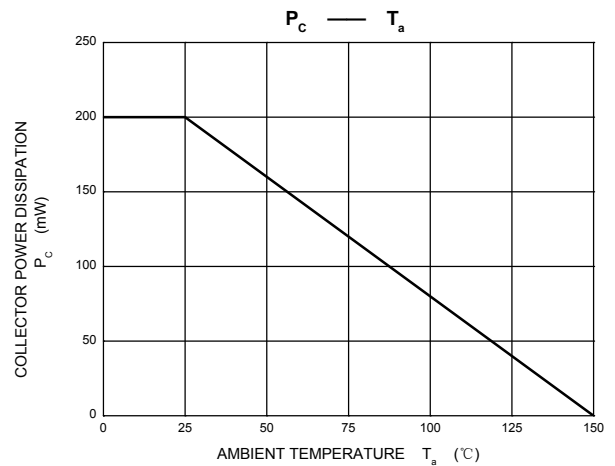
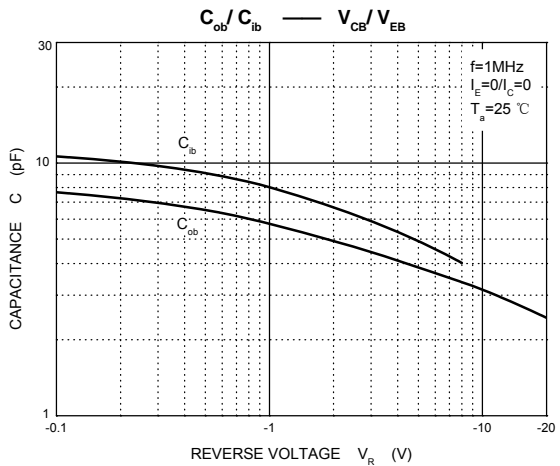
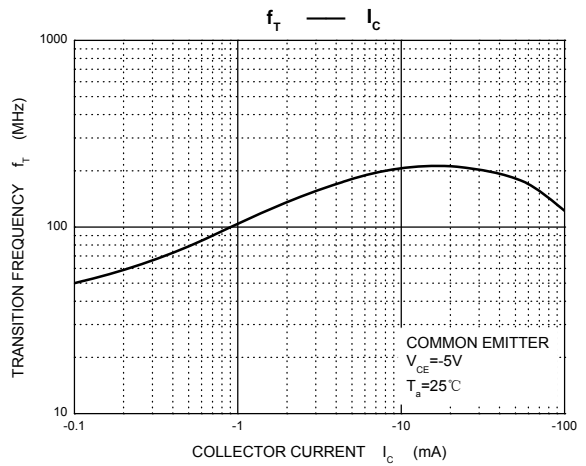
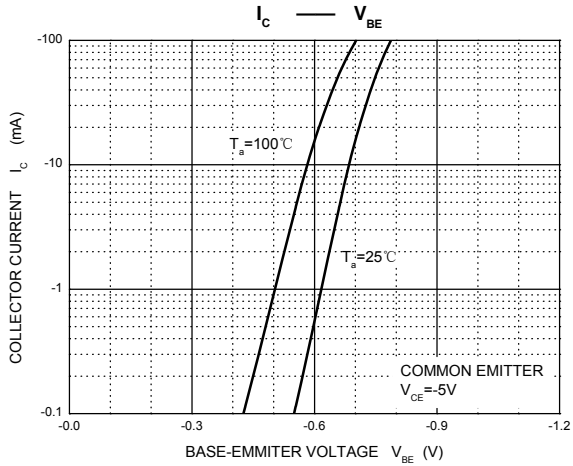
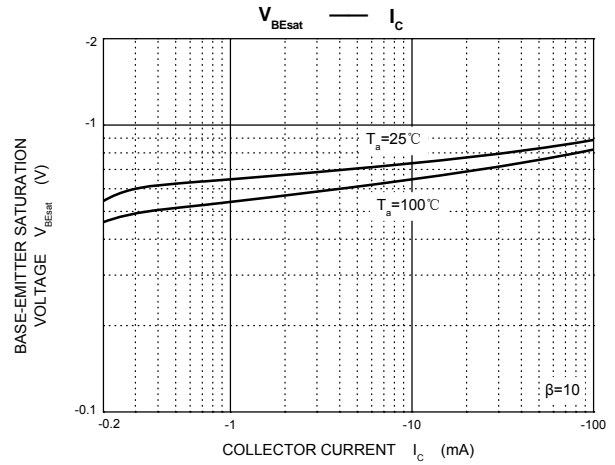
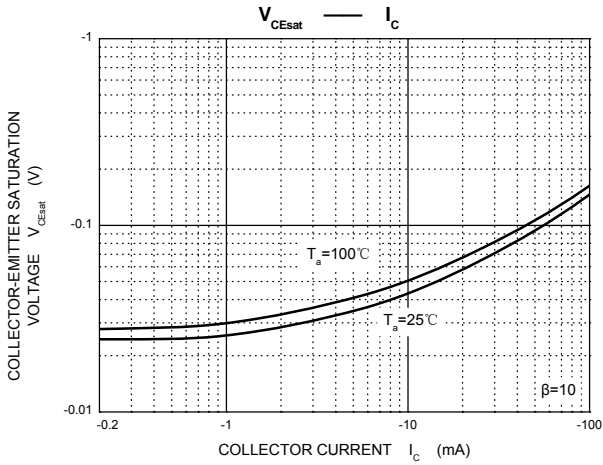
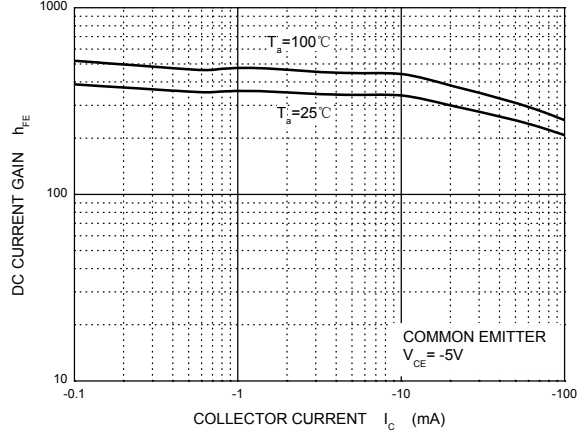

SOT-23 Package Outline Dimensions

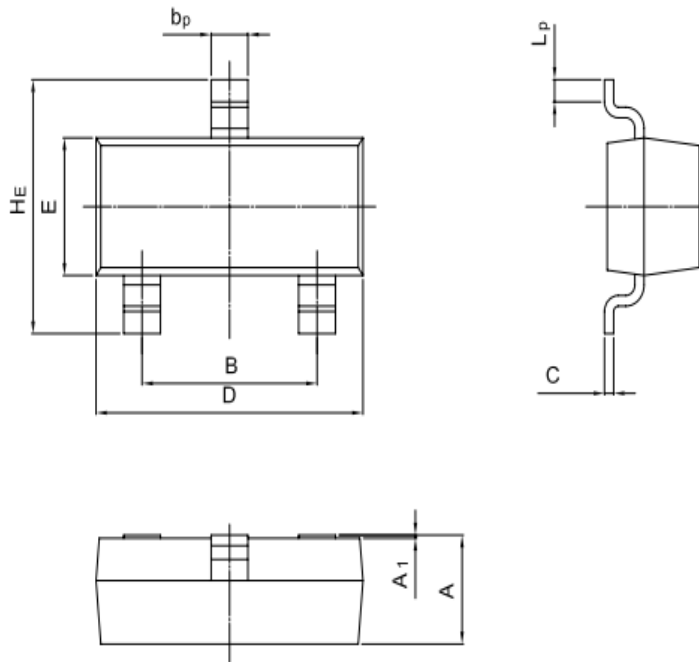

| UNIT | A | B | bp | C | D | E | HE | A1 | Lp |
|------|--------------|--------------|--------------|--------------|--------------|--------------|--------------|----------------|--------------|
| mm | 1.40 0.95 | 2.04 1.78 | 0.50 0.35 | 0.19 0.08 | 3.10 2.70 | 1.65 1.20 | 3.00 2.20 | 0.100 0.013 | 0.50 0.20 |

SOT-23 Suggested Pad Layout

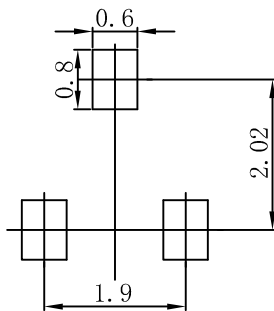

Note:

1. Controlling dimension: in millimeters.
2. General tolerance: $\pm 0.05\text{mm}$.
3. The pad layout is for reference purposes only.

NOTICE

JSHD reserve the right to make modifications, enhancements, improvements, corrections or other changes without further notice to any product herein. JSHD does not assume any liability arising out of the application or use of any product described herein.

Reel Taping Specifications For Surface Mount Devices-SOT-23

SOT-23 Embossed Carrier Tape

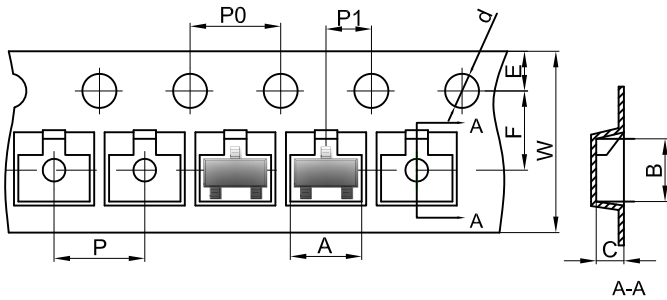

Packaging Description:

SOT-23 parts are shipped in tape. The carrier tape is made from a dissipative (carbon filled) polycarbonate resin. The cover tape is a multilayer film (Heat Activated Adhesive in nature) primarily composed of polyester film, adhesive layer, sealant, and anti-static sprayed agent. These reeled parts in standard option are shipped with 3,000 units per 7" or 17.8cm diameter reel. The reels are clear in color and is made of polystyrene plastic (anti-static coated).

Dimensions are in millimeter

| Pkg type | A | B | C | d | E | F | P0 | P | P1 | W |
|----------|------|------|------|-------|------|------|------|------|------|------|
| SOT-23 | 3.15 | 2.77 | 1.22 | Ø1.50 | 1.75 | 3.50 | 4.00 | 4.00 | 2.00 | 8.00 |

SOT-23 Tape Leader and Trailer

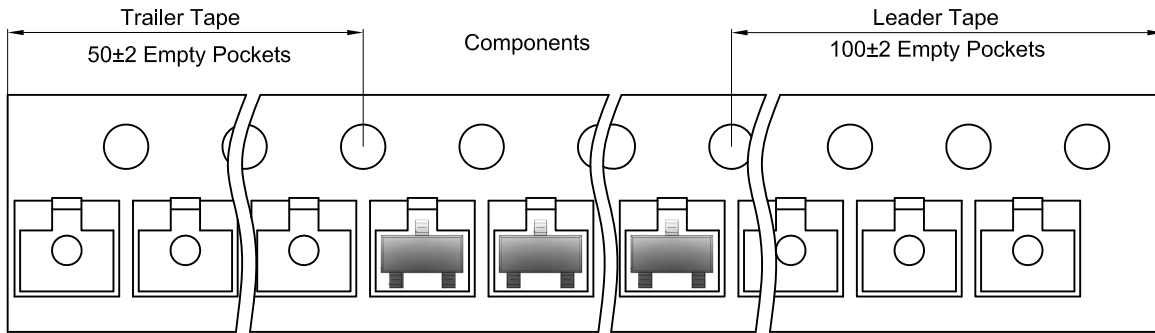

SOT-23 Reel

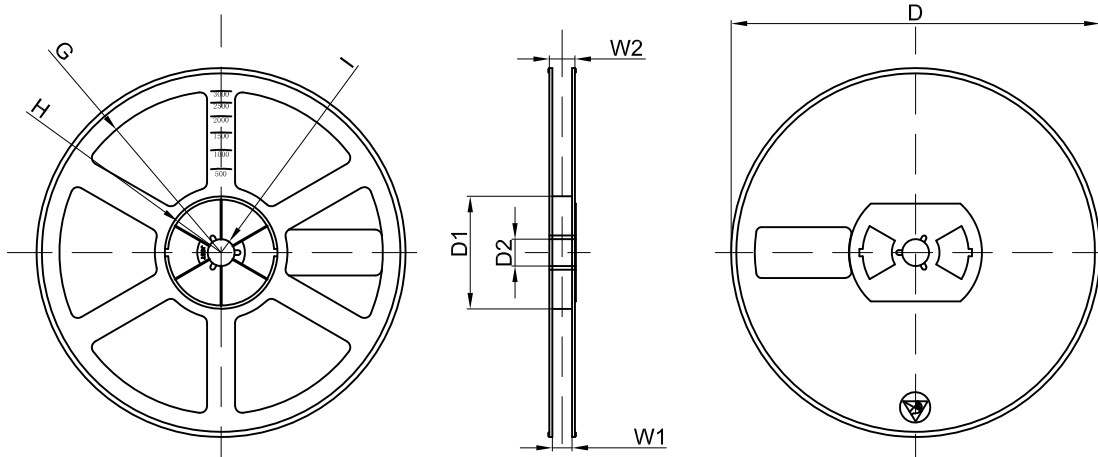

Dimensions are in millimeter

| Reel Option | D | D1 | D2 | G | H | I | W1 | W2 |
|-------------|---------|-------|-------|--------|--------|-------|------|-------|
| 7"Dia | Ø178.00 | 54.40 | 13.00 | R78.00 | R25.60 | R6.50 | 9.50 | 12.30 |

| REEL | Reel Size | Box | Box Size(mm) | Carton | Carton Size(mm) | G.W.(kg) |
|----------|-----------|------------|--------------|-------------|-----------------|----------|
| 3000 pcs | 7 inch | 45,000 pcs | 203×203×195 | 180,000 pcs | 438×438×230 | |

X-ON Electronics

Largest Supplier of Electrical and Electronic Components

Click to view similar products for [Bipolar Transistors - BJT category](#):

Click to view products by [High Diode manufacturer](#):

Other Similar products are found below :

[619691C](#) [MCH4017-TL-H](#) [MJ15024/WS](#) [MJ15025/WS](#) [BC546/116](#) [BC556/FSC](#) [BC557/116](#) [BSW67A](#) [HN7G01FU-A\(T5L,F,T](#)
[NJVMJD148T4G](#) [NSVMMBT6520LT1G](#) [NTE187A](#) [NTE195A](#) [NTE2302](#) [NTE2330](#) [NTE2353](#) [NTE316](#) [IMX9T110](#) [NTE63](#) [NTE65](#)
[C4460](#) [SBC846BLT3G](#) [2SA1419T-TD-H](#) [2SA1721-O\(TE85L,F\)](#) [2SA1727TLP](#) [2SA2126-E](#) [2SB1202T-TL-E](#) [2SB1204S-TL-E](#) [2SC5488A-](#)
[TL-H](#) [2SD2150T100R](#) [SP000011176](#) [FMC5AT148](#) [2N2369ADCSM](#) [2SB1202S-TL-E](#) [2SC2412KT146S](#) [2SC4618TLN](#) [2SC5490A-TL-H](#)
[2SD1816S-TL-E](#) [2SD1816T-TL-E](#) [CMXT2207 TR](#) [CPH6501-TL-E](#) [MCH4021-TL-E](#) [BC557B](#) [TTC012\(Q\)](#) [BULD128DT4](#) [JANTX2N3810](#)
[Jantx2N5416](#) [US6T6TR](#) [KSF350](#) [068071B](#)