

HRS® 3500 Series

Long-Life I/O Connectors

OVERVIEW

These miniature, shielded interface connectors were designed for use with portable terminal equipment. They are suited to a wide range of applications including hand-held terminals and PDA equipment because of excellent insertion/removal durability (20,000 times).

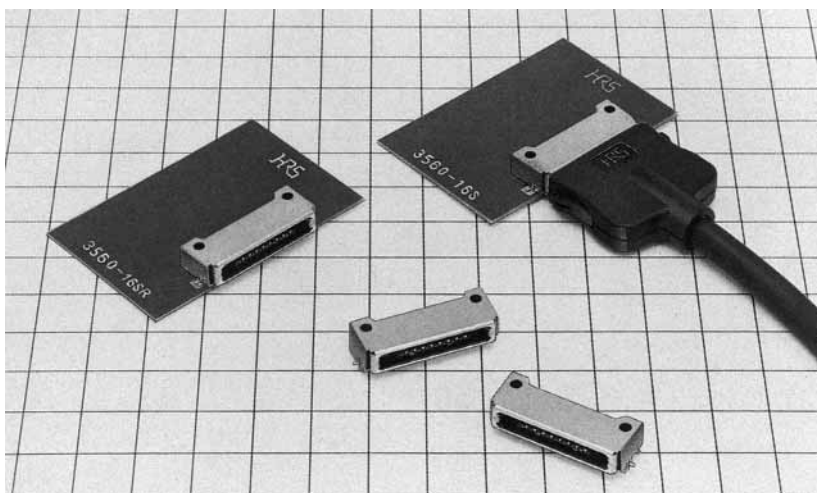

FEATURES

- (1) Long-life connectors have an insertion/removal life of 20,000 cycles.
- (2) The structure of the contacts is the highly reliable, two-contact bellows type.
- (3) The lock uses a snap-lock system which relieves the stress that accompanies forceful removal, making these connectors resistant to external forces such as sudden pulls of the cable.
- (4) Release of the lock is achieved with a simple operation of the push buttons at the left and right sides of the plug. A positive lock sensation is provided by a click locking sound when the connector engages.
- (5) The miniature, lightweight design (i.e., about 2g for a 16-conductor receptacle) makes these connectors effective in reducing the overall size and weight of terminal equipment.
- (6) Use of a new box-bending structure for the metal shell supports EMI protection and makes this a tough connector.
- (7) ESD protection is provided by the metal shell-not the cover (unless it is metal plated).
- (8) The board mounting system uses 0.8-mm spaced single row SMT for easy mounting.
- (9) Suitable boards can be from 0.8 to 1.6mm thick, affording a wide selection of board thicknesses.
- (10) There are two types of plug-side wiring systems, the pressure welding type designed to save labor in wiring, and the solder type which enables an arbitrary selection of the type of cable.

APPLICATIONS

Hand-held terminals, PDA equipment, notebook computers, mobile communications equipment, office automation equipment, measuring instruments, etc.

Major Specifications

Item	Rated Value
Operating temperature range	-40°C to +85°C
Rated voltage	125VAC
Rated current	1A
Insulation resistance	1,000MΩ or greater/ 250VDC
Withstand voltage	350VAC for 1 minute
Contact resistance	40mΩ or less
Insertion/removal life	20,000 times

Materials and Processing

Item		Material	Processing
Receptacles	Insulation	Synthetic resin	Black color UL94V-0
	Contacts	Copper alloy	Selective gold plating
	Shell	Stainless steel	Tin plating
Plugs	Insulation	Synthetic resin	Black color UL94V-0
	Contacts	Copper alloy	Selective gold plating
	Shell	Stainless steel	—
	Lock spring	Stainless steel	—
	Cover	Synthetic resin	Black color

Structure of the Product Number

● Receptacle Connectors

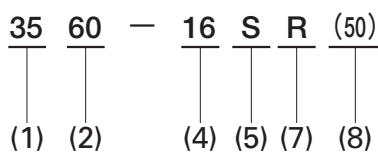

● Plug Connectors

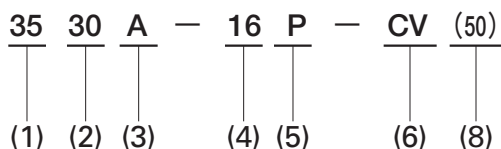

- (1) Series No.: 35
- (2) Termination style
 60: Right-angle SMT type
 30: Discrete wire pressure welding type
 40: Solder type
- (3) Suitable wire
 A: AWG 28
- (4) Number of contacts
- (5) Type of opening portion
 P: Plug connector
 S: Receptacle connector
- (6) Cover form
 CV: Standard type
- (7) Engagement direction of the connector
 No symbol: Forward engagement
 R: Reverse engagement
- (8) Specification contents
 (50): Specifications support RoHS

Diagram of Connector When Engaged

(Please see information about the connector mounting method.)

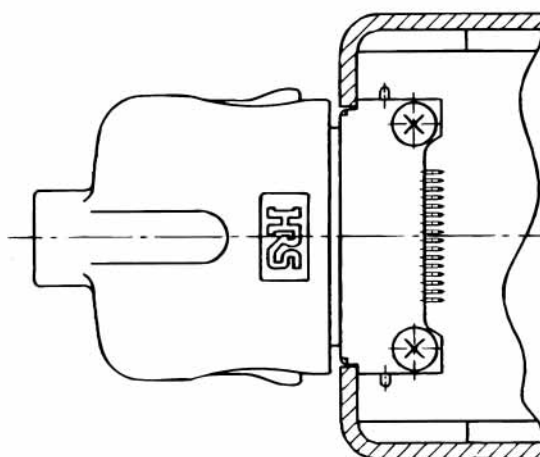
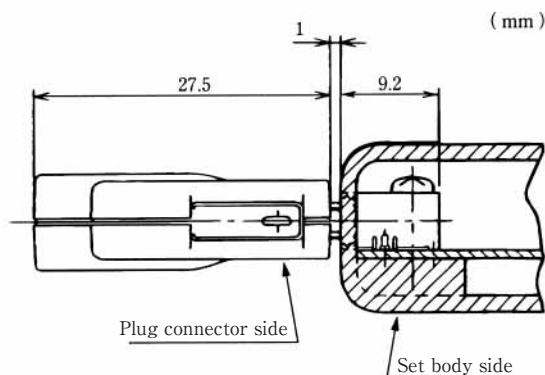

RECEPTACLE CONNECTORS FORWARD ENGAGEMENT TYPE



Forward engagement type
3560-16S (50)

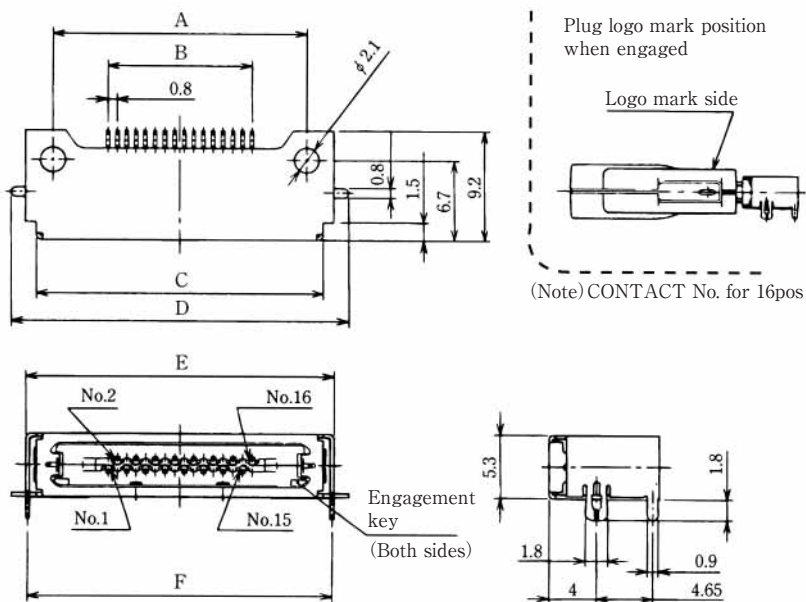

HRS No.	Number of contact	Product No.	A	B	C	D	E	F	RoHS
CL235-0007-0-50	10	3560-10S (50)	16.2	7.2	19	23.2	20.8	20.5	YES
CL235-0001-3-50	16	3560-16S (50)	21	12	23.8	28	25.6	25.3	

Unit: mm

REVERSE ENGAGEMENT TYPE



Reverse engagement type
3560-16SR (50)

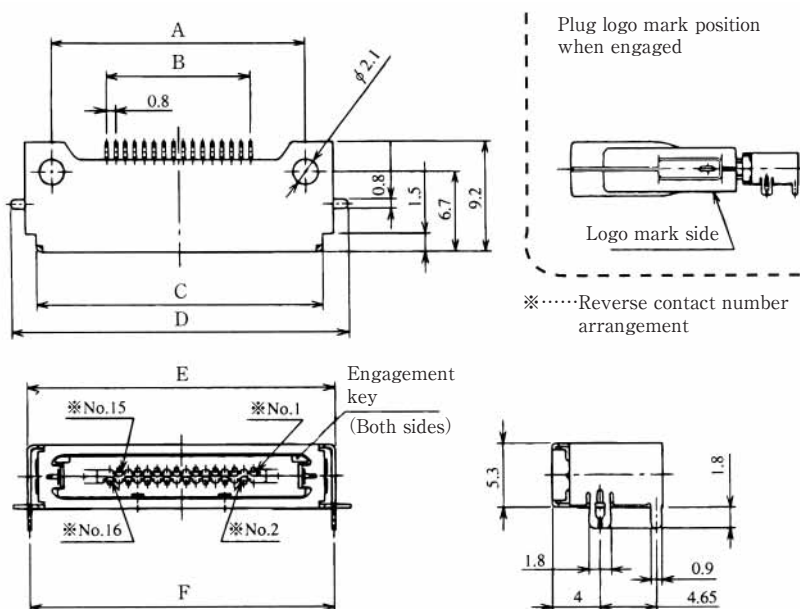

HRS No.	Number of contact	Product No.	A	B	C	D	E	F	RoHS
CL235-0008-2-50	10	3560-10SR (50)	16.2	7.2	19	23.2	20.8	20.5	YES
CL235-0002-6-50	16	3560-16SR (50)	21	12	23.8	28	25.6	25.3	

Unit: mm

■ PLUG CONNECTORS



3530A-16P-CV (50)

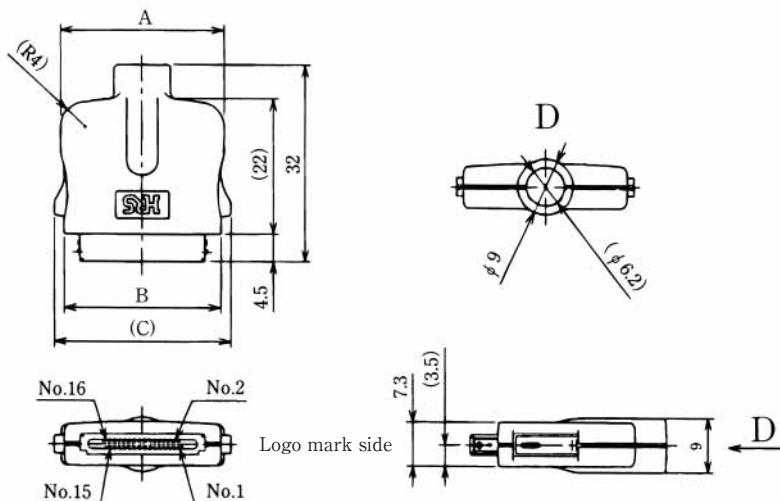

Unit: mm

Item	HRS No.	Number of contact	Product No.	A	B	C	RoHS
Pressure welding wiring type	CL235-0009-5-50	10	3530A-10P-CV (50)	21.8	20.8	24	YES
	CL235-0003-9-50	16	3530A-16P-CV (50)	26.6	25.6	28.8	
Solder wiring type	CL235-0010-4-50	10	3540-10P-CV (50)	21.8	20.8	24	
	CL235-0004-1-50	16	3540-16P-CV (50)	26.6	25.6	28.8	

◆ Internal Structure Diagram (Pressure welding wiring type)

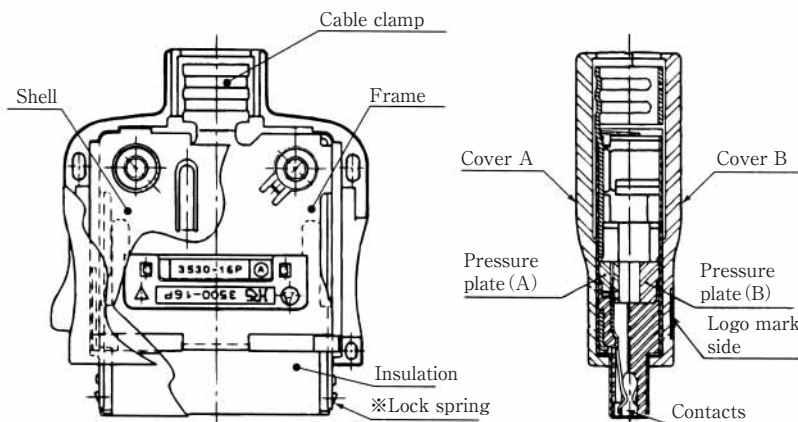

※ This lock spring forms a single body structure with the frame and cable clamp.

Suitable cable	Specification	Number of contact	Cable outside diameter
	AWG28 (7/0.127) UL20276 Conductor outside diameter: ϕ 0.58	10	ϕ 5
		16	ϕ 5.9

◆ Harness tool

Item	Number of contact	Product No.	HRS No.	Tools required for the harness	
				Pressure welding wiring	Solder wiring
Wire forming palette	common	3530/CA-MD	CL902-0345-9	○	—
Set palette	10	3530-10/SP-MP	CL902-2060-0	○	—
	16	3530-16/SP-MP	CL902-2009-2		
Remaining length cutting jig	common	3530/CU-MP	CL902-0346-1	○	—
Pressure welding jig	common	3530/ID-MP	CL902-0347-4	○	—
Cable caulking jig	10	3530-10/CA-MP (01)	CL902-2061-2 (01)	○	○
	16	3530-16/CA-MP (01)	CL902-0348-7 (01)		

Sep.1.2016 Copyright 2016 HIROSE ELECTRIC CO., LTD. All Rights Reserved.

◆ Board Mounting Dimensions Diagram

(Note) CONTACT No. for 16pos.
 No.1 ... (16S)
 No.16(Note) ... (16SR)

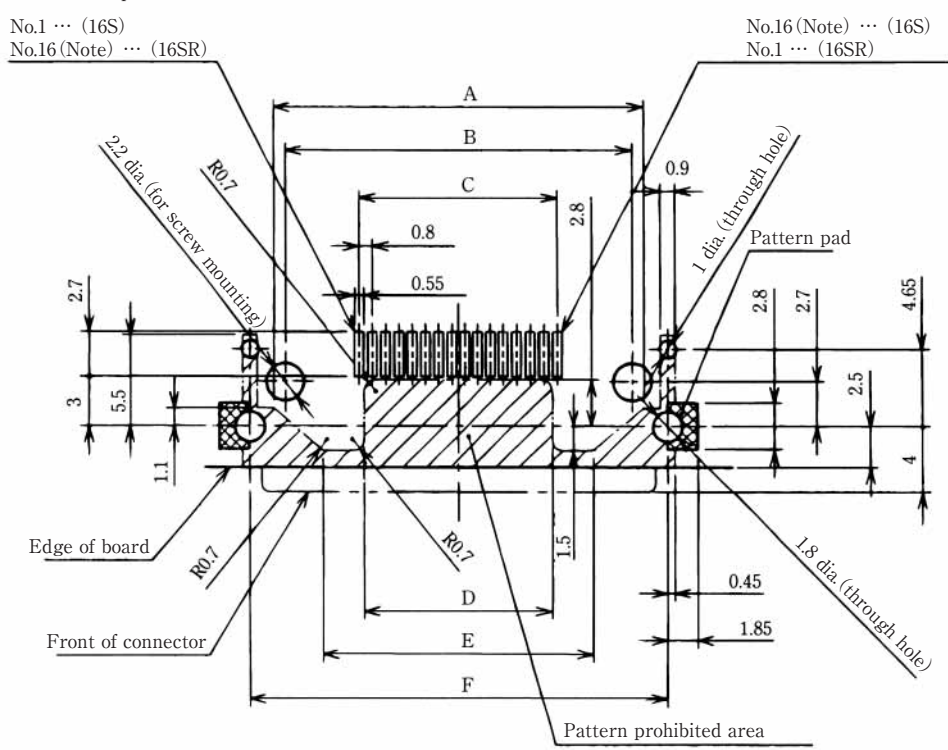

Board mounting dimensions diagram (2 : 1)

Suitable board thickness $t = 0.8 \sim 1.6$

(mm)

Product No.	A	B	C	D	E	F
3560-10S (50)	17.6	16.2	7.2	9.3	11.6	20.5
3560-10SR (50)						
3560-16S (50)	22.4	21	12	11.4	16.4	25.3
3560-16SR (50)						

◆ Technical Document I (Reference)

Number of Insertion / Removal Cycles and Contact Resistance

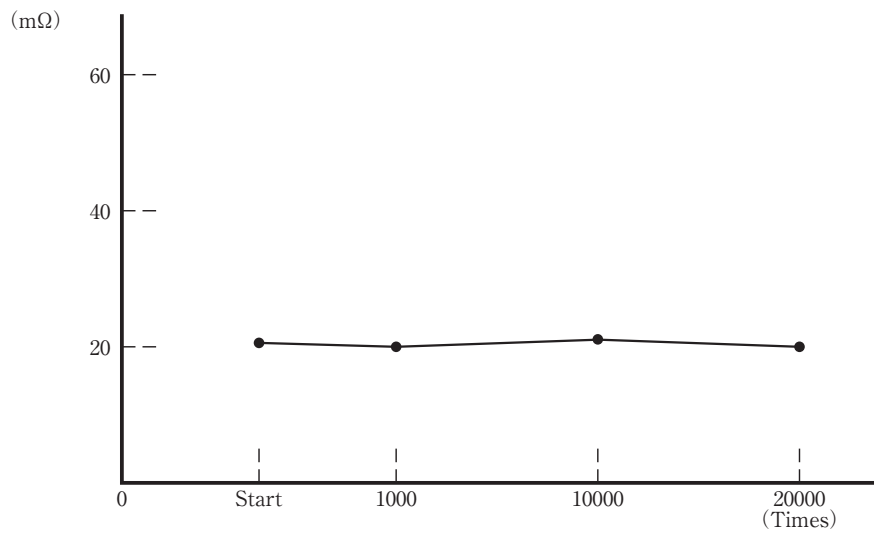

◆ Technical Document II

Connector Mounting Method

1. Soldering Method

This connector and board mounting method uses soldering at the four dip locations marked A at the left and right sides as well as the two surface mounting locations marked B at the left and right sides for a total of six locations.

(Location A represents board through holes of 1.8mm diameter and 1mm diameter, whereas location B represents pads of 2.8×1.85 mm width. (See the board mounting diagram.)

As illustrated in the diagram below, the opening portion of the connector is either inserted into the body of the set or inserted into a rectangular hole of the set.

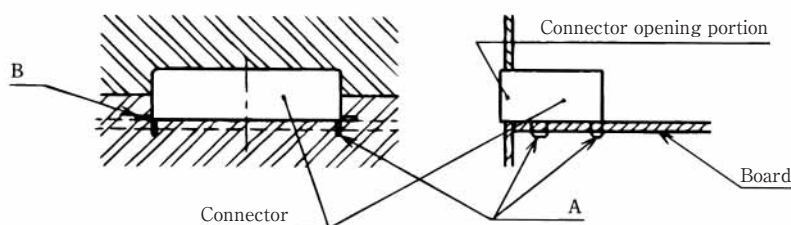

2. Soldering and Screw Fastening Method

When there is not sufficient strength with the connector opening portion at the set, the mounting holes C (as in Figure 1) at the left and right sides of the connector are used after the solder mounting to further fix the connector with M2 screws.

The connector can be fixed to just the board with this method (as in Figure 2); however, in consideration of connector twisting, the most effective mounting method is to fix the connector to both the body and the board with screws as illustrated in Figures 3 and 4.

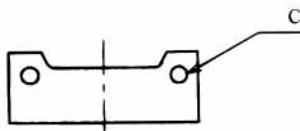

(Figure 1)

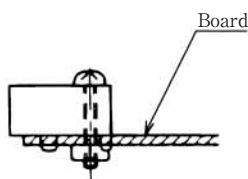

(Figure 2)

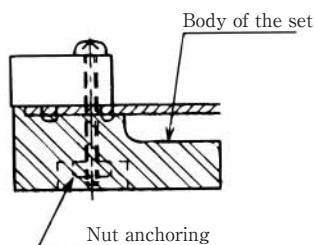

(Figure 3)

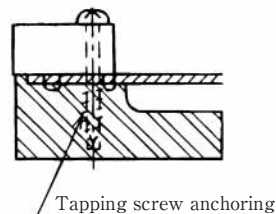

(Figure 4)

X-ON Electronics

Largest Supplier of Electrical and Electronic Components

Click to view similar products for [I/O Connectors](#) category:

Click to view products by [Hirose](#) manufacturer:

Other Similar products are found below :

[571763P](#) [58098-0628](#) [72.250.1628.2](#) [72.250.2428.2](#) [74720-0505](#) [76.350.0729.0](#) [76871-1403](#) [FCN-244F080-G/1](#) [FCN-260A9920](#) [MP-5T180MUNNA-005](#) [PCR-E36PM](#) [PCS-XE26MA+](#) [G38A71314B](#) [1571250010](#) [157-22500-3](#) [MS3471L14-19P L/C](#) [192991-0703](#) [172501-4002](#) [172501-6002](#) [FCN-260C008-A/L0](#) [FCN-260C024-AL0](#) [FCN-261Z008](#) [2000314-1](#) [200331-1](#) [PCR-E36FC+](#) [PCS-E28FS+](#) [PCS-XE26SLFD+](#) [PCS-XE26SLFDT+](#) [G730VID08BDC24](#) [U90B2054081210](#) [UE86K842720321](#) [38113800006](#) [DP3AR020WQ1R200](#) [Z4.102.0680.0](#) [500-1040](#) [500-1052](#) [500-1054](#) [ZP-4008-66L](#) [0709821002](#) [DX40-20P\(55\)](#) [5554841-1](#) [MS3474W18-8P-LC*](#) [SM3106F14S-7S-LC](#) [U90B3054061110](#) [U65-E04-4020](#) [ZPF000000000097891](#) [557-262M2-06C](#) [747360449](#) [10099439-003C-TRLF](#) [10137239-0021LF](#)