

Sep.1.2021 Copyright 2021 HIROSE ELECTRIC CO., LTD. All Rights Reserved.
In case of consideration for using Automotive equipment / device which demand high reliability, kindly contact our sales window correspondents.

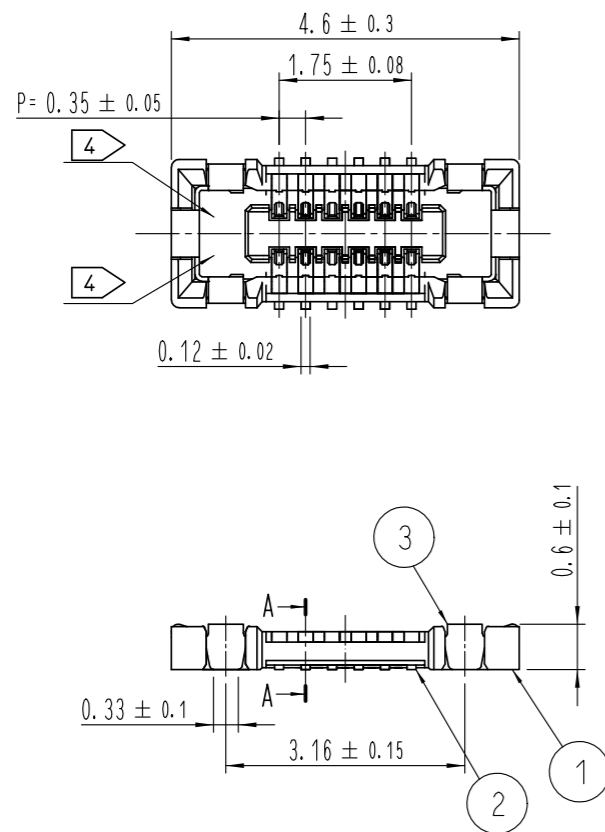

HRS DRAWING FOR REFERENCE

COUNT	DESCRIPTION OF REVISIONS	B	Y	CHKD	DATE	COUNT	DESCRIPTION OF REVISIONS	B	Y	CHKD	DATE
△						△					
△						△					
△						△					

A-A (50:1)

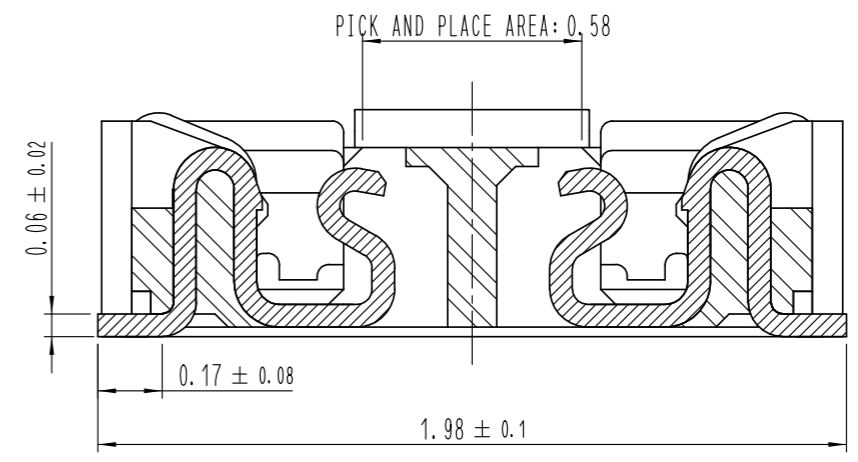

ENGAGEMENT FIGURE (50:1)

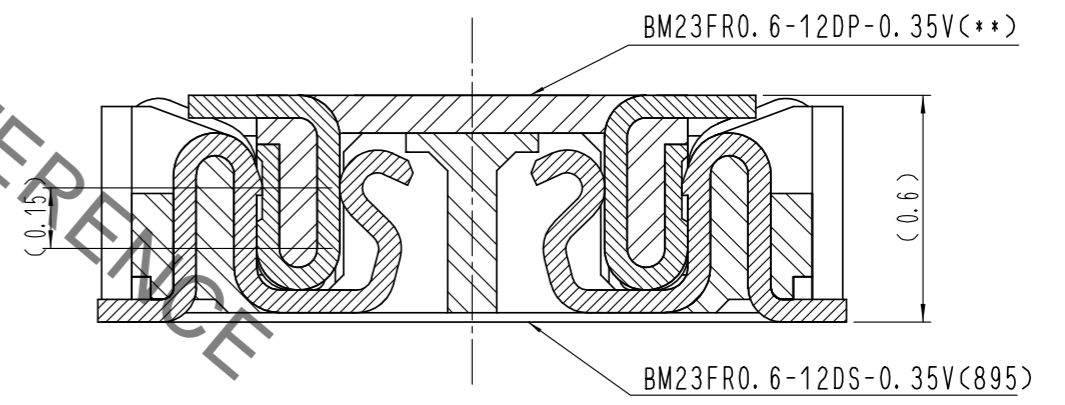

- NOTE
- 1 . ALL LEAD CO-PLANARITY SHALL BE 0.08mm MAX.
 - 2 > CONTACT PLATING SPECIFICATIONS.
CONTACT AREA : GOLD 0.05 μm MIN.
SMT LEAD : GOLD 0.05 μm MIN.
UNDERPLATING : NICKEL 1 μm MIN.
(SURFACE : SEALING)
 - 3 > MATA L FITTING PLATING SPECIFICATIONS.
SMT LEAD : GOLD 0.05 μm MIN.
UNDERPLATING : NICKEL 1 μm MIN.
(SURFACE : SEALING)
 - 4 > HRS MARK AND CAV NO. ARE INDICATED IN APPROX POSITION SHOWN.

4	PS	CLEAR (EMBOSSED CARRIER TAPE)		7	PS	CLEAR (REINFORCEMENT COLLAR)
3	PHOSPHOR BRONZE	3 >		6	PS	BLACK (PLASTIC REEL)
2	PHOSPHOR BRONZE	2 >		5	POLYESTER	CLEAR (COVER TAPE)
1	LCP	UL94 V-0, BLACK				
NO.	MATERIAL	FINISH , REMARKS	NO.	MATERIAL	FINISH , REMARKS	
REMARKS			DRAWN	DESIGNED	CHECKED	APPROVED
			J. S. PARK	J. S. PARK	H. W. JO	T. S. KANG
			17. 08. 09	17. 08. 09	17. 08. 09	17. 08. 09
CODE NO. (OLD)	DRAWING NO. EDC3-632159		PART NO. BM23FR0.6-12DS-0.35V(895)			
SCALE 10:1	UNITS mm		HRS HIROSE KOREA CO., LTD.		CODE NO. CL 6644-0077-9-895	1/3

Sep.1.2021 Copyright 2021 HIROSE ELECTRIC CO., LTD. All Rights Reserved.
In case of consideration for using Automotive equipment / device which demand high reliability, kindly contact our sales window correspondents.

6 RECOMMENDED PCB LAYOUT

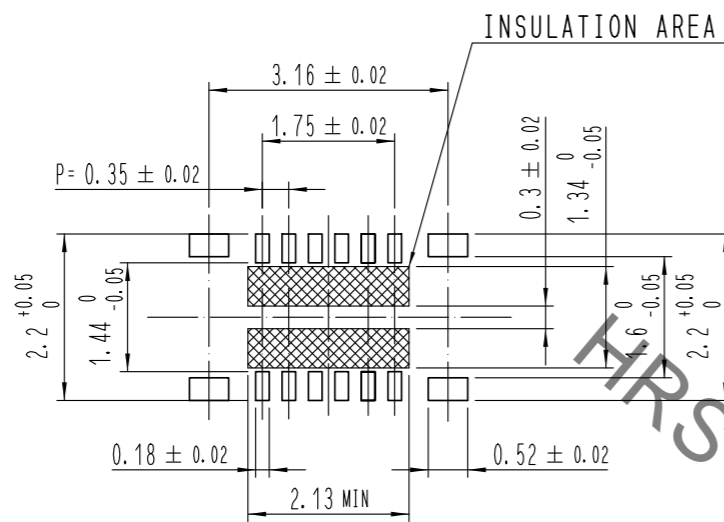

RECOMMENDED METAL MASK DIMENSIONS
MATAL MASK THICKNESS : 100 μm

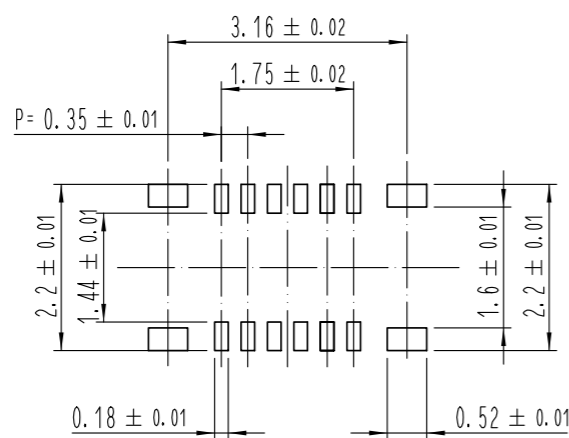

5 RECOMMENDED REFLOW TEMPERATURE PROFILE USING LEAD-FREE SOLDER PASTE.

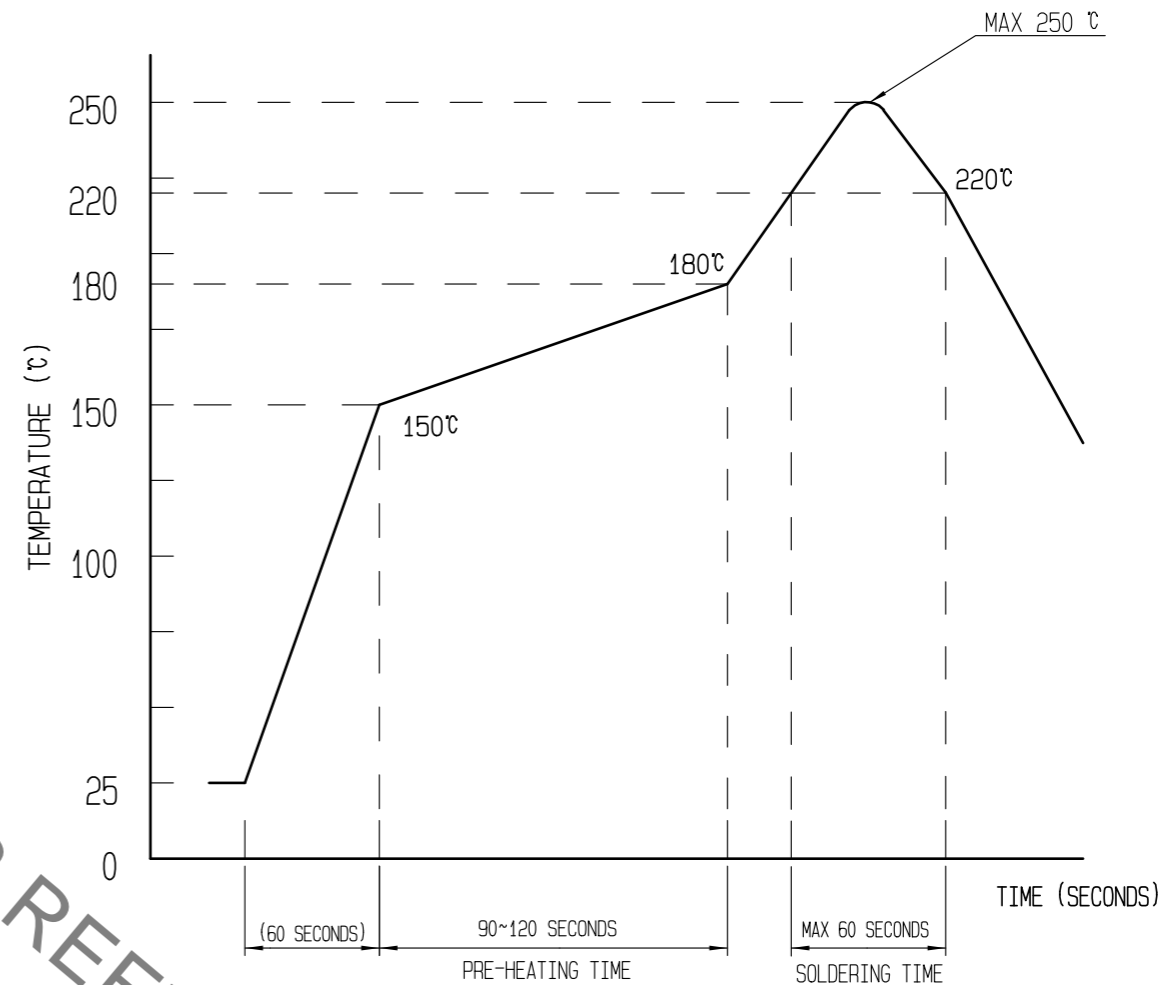

REFLOW METHOD: N₂ REFLOW
NUMBER OF REFLOW CYCLES: 2 CYCLES MAX.
1) REFLOW TIME
DURATION ABOVE 220°C: 60 SEC MAX.
(PEAK TEMPERATURE: 250°C MAX)
2) PRE-HEAT TIME
PRE-HEAT TEMPERATURE(MIN): 150°C
PRE-HEAT TEMPERATURE(MAX): 180°C
PRE-HEAT TIME: 90-120 SEC.

- 5 THIS TEMPERATURE PROFILE IS PER THE CONDITIONS SHOWN ABOVE. ADDITIONAL FACTORS, SUCH AS SOLDER PASTE TYPE, PCB SIZE AND OTHER MOUNTED COMPONENTS COULD AFFECT THE PROFILE. THEREFORE, A THOROUGH EVALUATION OF MOUNTING CONDITION IS REQUIRED PRIOR TO PRODUCTION. TEMPERATURE IS MEASURED AT CONTACT LEAD.
- 6 PLEASE CONTACT US IN CASE YOU WILL MAKE DIFFERENT SETTINGS FROM OUR RECOMMENDATION.

	DRAWING NO.	EDC3-632159	PART NO.	BM23FR0.6-12DS-0.35V(895)	
	SCALE	10:1	CODE NO	CL 6644-0077-9-895	2/3
UNITS	mm		HRS HIROSE KOREA CO., LTD.		

Sep.1.2021 Copyright 2021 HIROSE ELECTRIC CO., LTD. All Rights Reserved.
In case of consideration for using Automotive equipment / device which demand high reliability, kindly contact our sales window correspondents.

STYLE AND DIMENTION OF REEL (FREE)

EMBOSED CARRIER TAPE PACKAGING (5:1)

C-C (5:1)

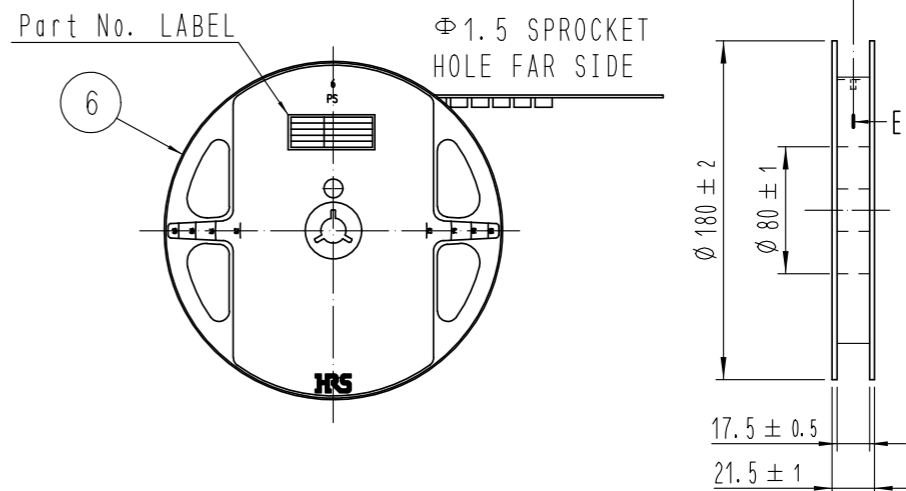
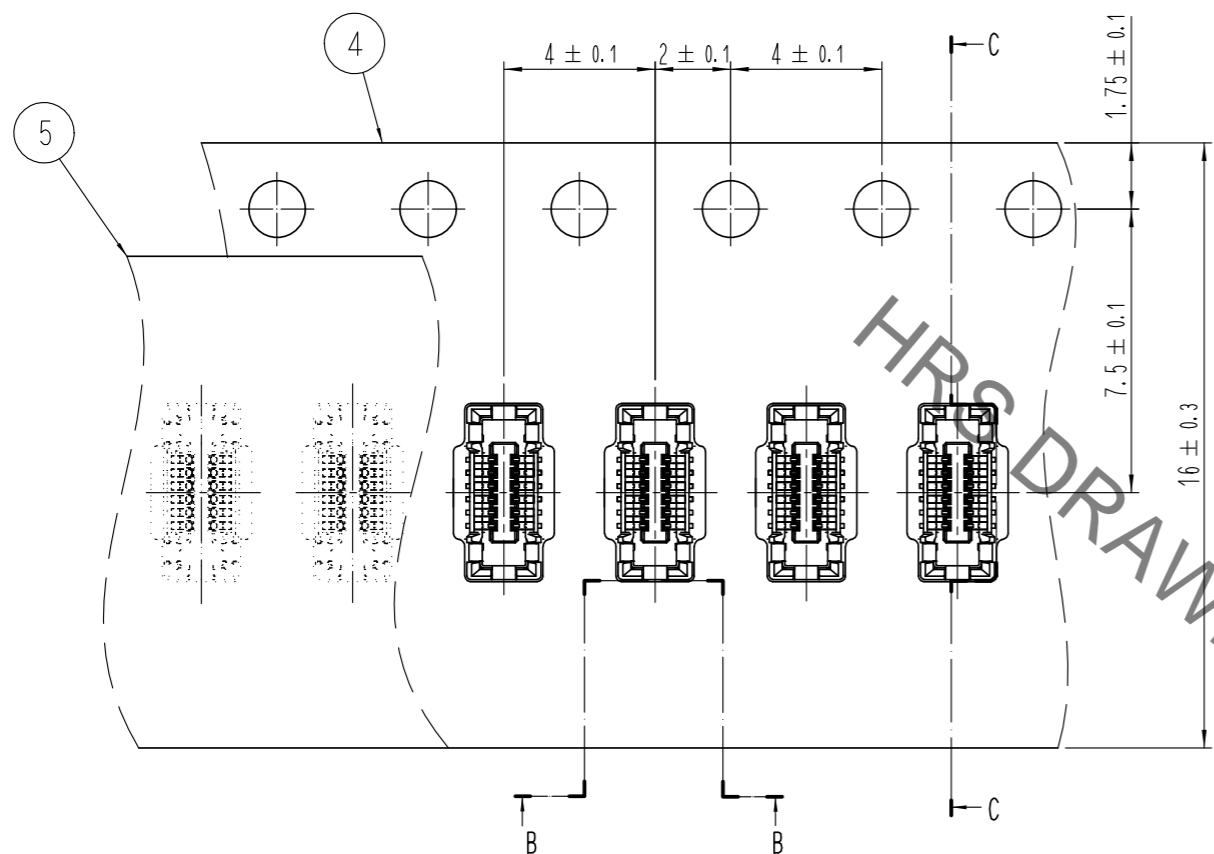

E-E (FREE)

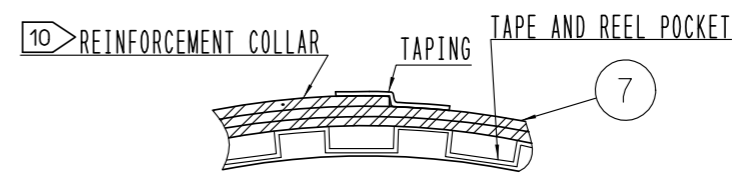

B-B (5:1)

DIRECTION OF UNREELING

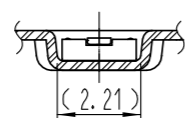

9 TAPING (FREE)

D (10:1)

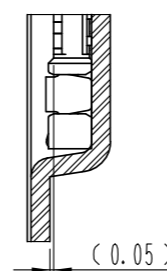

DETAIL OF PART No. LABEL

SUPPLIER	QUANTITY	PART NO.	CODE NO.	DATE OF MANUFACTURED
生産月日	年月日	箱番	** ** *	品名
		納入数量	1,000個	納入者
		HIROSE KOREA		

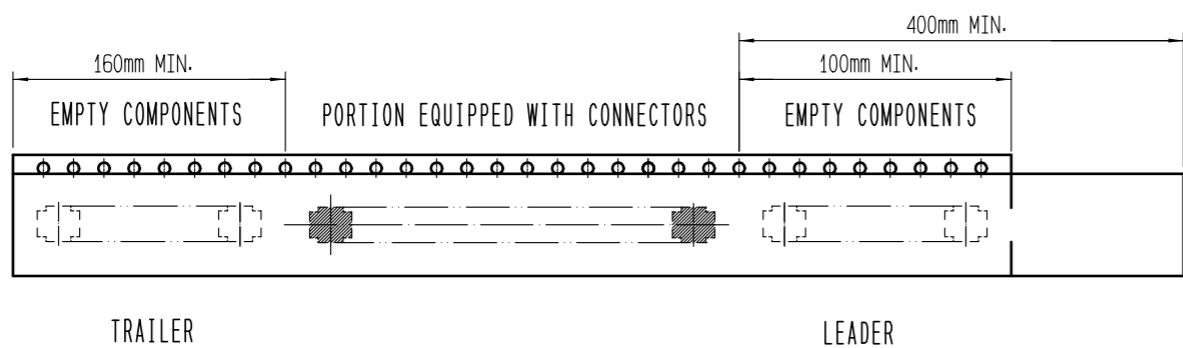

- 7 . PER REEL 1,000 CONNECTORS.
- 8 . THE DIMENSIONS IN PARENTHESES ARE FOR REFERENCE.
- 9 REFER TO JIS C 0806, IEC-60286-3 (PACKAGING OF COMPONENTS FOR AUTOMATIC HANDLING)
- 10 AFTER PACKAGING, ROLL 2 METERS OF THE REINFORCEMENT COLLAR TO OUTER CIRCUMFERENCE OF TAPE AND REEL POCKET. AND TAPE DOWN AT THE END THE COLLAR.

DRAWING NO. EDC3-632159	PART NO. BM23FR0.6-12DS-0.35V(895)	CODE NO. CL 6644-0077-9-895	3/3
HRS HIROSE KOREA CO., LTD.			

X-ON Electronics

Largest Supplier of Electrical and Electronic Components

Click to view similar products for [Board to Board & Mezzanine Connectors](#) category:

Click to view products by [Hirose](#) manufacturer:

Other Similar products are found below :

[589158040000018](#) [MDF7C-18P-2.54DSA\(55\)](#) [FCN-230C068-11](#) [FCN-268F012-G/BD](#) [FCN-268F036-G/BD](#) [FCN-268M012-G/0D](#) [FCN-268M024-G/1D](#) [FCN-723J004/1](#) [MIS-048-01-F-D-DP-K](#) [832-10-034-10-001000](#) [FX4C-80S-1.27DSA](#) [FCN-214Q030-G/0](#) [FCN-234P048-G/0](#) [FCN-235D050-G/C](#) [210-93-314-41-105000](#) [2-22603-0](#) [MDF7-40DP-2.54DSA\(55\)](#) [AXG720047](#) [MIT-114-03-F-D-K](#) [55323-1519](#) [DF33-2P-3.3DSA\(24\)](#) [YFT-20-05-H-03-SB-K](#) [503308-3040](#) [026-6203-PDB](#) [027-6203-PDB](#) [069159702701000](#) [10123981-102LF](#) [101A10019X](#) [55650-0588-C](#) [68682-310LF](#) [68684-306](#) [75140-7012](#) [87471-650](#) [YTW-30-07-H-Q-410-140](#) [FCN-268F024-G0D](#) [10124054-515LF](#) [68685-603](#) [8-1616154-3](#) [MIS-019-01-F-D](#) [FCN-268M024-G/3D](#) [FCN-268M036-G/BD](#) [20021832-06016C1LF](#) [KX15-20KLDL-E1000E](#) [AXE810124](#) [FCN-214J100-G/0](#) [FCN-230C068-E/S](#) [AXE812124](#) [AXE816124](#) [AXE720127](#) [354184](#)