

Sep.1.2021 Copyright 2021 HIROSE ELECTRIC CO., LTD. All Rights Reserved.  
In case of consideration for using Automotive equipment / device which demand high reliability, kindly contact our sales window correspondents.

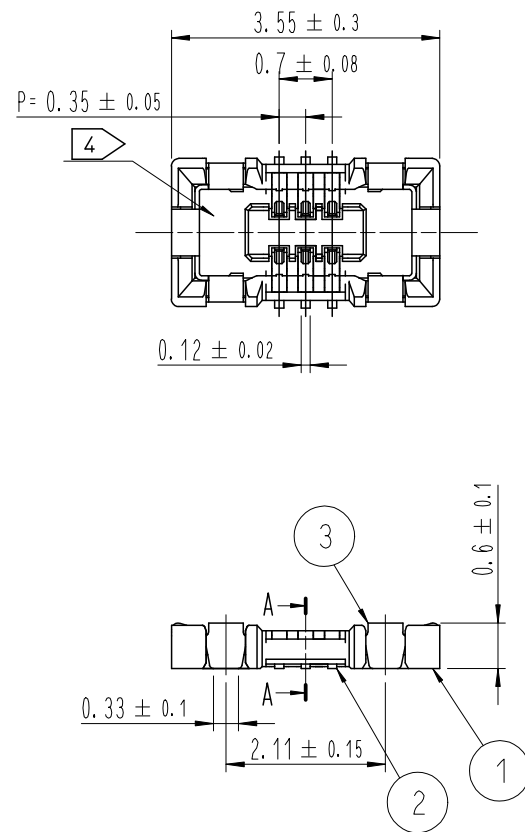

HRS DRAWING FOR REFERENCE

DRAWING FOR REFERENCE  
This is subject to change without notice

- NOTE
- 1 . ALL LEAD CO-PLANARITY SHALL BE 0.08mm MAX.
  - 2 CONTACT PLATING SPECIFICATIONS.  
CONTACT AREA : GOLD 0.05 μm MIN.  
SMT LEAD : GOLD 0.05 μm MIN.  
UNDERPLATING : NICKEL 1 μm MIN.  
( SURFACE : SEALING )
  - 3 MATAL FITTING PLATING SPECIFICATIONS.  
SMT LEAD : GOLD 0.05 μm MIN.  
UNDERPLATING : NICKEL 1 μm MIN.  
( SURFACE : SEALING )
  - 4 HRS MARK AND CAV NO. ARE INDICATED IN APPROX POSITION SHOWN.

COUNT	DESCRIPTION OF REVISIONS	B	Y	CHKD	DATE	COUNT	DESCRIPTION OF REVISIONS	B	Y	CHKD	DATE
△						△					
△						△					
△						△					

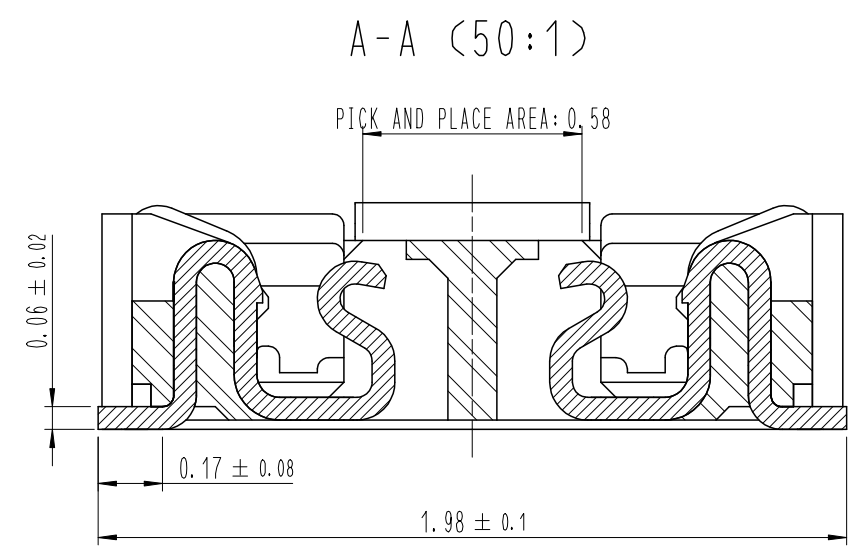

ENGAGEMENT FIGURE (50:1)

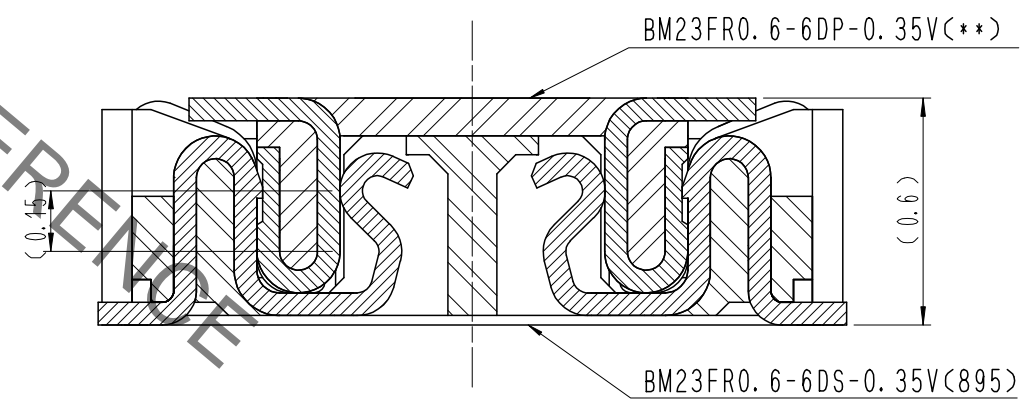

4	PS	CLEAR (EMBOSSD CARRIER TAPE)		7	PS	CLEAR (REINFORCEMENT COLLAR)		
3	COPPER ALLOY	3		6	PS	BLACK (PLASTIC REEL)		
2	COPPER ALLOY	2		5	POLYESTER	CLEAR (COVER TAPE)		
1	LCP	UL94 V-0, BLACK						
NO.	MATERIAL	FINISH , REMARKS		NO.	MATERIAL	FINISH , REMARKS		
REMARKS				DRAWN	DESIGNED	CHECKED	APPROVED	RELEASED
				S. H. JUNG	S. H. JUNG	H. W. JO	T. S. KANG	17. 05. 08
				17. 05. 08	17. 05. 08	17. 05. 08	17. 05. 08	
CODE NO. (OLD)	DRAWING NO. EDC3-632031			PART NO. BM23FR0.6-6DS-0.35V(895)				
SCALE 10:1	HRS HIROSE KOREA CO.,LTD.			CODE NO CL 6644-0057-1-895			1/3	
UNITS mm								

Sep.1.2021 Copyright 2021 HIROSE ELECTRIC CO., LTD. All Rights Reserved.  
In case of consideration for using Automotive equipment / device which demand high reliability, kindly contact our sales window correspondents.

6 RECOMMENDED PCB LAYOUT

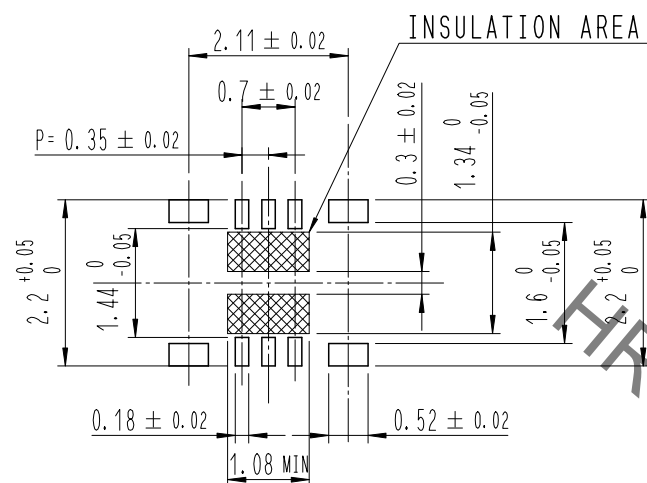

RECOMMENDED METAL MASK DIMENSIONS  
METAL MASK THICKNESS : 100 μm

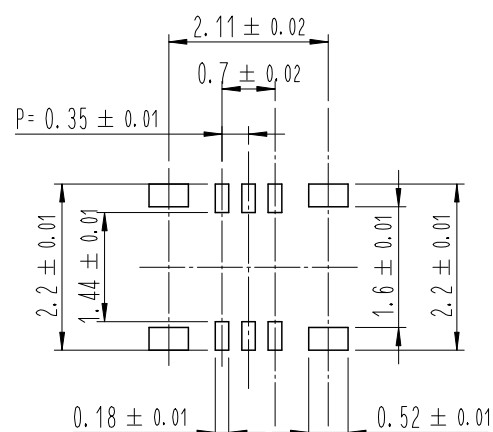

5 RECOMMENDED REFLOW TEMPERATURE PROFILE USING LEAD-FREE SOLDER PASTE.

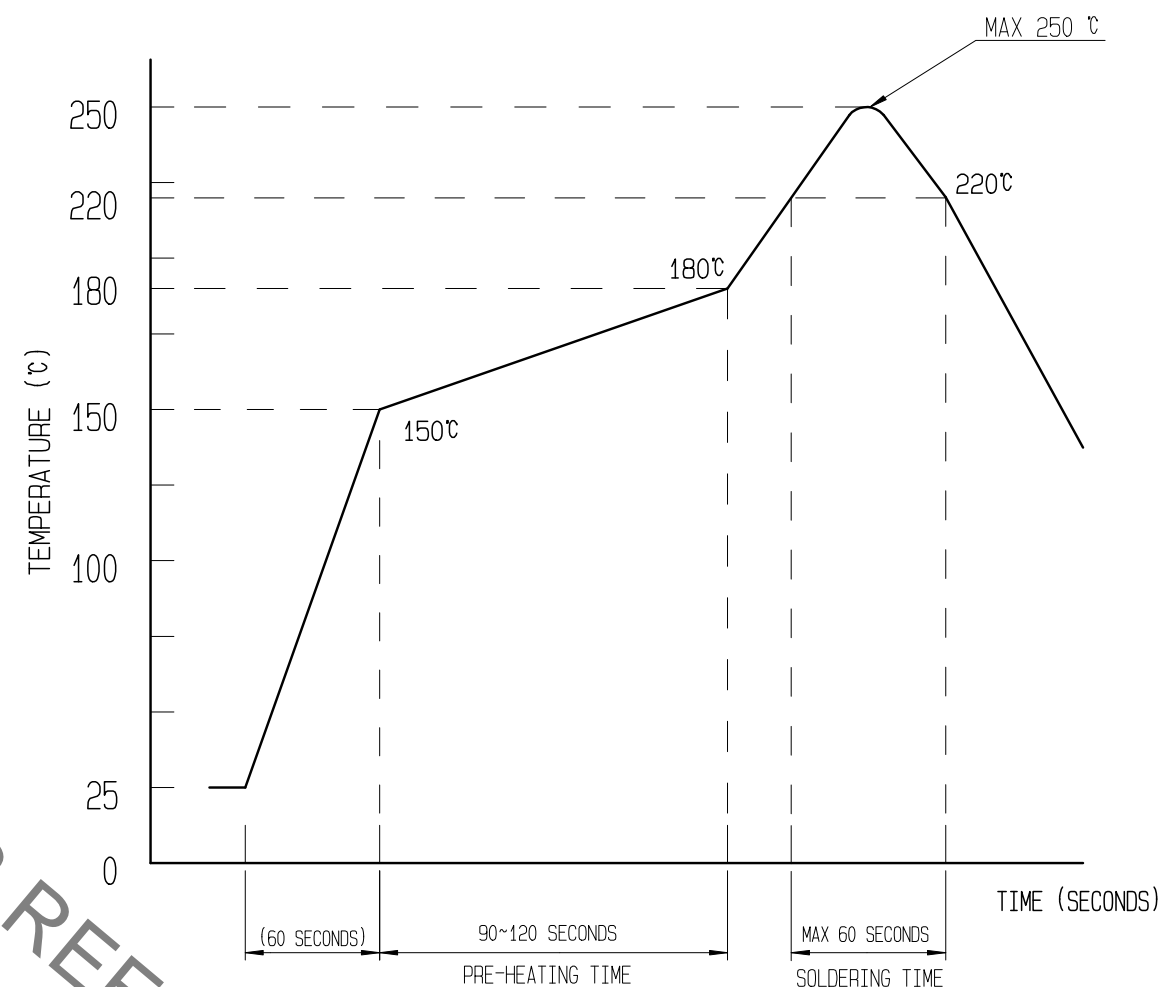

REFLOW METHOD: N2 REFLOW  
 NUMBER OF REFLOW CYCLES: 2 CYCLES MAX.  
 1) REFLOW TIME  
 DURATION ABOVE 220°C: 60 SEC MAX.  
 (PEAK TEMPERATURE: 250°C MAX)  
 2) PRE-HEAT TIME  
 PRE-HEAT TEMPERATURE(MIN): 150°C  
 PRE-HEAT TEMPERATURE(MAX): 180°C  
 PRE-HEAT TIME: 90-120 SEC.

- 5 THIS TEMPERATURE PROFILE IS PER THE CONDITIONS SHOWN ABOVE. ADDITIONAL FACTORS, SUCH AS SOLDER PASTE TYPE, PCB SIZE AND OTHER MOUNTED COMPONENTS COULD AFFECT THE PROFILE. THEREFORE, A THOROUGH EVALUATION OF MOUNTING CONDITION IS REQUIRED PRIOR TO PRODUCTION. TEMPERATURE IS MEASURED AT CONTACT LEAD.
- 6 PLEASE CONTACT US IN CASE YOU WILL MAKE DIFFERENT SETTINGS FROM OUR RECOMMENDATION.

	DRAWING NO.	EDC3-632031	PART NO.	BM23FR0.6-6DS-0.35V(895)
	SCALE	10:1	CODE NO	CL 6644-0057-1-895
UNITS	mm	HRS HIROSE KOREA CO., LTD.		2/3

Sep.1.2021 Copyright 2021 HIROSE ELECTRIC CO., LTD. All Rights Reserved.  
In case of consideration for using Automotive equipment / device which demand high reliability, kindly contact our sales window correspondents.

STYLE AND DIMENTION OF REEL (FREE)

EMBOSSED CARRIER TAPE PACKAGING (5:1)

C-C (5:1)

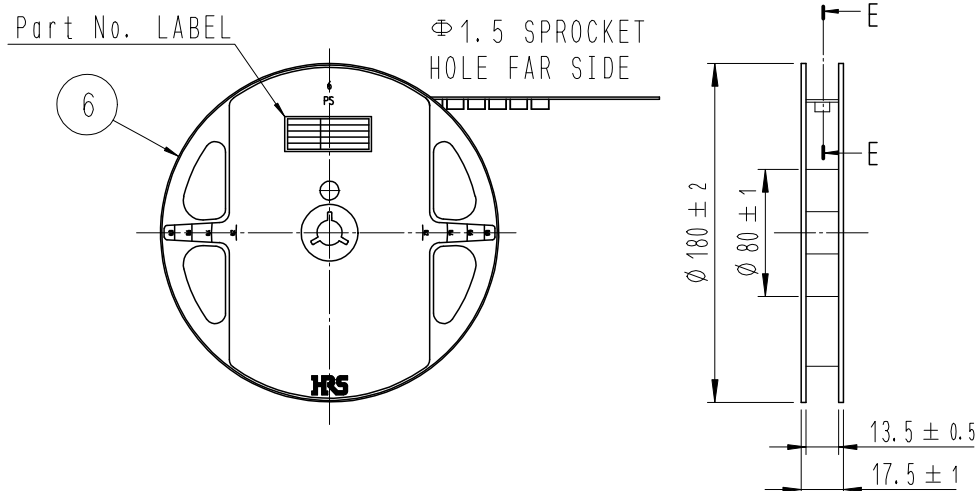
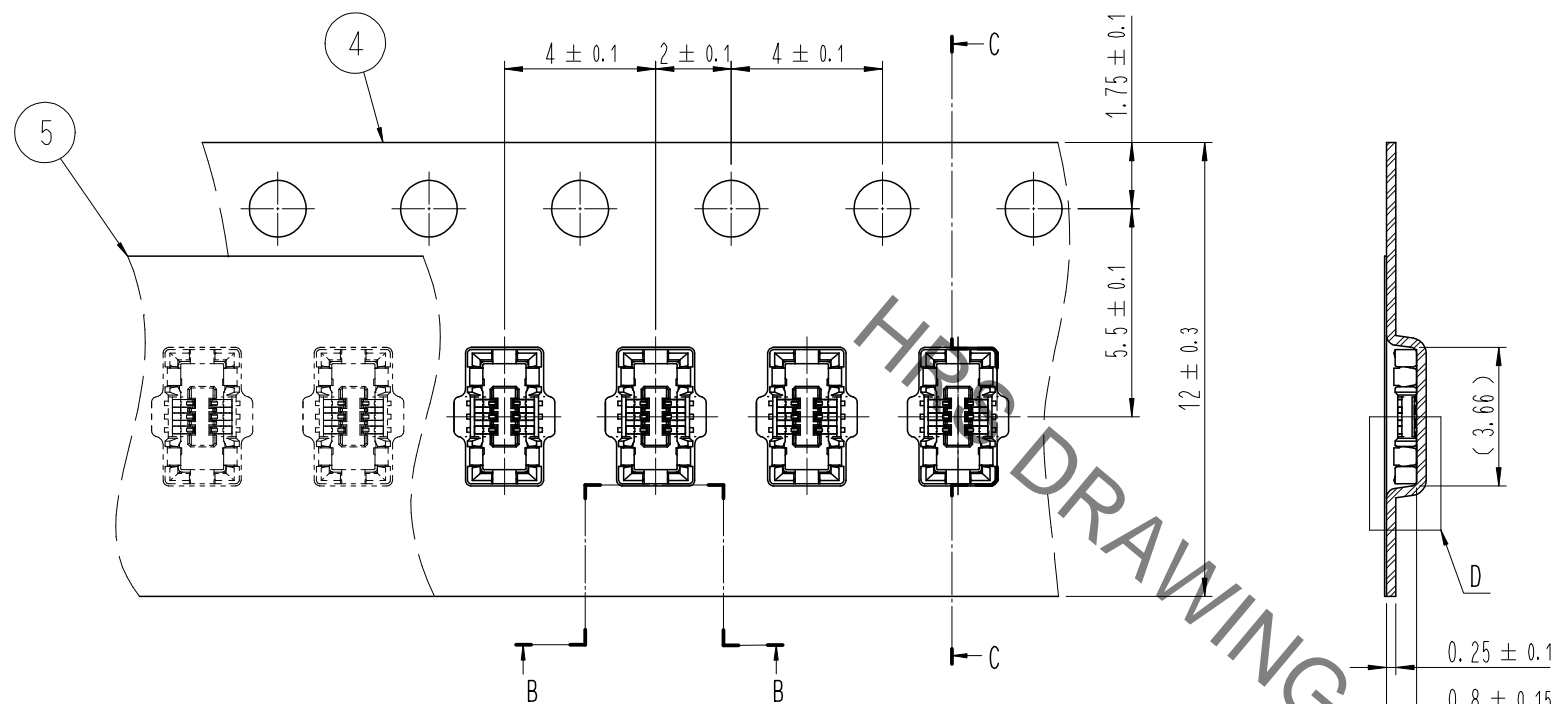

E-E (FREE)

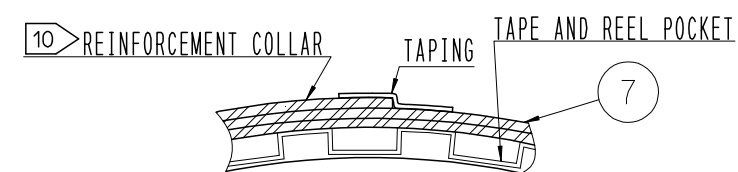

B-B (5:1)

DIRECTION OF UNREELING

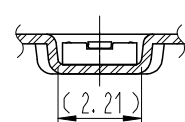

D (10:1)

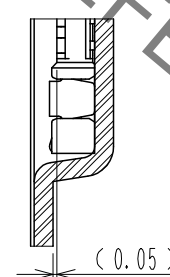

9 TAPING(FREE)

DETAIL OF PART No. LABEL

SUPPLIER	HIROSE ELECTRIC CO., LTD.
QUANTITY	1,000
PART NO.	BM23FR0.6-6DS-0.35V(895)
CODE NO.	CL 6644-0057-1-895
DATE OF MANUFACTURED	生産月日 年 月 日
図番	** ** *
品名	BM23FR0.6-6DS-0.35V(895)
納入数量	1,000個
納入者	HIROSE KOREA

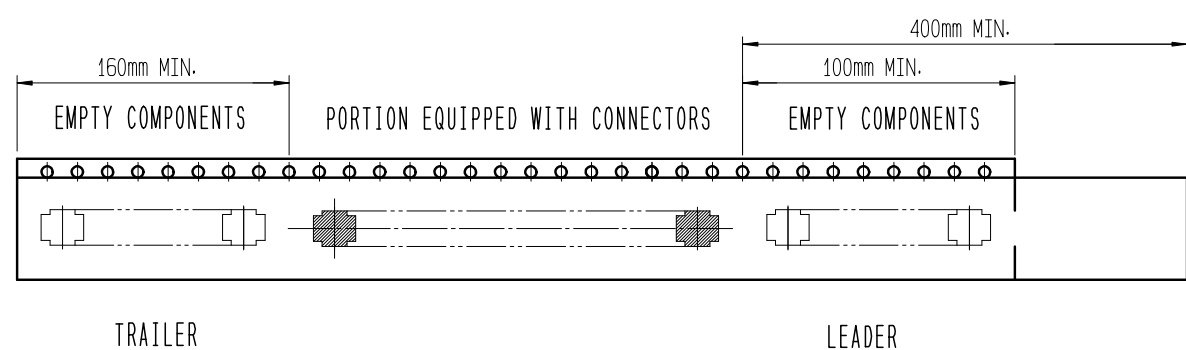

- 7 . PER REEL 1,000 CONNECTORS.
- 8 . THE DIMENSIONS IN PARENTHESSES ARE FOR REFERENCE.
- 9 REFER TO JIS C 0806, IEC-60286-3 (PACKAGING OF COMPONENTS FOR AUTOMATIC HANDLING)
- 10 AFTER PACKAGING, ROLL 2 METERS OF THE REINFORCEMENT COLLAR TO OUTER CIRCUMFERENCE OF TAPE AND REEL POCKET. AND TAPE DOWN AT THE END THE COLLAR.

DRAWING NO. EDC3-632031	PART NO. BM23FR0.6-6DS-0.35V(895)	CODE NO. CL 6644-0057-1-895	3/3
HIROSE ELECTRIC CO., LTD.			

## X-ON Electronics

Largest Supplier of Electrical and Electronic Components

*Click to view similar products for [Board to Board & Mezzanine Connectors](#) category:*

*Click to view products by [Hirose](#) manufacturer:*

Other Similar products are found below :

[589158040000018](#) [MDF7C-18P-2.54DSA\(55\)](#) [FCN-230C068-11](#) [FCN-268F012-G/BD](#) [FCN-268F036-G/BD](#) [FCN-268M012-G/0D](#) [FCN-268M024-G/1D](#) [FCN-723J004/1](#) [MIS-048-01-F-D-DP-K](#) [832-10-034-10-001000](#) [FX4C-80S-1.27DSA](#) [FCN-214Q030-G/0](#) [FCN-234P048-G/0](#) [FCN-235D050-G/C](#) [210-93-314-41-105000](#) [2-22603-0](#) [MDF7-40DP-2.54DSA\(55\)](#) [AXG720047](#) [MIT-114-03-F-D-K](#) [55323-1519](#) [DF33-2P-3.3DSA\(24\)](#) [YFT-20-05-H-03-SB-K](#) [503308-3040](#) [026-6203-PDB](#) [027-6203-PDB](#) [069159702701000](#) [10123981-102LF](#) [101A10019X](#) [55650-0588-C](#) [68682-310LF](#) [68684-306](#) [75140-7012](#) [87471-650](#) [YTW-30-07-H-Q-410-140](#) [FCN-268F024-G0D](#) [10124054-515LF](#) [68685-603](#) [8-1616154-3](#) [MIS-019-01-F-D](#) [FCN-268M024-G/3D](#) [FCN-268M036-G/BD](#) [20021832-06016C1LF](#) [KX15-20KLDL-E1000E](#) [AXE810124](#) [FCN-214J100-G/0](#) [FCN-230C068-E/S](#) [AXE812124](#) [AXE816124](#) [AXE720127](#) [354184](#)