

Aug.1.2021 Copyright 2021 HIROSE ELECTRIC CO., LTD. All Rights Reserved.
In case of consideration for using Automotive equipment / device which demand high reliability, kindly contact our sales window correspondents.

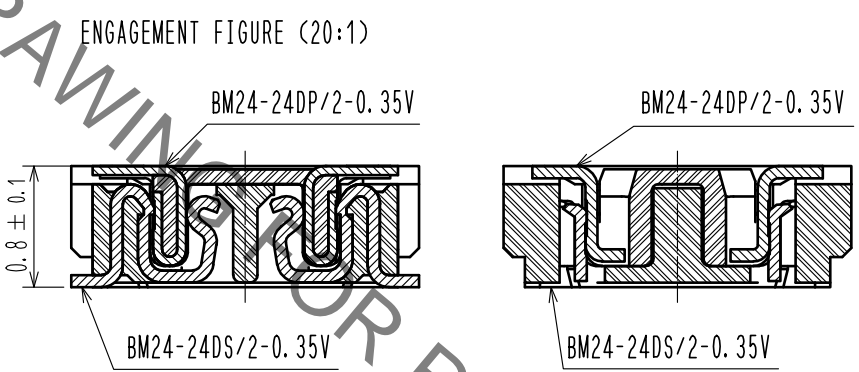

- NOTE 1 . ALL LEAD CO-PLANARITY SHALL BE 0.08mm MAX.
- 2 CONTACT PLATING SPECIFICATIONS
CONTACT AREA : GOLD 0.05 μm MIN
SMT LEAD : GOLD 0.05 μm MIN
UNDER PLATING : NICKEL 1 μm MIN
(SURFACE : SEALING)
 - 3 A PART OF THE WALL COULD BE NOTCHED.
 - 4 HRS MARK AND CAV No. ARE INDICATED IN APPROX. POSITION SHOWN.

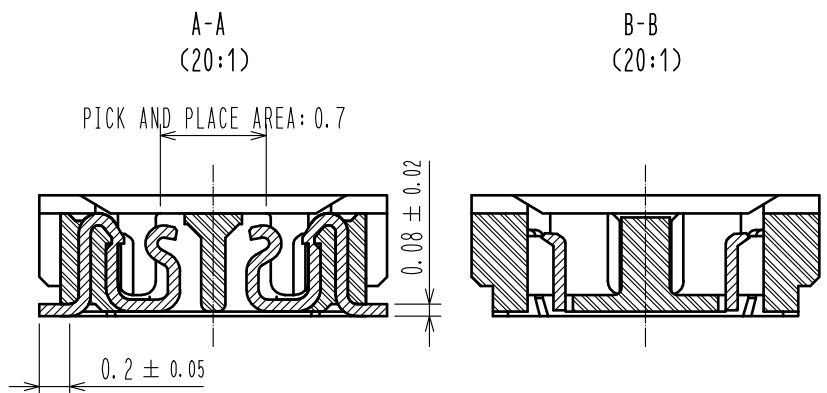
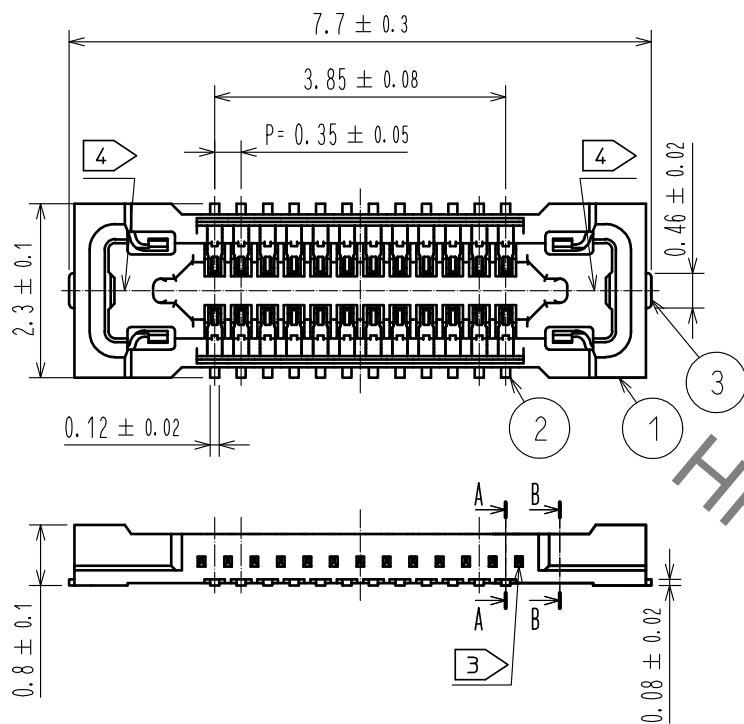
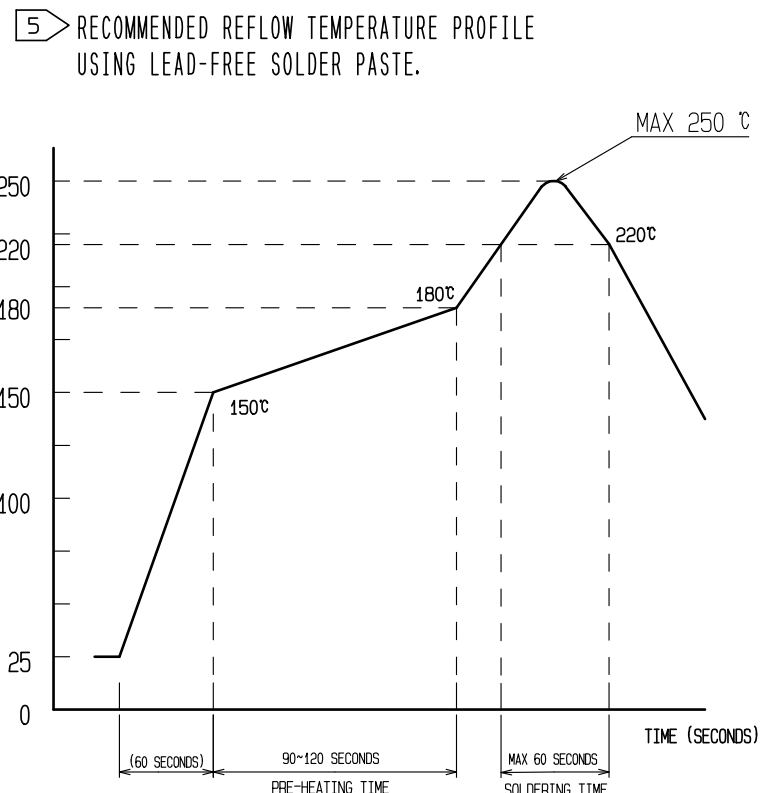

REFLOW METHOD: IR REFLOW
NUMBER OF REFLOW CYCLES: 2 CYCLES MAX.

1) REFLOW TIME
DURATION ABOVE 220°C, 60 SEC MAX.
(PEAK TEMPERATURE: 250°C MAX)

2) PRE-HEAT TIME
PRE-HEAT TEMPERATURE(MIN): 150°C
PRE-HEAT TEMPERATURE(MAX): 180°C
PRE-HEAT TIME: 90-120 SEC.

5 THIS TEMPERATURE PROFILE IS PER THE CONDITIONS SHOWN ABOVE. ADDITIONAL FACTORS, SUCH AS SOLDER PASTE TYPE, PCB SIZE AND OTHER MOUNTED COMPONENTS COULD AFFECT THE PROFILE. THEREFORE, A THOROUGH EVALUATION OF MOUNTING COONDITION IS REQUIRED PRIOR TO PRODUCTION. TEPERATURE IS MEASURED AT CONTACT LEAD.

6. PLEASE CONTACT US IN CASE YOU WILL MAKE DIFFERENT SETTINGS FROM OUR RECOMMENDATION.

◆ RECOMMENDED PCB LAYOUT

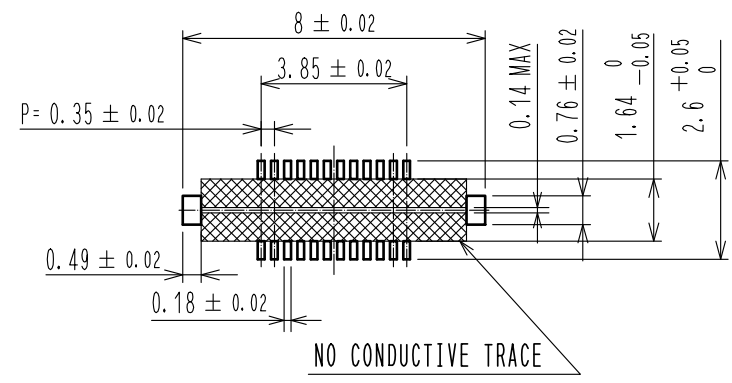

◆ RECOMMENDED METAL MASK DIMENSIONS
METAL MASK THICKNESS : 100 μm

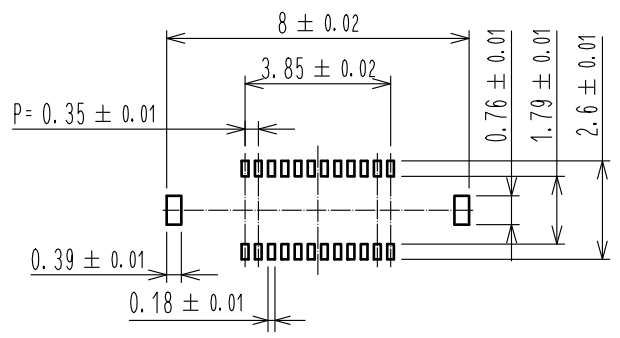

4	PS	CLEAR(EMBOSSED CARRIER TAPE)			
3	COPPER ALLOY	2	7	PS	CLEAR (REINFORCEMENT COLLAR)
2	COPPER ALLOY	2	6	PS	BLACK (PLASTIC REEL)
1	LCP	UL94 V-0. BLACK	5	POLYESTER	CLEAR (COVER TAPE)
NO.	MATERIAL	FINISH . REMARKS	NO.	MATERIAL	FINISH . REMARKS
UNITS mm		SCALE 10 : 1	COUNT 	DESCRIPTION OF REVISIONS	DESIGNED
HRS HIROSE ELECTRIC CO., LTD.		APPROVED : MO. ISHIDA	15.12.14	DRAWING NO.	EDC-353452-53-01
		CHECED : TS. MIYAZAKI	15.12.14	PART NO.	BM24-24DS/2-0.35V(53)
		DESIGNED : NY. YAMASHIRO	15.12.14	CODE NO.	CL677-2006-2-53
		DRAWN : KR. AJITO	15.12.11		1/2

Aug.1.2021 Copyright 2021 HIROSE ELECTRIC CO., LTD. All Rights Reserved.
 In case of consideration for using Automotive equipment / device which demand high reliability, kindly contact our sales window correspondents.

EMBOSSED CARRIER TAPE PACKAGING (FREE)

STYLE AND DIMENTION OF REEL (FREE)

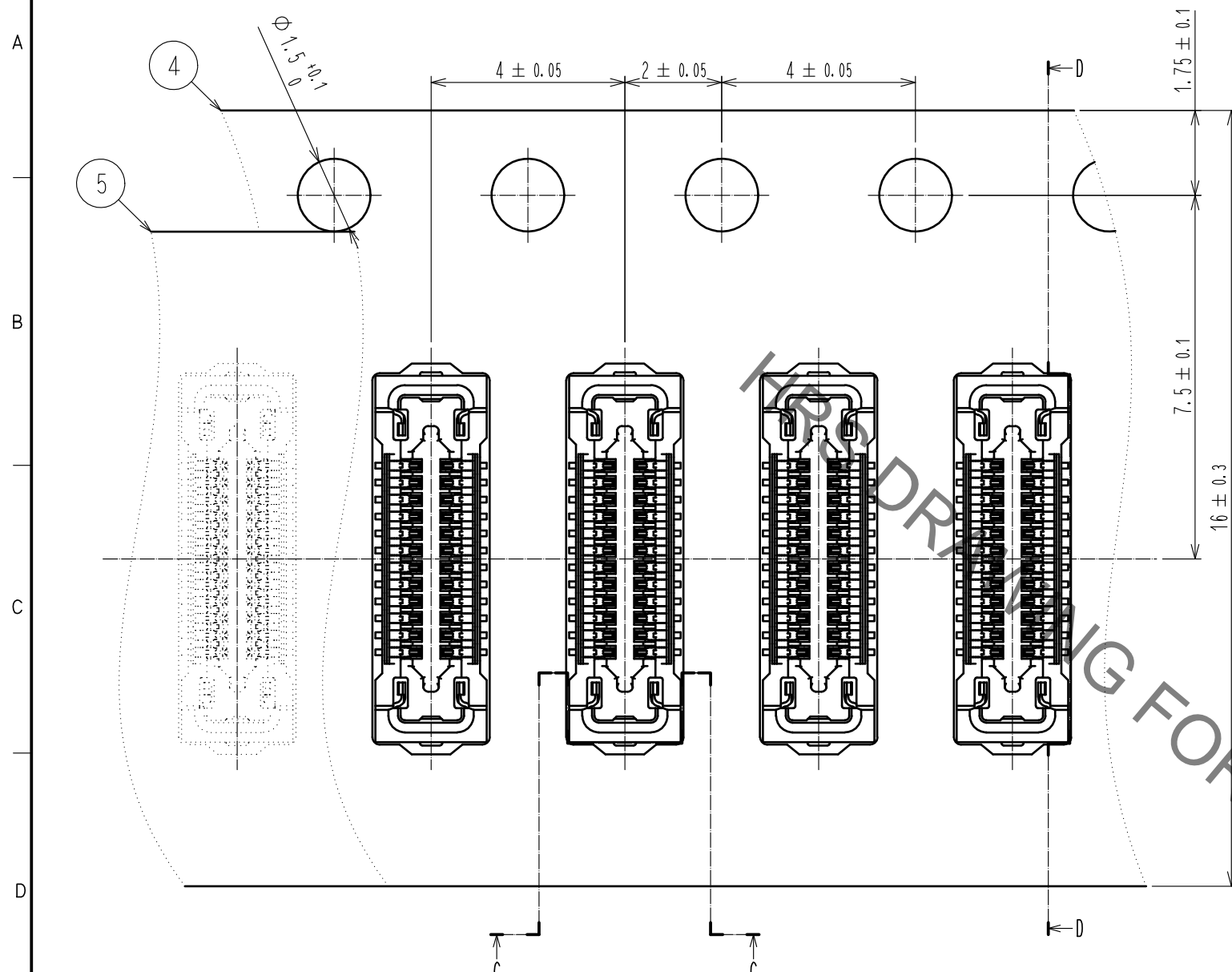

D-D (FREE)

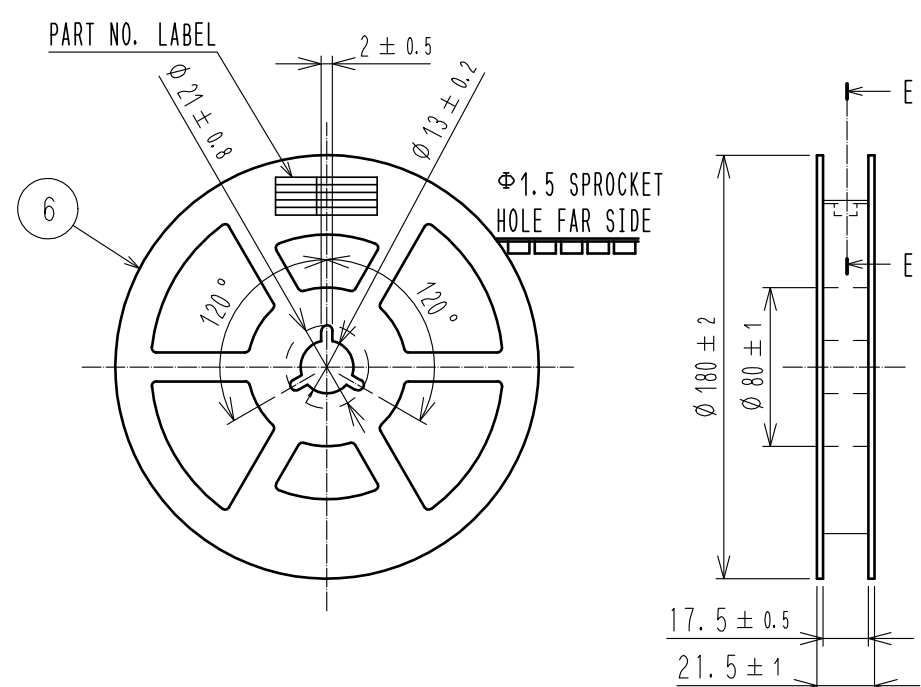
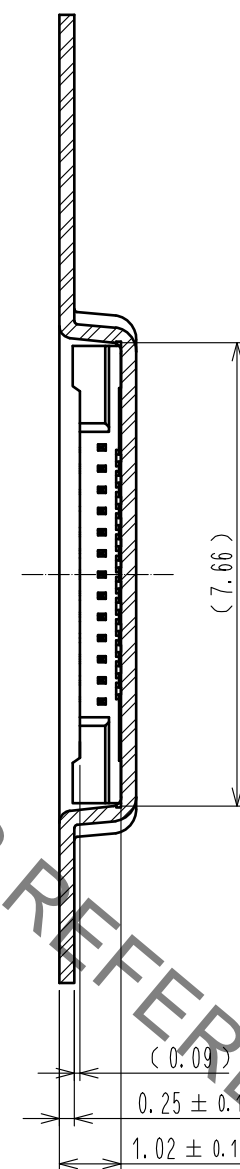

E-E (FREE)

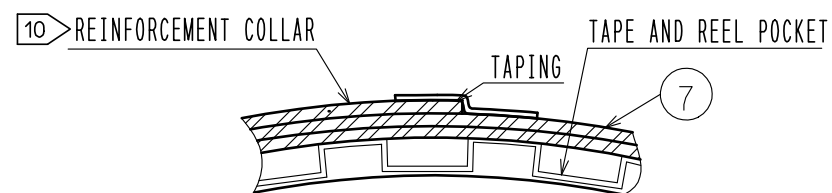

DETAIL OF PART NO. LABEL

製造年月日	** ** *	DATA OF MANUFACTURED
製品コード	CL0677-2006-2(53)	CODE NO.
製品名	BM24-24DS/2-0.35V(53)	PART NO.
数量	1,000	QUANTITY
納入者	ヒロセ電機(株)	SUPPLIER

- 7 . PER REEL 1,000 CONNECTORS.
- 8 . THE DIMENSIONS IN PARENTHESES ARE FOR REFERENCE.
- 9 . REFER TO JIS C 0806, IEC 60286-3(PACKAGING OF COMPONENTS FOR AUTOMATIC HANDLING)
- 10 . AFTER PACKAGING, ROLL 2 METERS OF THE REINFORCEMENT COLLAR TO OUTER CIRCUMFERENCE OF TAPE AND REEL POCKET, AND TAPE DOWN AT THE END THE COLLAR.

DIRECTION OF UNREELING

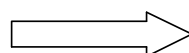

C-C (FREE)

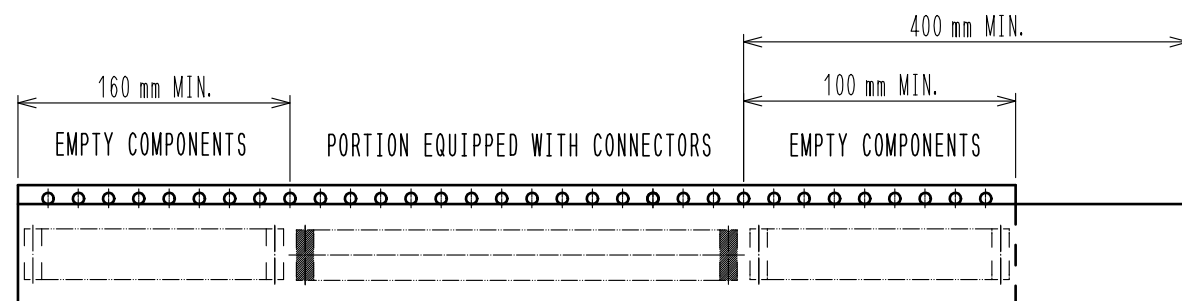
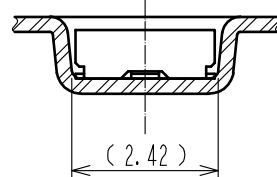

9 TAPING(FREE)

HRS	DRAWING NO.	EDC-353452-53-01
	PART NO.	BM24-24DS/2-0.35V(53)
	CODE NO.	CL677-2006-2-53
		\triangle 2/2

X-ON Electronics

Largest Supplier of Electrical and Electronic Components

Click to view similar products for [Board to Board & Mezzanine Connectors](#) category:

Click to view products by [Hirose](#) manufacturer:

Other Similar products are found below :

[589158040000018](#) [MDF7C-18P-2.54DSA\(55\)](#) [FCN-230C068-11](#) [FCN-268F012-G/BD](#) [FCN-268F036-G/BD](#) [FCN-268M012-G/0D](#) [FCN-268M024-G/1D](#) [FCN-723J004/1](#) [MIS-048-01-F-D-DP-K](#) [832-10-034-10-001000](#) [FX4C-80S-1.27DSA](#) [FCN-214Q030-G/0](#) [FCN-234P048-G/0](#) [FCN-235D050-G/C](#) [210-93-314-41-105000](#) [2-22603-0](#) [MDF7-40DP-2.54DSA\(55\)](#) [AXG720047](#) [MIT-114-03-F-D-K](#) [55323-1519](#) [DF33-2P-3.3DSA\(24\)](#) [YFT-20-05-H-03-SB-K](#) [503308-3040](#) [026-6203-PDB](#) [027-6203-PDB](#) [069159702701000](#) [10123981-102LF](#) [101A10019X](#) [55650-0588-C](#) [68682-310LF](#) [68684-306](#) [75140-7012](#) [87471-650](#) [YTW-30-07-H-Q-410-140](#) [FCN-268F024-G0D](#) [10124054-515LF](#) [68685-603](#) [8-1616154-3](#) [MIS-019-01-F-D](#) [FCN-268M024-G/3D](#) [FCN-268M036-G/BD](#) [20021832-06016C1LF](#) [KX15-20KLDL-E1000E](#) [AXE810124](#) [FCN-214J100-G/0](#) [FCN-230C068-E/S](#) [AXE812124](#) [AXE816124](#) [AXE720127](#) [354184](#)