

Dec.1.2018 Copyright 2018 HIROSE ELECTRIC CO., LTD. All Rights Reserved.
 In case that the application demands a high level of reliability, such as automotive,
 please contact a company representative for further information.

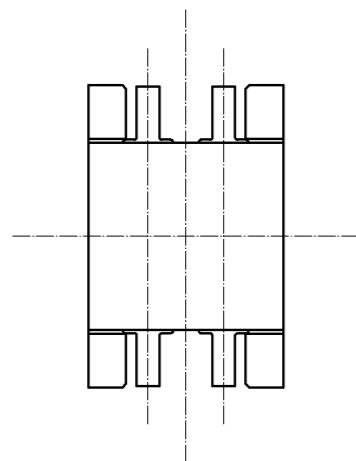

NOTE 1. LEAD CO-PLANARITY SHALL BE 0.1mm MAX.
 2. THIS PRODUCT TO BE SHIPPED BY TAPE AND REEL PACKAGE.
 REFER TO NEXT SHEET FOR DETAILS PACKAGING SPECIFICATIONS.
 [3] PLATING SPECIFICATION
 CONTACT AREA : GOLD 0.1 μm MIN.
 LEAD : GOLD 0.05 μm MIN.
 OTHERS(UNDER PLATING) : NICKEL 1 μm MIN.
 GOLD PLATING IS ALLOWED TO THE OTHER SURFACE
 THAN LEAD AREA AND CONTACT AREA.

RECOMMENDED PATTERN FOR MOUNTING (5:1)

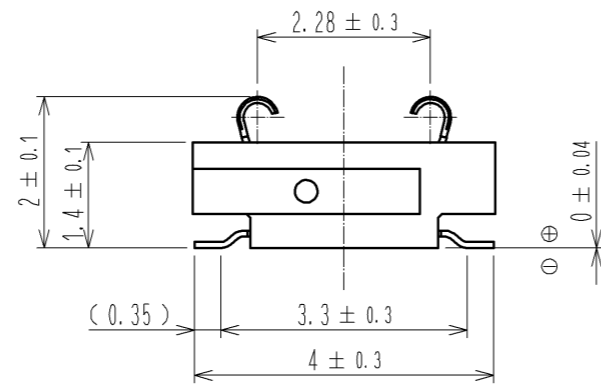
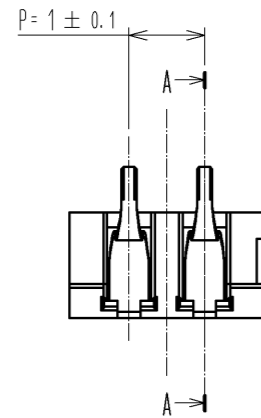
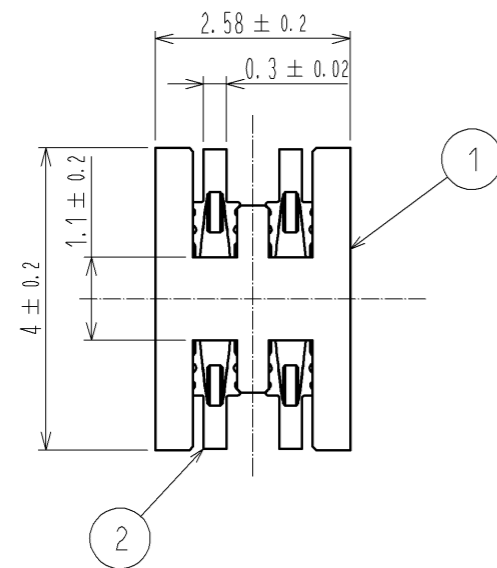
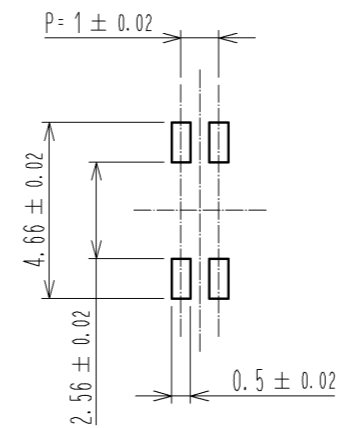

RECOMMENDED SOLDER PASTE: THICKNESS 100 μm

RECOMMENDED PATTERN FOR MATING (5:1)

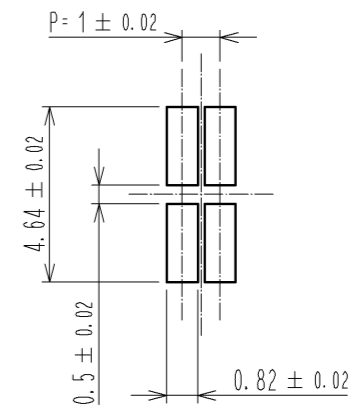

RECOMMENDED PLATING SPECIFICATION
 GOLD 0.2 μm MIN OVER NICKEL 1 μm ~ 5 μm.

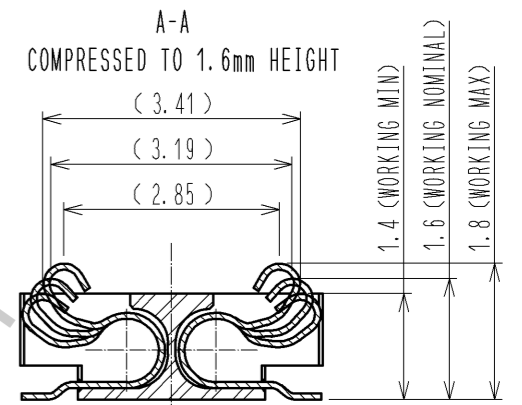
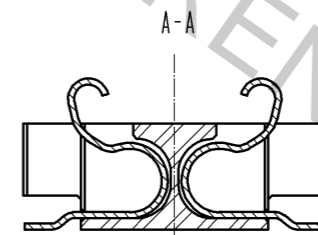
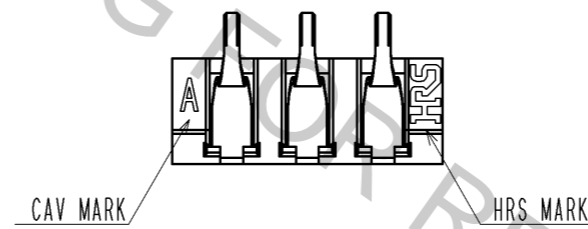

3	PS	CLEAR(EMBOSSED CARRIER TAPE)	6	PS	CLEAR(REINFORCING COLLAR)
2	PHOSPHOR BRONZE	[3]	5	PS	BLACK(PLASTIC REEL)
1	LCP	UL94V-0, BLACK	4	POLYESTER	CLEAR(COVER TAPE)
NO.	MATERIAL	FINISH, REMARKS	NO.	MATERIAL	FINISH, REMARKS
UNITS mm		SCALE 10:1	COUNT △	DESCRIPTION OF REVISIONS	
DESIGNED		CHECKED		DATE	
APPROVED : KH. IKEDA		12.02.28		DRAWING NO. EDC3-337230-01	
CHECKED : TS. MIYAZAKI		12.02.28		PART NO. BM26YC1.4-4DCP-1.0V(63)	
DESIGNED : TY. YAMASAKI		12.02.28		CODE NO. CL661-2022-3-63	
DRAWN : TY. YAMASAKI		12.02.28		△ 1/2	

Dec.1.2018 Copyright 2018 HIROSE ELECTRIC CO., LTD. All Rights Reserved.
 In case that the application demands a high level of reliability, such as automotive,
 please contact a company representative for further information.

EMBOSSED CARRIER TAPE PACKAGING(5:1)

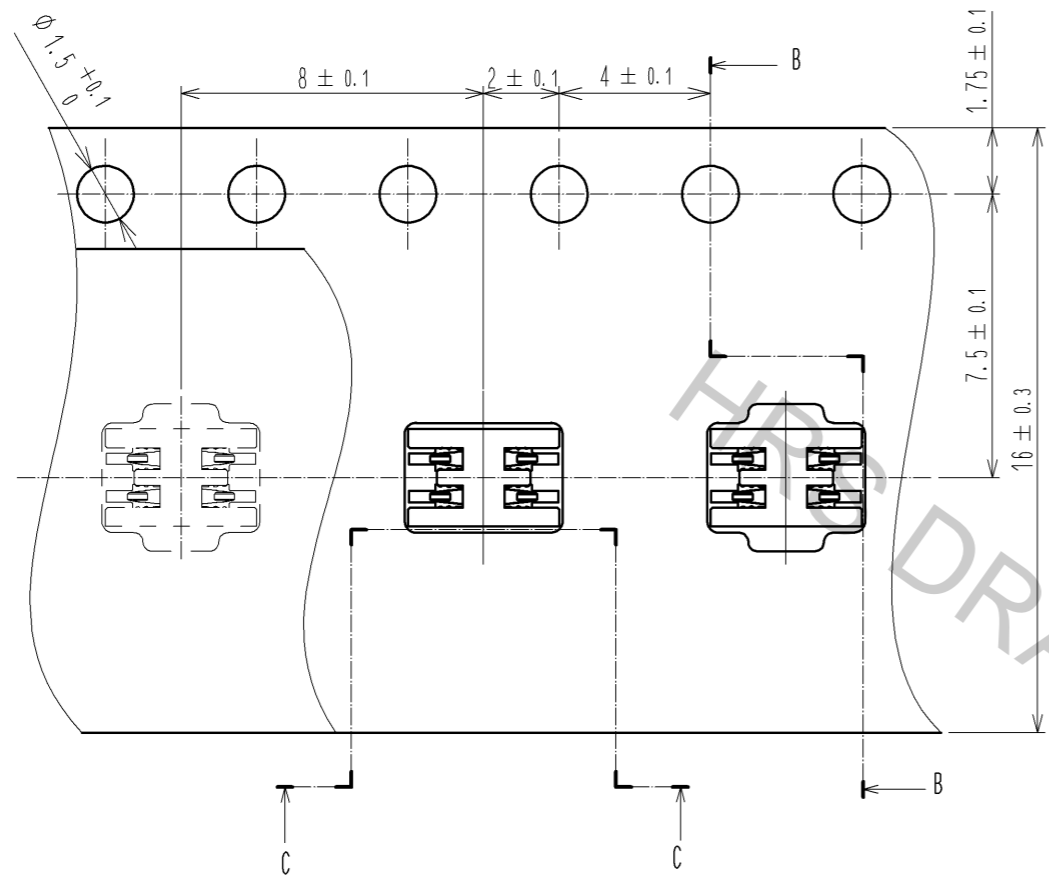

B-B (5:1)

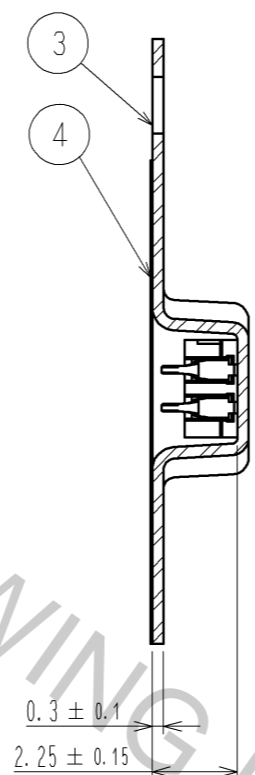

STYLE AND DIMENSION OF REEL(FREE SIZE)

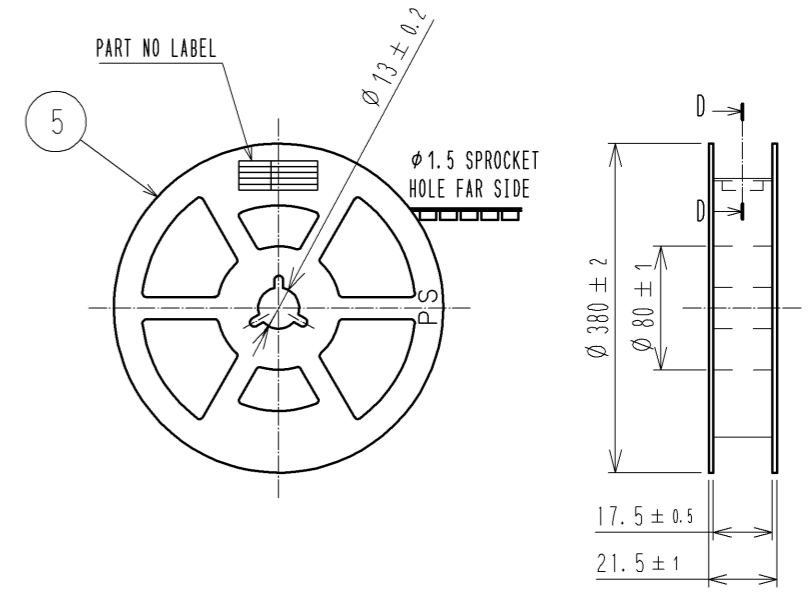

7 DETAIL OF PART No. LABEL

SUPPLIER	
QUANTITY	
PART NO.	
CODE NO.	
DATE OF MANUFACTURED	
製造年月日	年 月 日
製品コード	** ** *
製品名	BM26YC1.4-4DCP-1.0V(63)
数量	4000個
納入者	ヒロセ電機(株)

8 D-D (FREE SIZE)

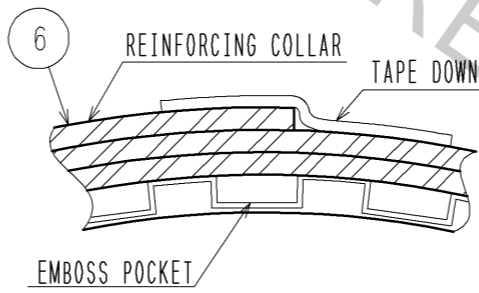

C-C (5:1)

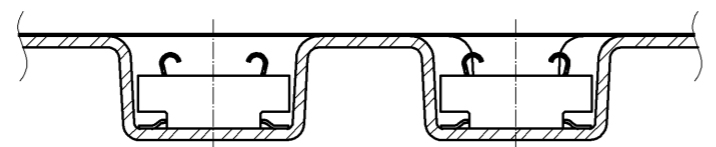

DIRECTION OF UNREELING

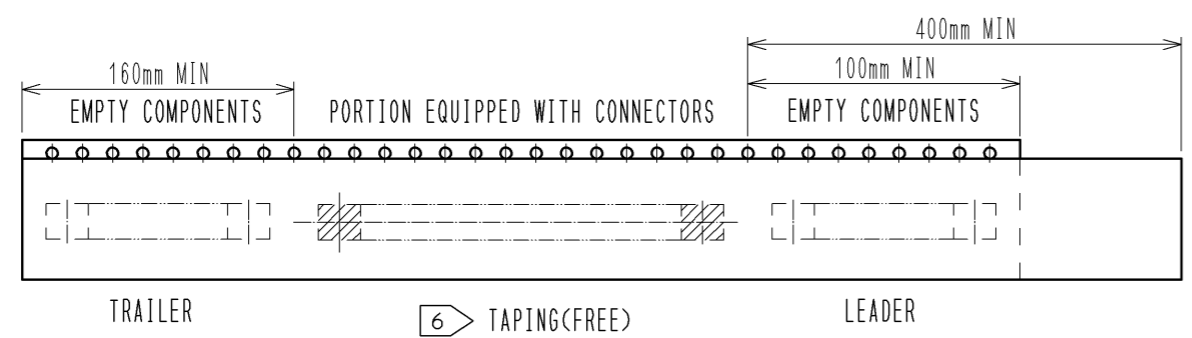

- NOTE
- 4. PER REEL 4000 CONNECTORS.
 - 5. THE DIMENSIONS IN PARENTHESES ARE FOR REFERENCE.
 - 6. REFER TO JIS C 0806(IEC 60286-3)(PACKING OF COMPONENTS FOR AUTOMATIC HANDLING)
 - 7. DETAIL OF PART NO. LABEL IS WRITTEN IN JAPANESE.
 - 8. AFTER PACKING, WRAP AROUND THE REELED POCKET WITH 2m LENGTH REINFORCING COLLAR AND TAPE DOWN AT THE END.

HRS	DRAWING NO.	EDC3-337230-01
	PART NO.	BM26YC1.4-4DCP-1.0V(63)
	CODE NO.	CL661-2022-3-63
		\triangle 2/2

X-ON Electronics

Largest Supplier of Electrical and Electronic Components

Click to view similar products for [Board to Board & Mezzanine Connectors](#) category:

Click to view products by [Hirose](#) manufacturer:

Other Similar products are found below :

[589158040000018](#) [MDF7C-18P-2.54DSA\(55\)](#) [FCN-230C068-11](#) [FCN-268F012-G/BD](#) [FCN-268F036-G/BD](#) [FCN-268M012-G/0D](#) [FCN-268M024-G/1D](#) [FCN-723J004/1](#) [MIS-048-01-F-D-DP-K](#) [832-10-034-10-001000](#) [FX4C-80S-1.27DSA](#) [FCN-214Q030-G/0](#) [FCN-234P048-G/0](#) [FCN-235D050-G/C](#) [210-93-314-41-105000](#) [2-22603-0](#) [MDF7-40DP-2.54DSA\(55\)](#) [AXG720047](#) [MIT-114-03-F-D-K](#) [55323-1519](#) [DF33-2P-3.3DSA\(24\)](#) [YFT-20-05-H-03-SB-K](#) [503308-3040](#) [026-6203-PDB](#) [027-6203-PDB](#) [069159702701000](#) [10123981-102LF](#) [101A10019X](#) [55650-0588-C](#) [68682-310LF](#) [68684-306](#) [75140-7012](#) [87471-650](#) [YTW-30-07-H-Q-410-140](#) [FCN-268F024-G0D](#) [10124054-515LF](#) [68685-603](#) [8-1616154-3](#) [MIS-019-01-F-D](#) [FCN-268M024-G/3D](#) [FCN-268M036-G/BD](#) [20021832-06016C1LF](#) [KX15-20KLDL-E1000E](#) [AXE810124](#) [FCN-214J100-G/0](#) [FCN-230C068-E/S](#) [AXE812124](#) [AXE816124](#) [AXE720127](#) [354184](#)