

Aug.1.2021 Copyright 2021 HIROSE ELECTRIC CO., LTD. All Rights Reserved.
In case of consideration for using Automotive equipment / device which demand high reliability, kindly contact our sales window correspondents.

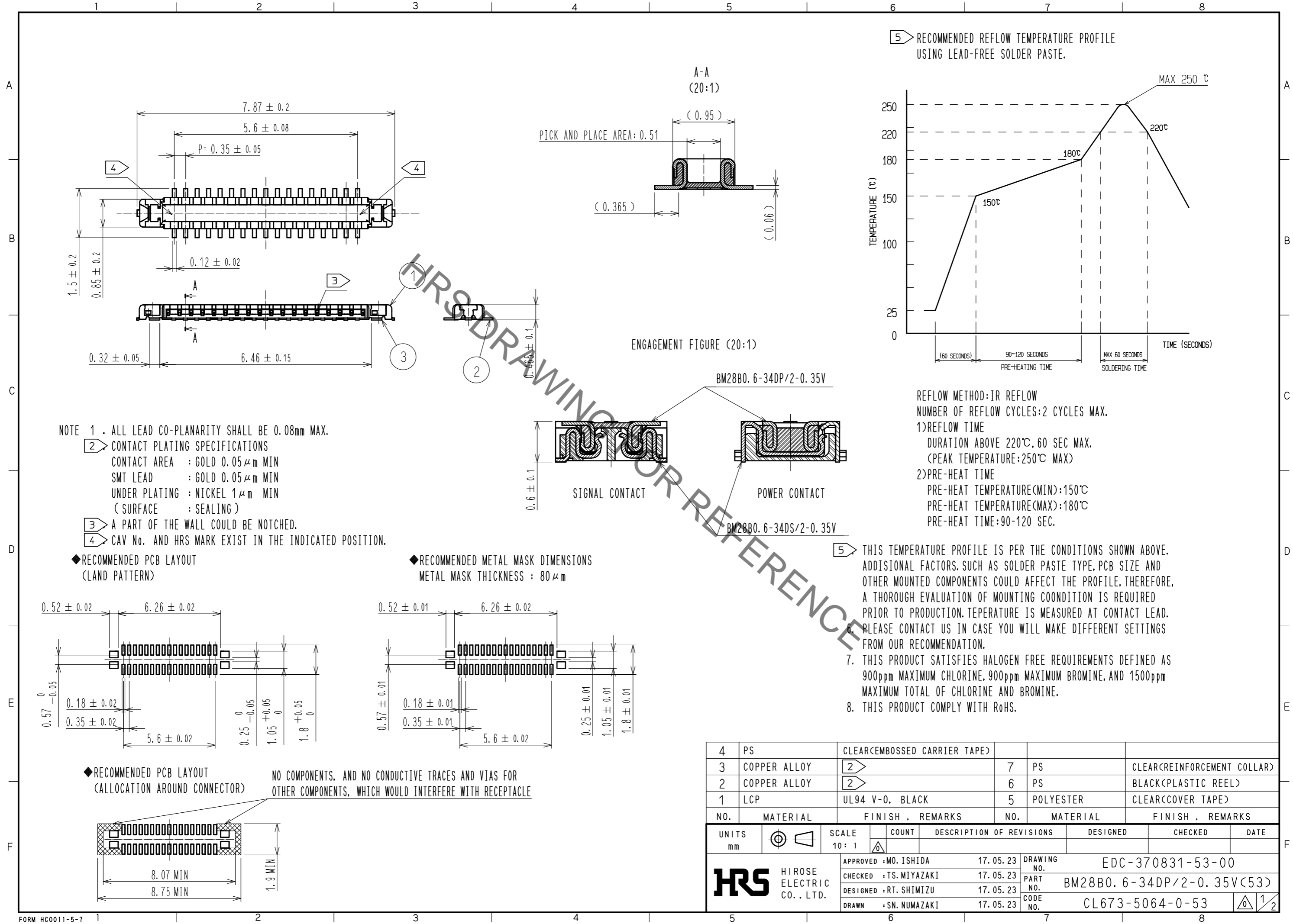

4	PS	CLEAR(EMBOSSED CARRIER TAPE)			
3	COPPER ALLOY	2	7	PS	CLEAR(REINFORCEMENT COLLAR)
2	COPPER ALLOY	2	6	PS	BLACK(PLASTIC REEL)
1	LCP	UL94 V-0, BLACK	5	POLYESTER	CLEAR(COVER TAPE)
NO.	MATERIAL	FINISH . REMARKS	NO.	MATERIAL	FINISH . REMARKS
UNITS mm		SCALE 10:1	COUNT	DESCRIPTION OF REVISIONS	DESIGNED
HRS	HIROSE ELECTRIC CO., LTD.	APPROVED : MO. ISHIDA	17.05.23	DRAWING NO.	EDC-370831-53-00
		CHECKED : TS. MIYAZAKI	17.05.23	PART NO.	BM28B0. 6-34DP/2-0.35V(53)
		DESIGNED : RT. SHIMIZU	17.05.23	CODE NO.	CL673-5064-0-53
		DRAWN : SN. NUMAZAKI	17.05.23		1/2

Aug.1.2021 Copyright 2021 HIROSE ELECTRIC CO., LTD. All Rights Reserved.
In case of consideration for using Automotive equipment / device which demand high reliability, kindly contact our sales window correspondents.

EMBOSED CARRIER TAPE PACKAGING (5:1)

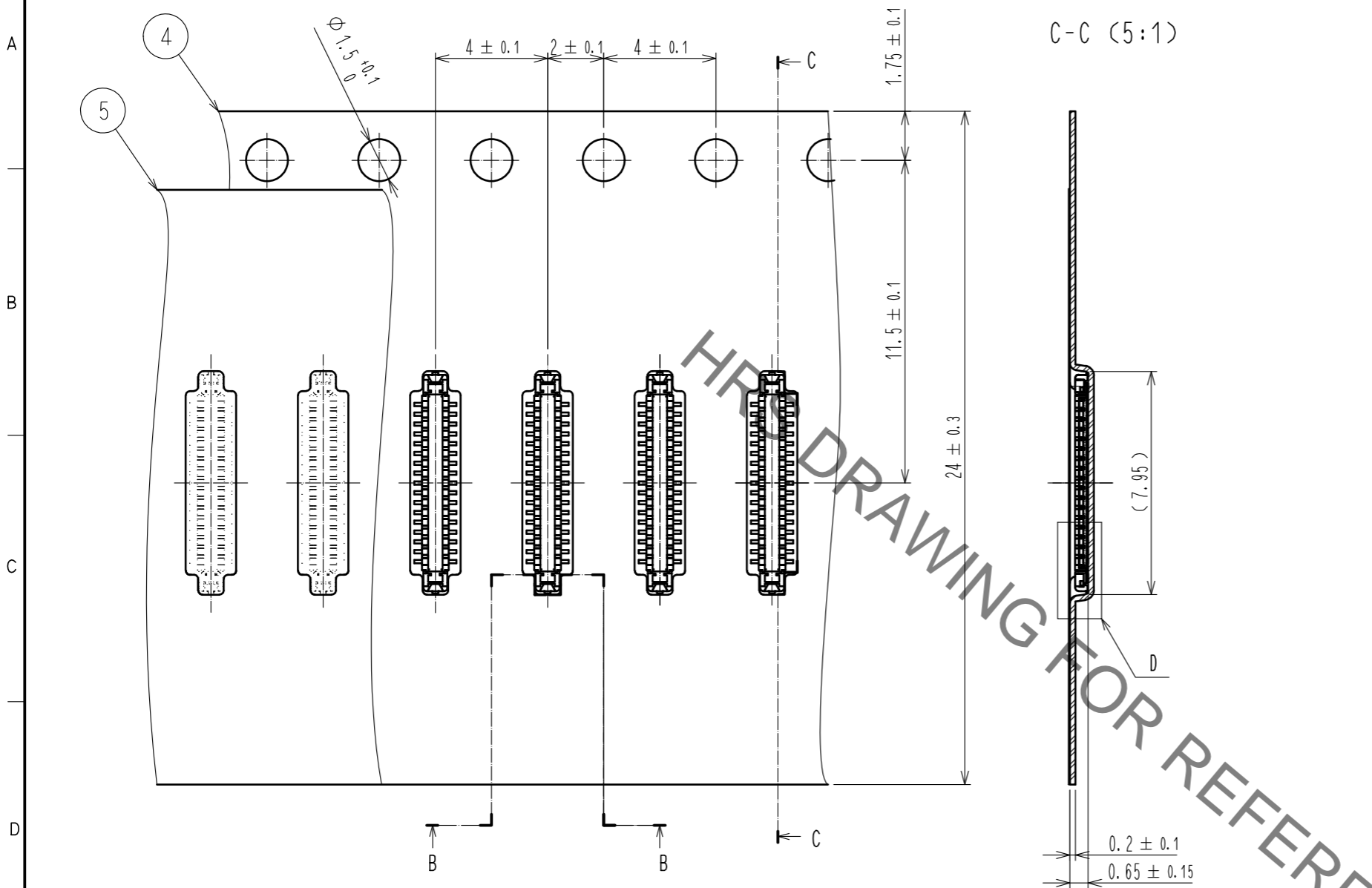

STYLE AND DIMENSION OF REEL (FREE)

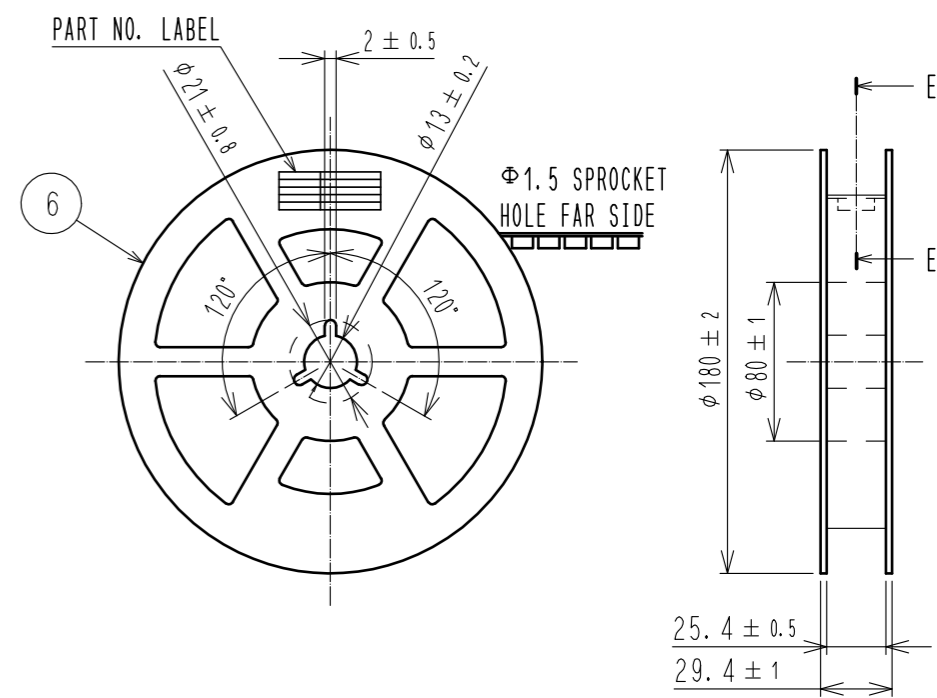

E-E (FREE)

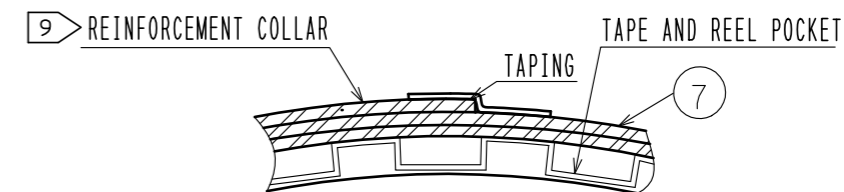

B-B (5:1)

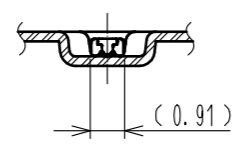

DIRECTION OF UNREELING →

D (10:1)

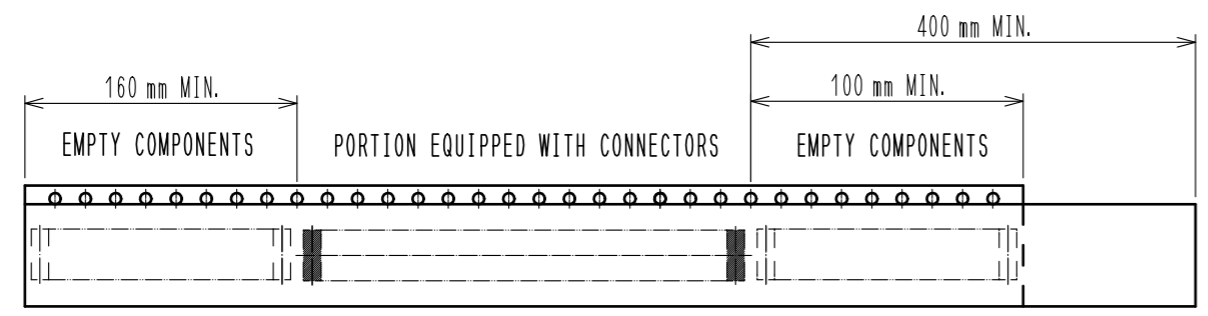
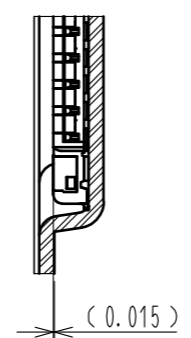

12 TAPING(FREE)

DETAIL OF PART NO. LABEL

製造年月日	** ** *	DATA OF MANUFACTURED
製品コード	CL0673-****-**	CODE NO.
製品名	BM28B0.6-**	PART NO.
数量	1,000	QUANTITY
納入者	ヒロセ電機(株)	SUPPLIER

- 9. AFTER PACKAGING. ROLL 2 METERS OF THE REINFORCEMENT COLLAR TO OUTER CIRCUMFERENCE OF TAPE AND REEL POCKET. AND TAPE DOWN AT THE END THE COLLAR.
- 10. PER REEL 1,000 CONNECTORS.
- 11. THE DIMENSIONS IN PARENTHESES ARE FOR REFERENCE.
- 12. REFER TO JIS C 0806, IEC 60286-3(PACKAGING OF COMPONENTS FOR AUTOMATIC HANDLING)

HRS	DRAWING NO.	EDC-370831-53-00
	PART NO.	BM28B0.6-34DP/2-0.35V(53)
	CODE NO.	CL673-5064-0-53
		△ 2/2

X-ON Electronics

Largest Supplier of Electrical and Electronic Components

Click to view similar products for [Board to Board & Mezzanine Connectors](#) category:

Click to view products by [Hirose](#) manufacturer:

Other Similar products are found below :

[589158040000018](#) [MDF7C-18P-2.54DSA\(55\)](#) [FCN-230C068-11](#) [FCN-268F012-G/BD](#) [FCN-268F036-G/BD](#) [FCN-268M012-G/0D](#) [FCN-268M024-G/1D](#) [FCN-723J004/1](#) [MIS-048-01-F-D-DP-K](#) [832-10-034-10-001000](#) [FX4C-80S-1.27DSA](#) [FCN-214Q030-G/0](#) [FCN-234P048-G/0](#) [FCN-235D050-G/C](#) [210-93-314-41-105000](#) [2-22603-0](#) [MDF7-40DP-2.54DSA\(55\)](#) [AXG720047](#) [MIT-114-03-F-D-K](#) [55323-1519](#) [DF33-2P-3.3DSA\(24\)](#) [YFT-20-05-H-03-SB-K](#) [503308-3040](#) [026-6203-PDB](#) [027-6203-PDB](#) [069159702701000](#) [10123981-102LF](#) [101A10019X](#) [55650-0588-C](#) [68682-310LF](#) [68684-306](#) [75140-7012](#) [87471-650](#) [YTW-30-07-H-Q-410-140](#) [FCN-268F024-G0D](#) [10124054-515LF](#) [68685-603](#) [8-1616154-3](#) [MIS-019-01-F-D](#) [FCN-268M024-G/3D](#) [FCN-268M036-G/BD](#) [20021832-06016C1LF](#) [KX15-20KLDL-E1000E](#) [AXE810124](#) [FCN-214J100-G/0](#) [FCN-230C068-E/S](#) [AXE812124](#) [AXE816124](#) [AXE720127](#) [354184](#)