

Jul.1.2019 Copyright 2019 HIROSE ELECTRIC CO., LTD. All Rights Reserved.  
 In case of consideration for using Automotive equipment / device which demand high reliability, kindly contact our sales window correspondents.

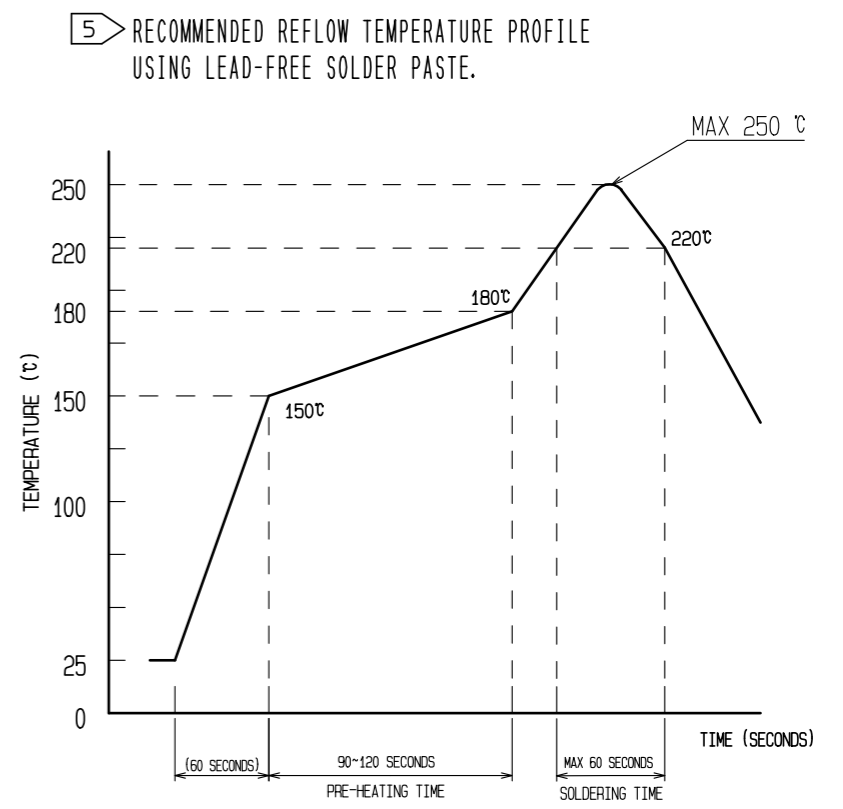
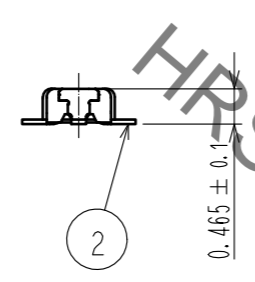
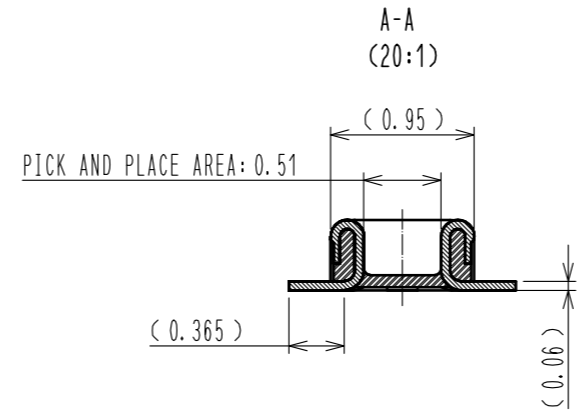
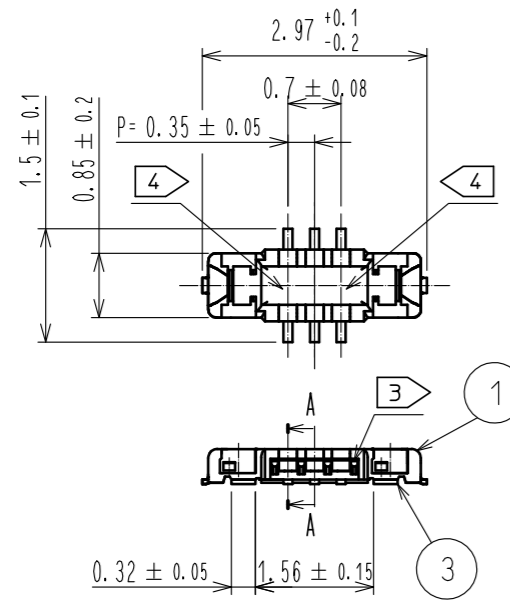

REFLOW METHOD: IR REFLOW  
 NUMBER OF REFLOW CYCLES: 2 CYCLES MAX.  
 1) REFLOW TIME  
 DURATION ABOVE 220°C: 60 SEC MAX.  
 (PEAK TEMPERATURE: 250°C MAX)  
 2) PRE-HEAT TIME  
 PRE-HEAT TEMPERATURE (MIN): 150°C  
 PRE-HEAT TEMPERATURE (MAX): 180°C  
 PRE-HEAT TIME: 90-120 SEC.

THIS TEMPERATURE PROFILE IS PER THE CONDITIONS SHOWN ABOVE. ADDITIONAL FACTORS, SUCH AS SOLDER PASTE TYPE, PCB SIZE AND OTHER MOUNTED COMPONENTS COULD AFFECT THE PROFILE. THEREFORE, A THOROUGH EVALUATION OF MOUNTING COONDITION IS REQUIRED PRIOR TO PRODUCTION. TEMPERATURE IS MEASURED AT CONTACT LEAD.  
 6. PLEASE CONTACT US IN CASE YOU WILL MAKE DIFFERENT SETTINGS FROM OUR RECOMMENDATION.  
 7. THIS PRODUCT SATISFIES HALOGEN FREE REQUIREMENTS DEFINED AS 900ppm MAXIMUM CHLORINE, 900ppm MAXIMUM BROMINE, AND 1500ppm MAXIMUM TOTAL OF CHLORINE AND BROMINE.  
 8. THIS PRODUCT COMPLY WITH ROHS.

NOTE 1. ALL LEAD CO-PLANARITY SHALL BE 0.08mm MAX.  
 2 CONTACT PLATING SPECIFICATIONS  
 CONTACT AREA : GOLD 0.05 μm MIN  
 SMT LEAD : GOLD 0.05 μm MIN  
 UNDER PLATING : NICKEL 1 μm MIN  
 (SURFACE : SEALING)  
 3 A PART OF THE WALL COULD BE NOTCHED.  
 4 CAV No. EXISTS IN THE INDICATED POSITION.

◆ RECOMMENDED PCB LAYOUT

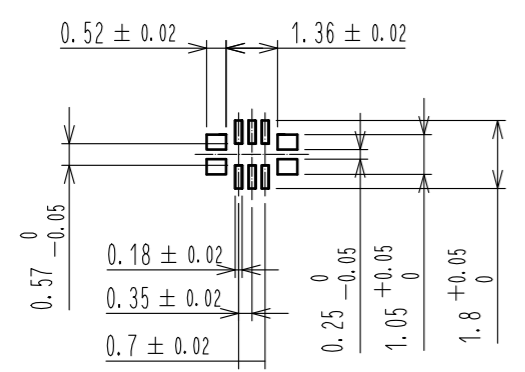

◆ RECOMMENDED METAL MASK DIMENSIONS  
METAL MASK THICKNESS : 80 μm

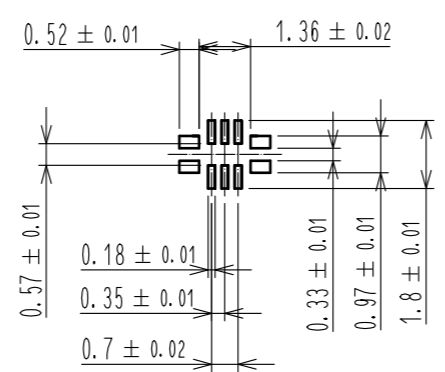

◆ RECOMMENDED PCB LAYOUT (ALLOCATION AROUND CONNECTOR)

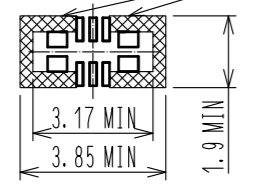

NO COMPONENTS, AND NO CONDUCTIVE TRACES AND VIAS FOR OTHER COMPONENTS, WHICH WOULD INTERFERE WITH RECEPTACLE

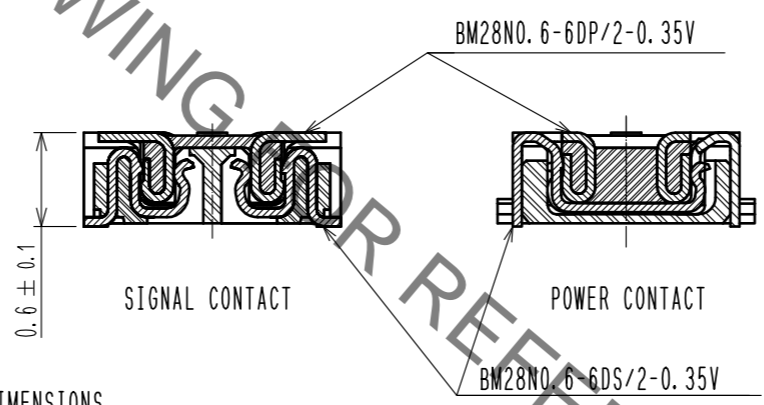

4	PS	CLEAR(EMBOSSED CARRIER TAPE)					
3	COPPER ALLOY	2	7	PS	CLEAR (REINFORCEMENT COLLAR)		
2	COPPER ALLOY	2	6	PS	BLACK (PLASTIC REEL)		
1	LCP	UL94 V-0, BLACK	5	POLYESTER	CLEAR (COVER TAPE)		
NO.	MATERIAL	FINISH, REMARKS	NO.	MATERIAL	FINISH, REMARKS		
UNITS mm		SCALE 10:1	COUNT	DESCRIPTION OF REVISIONS	DESIGNED	CHECKED	DATE
<b>HRS</b> HIROSE ELECTRIC CO., LTD.		APPROVED : MO. ISHIDA	17.05.23	DRAWING NO. EDC-368278-53-00			
		CHECED : TS. MIYAZAKI	17.05.23	PART NO. BM28NO. 6-6DP/2-0.35V(53)			
		DESIGNED : RT. SHIMIZU	17.05.23	CODE NO. CL673-5059-0-53			
		DRAWN : SN. NUMAZAKI	17.05.23	1/2			

Jul.1.2019 Copyright 2019 HIROSE ELECTRIC CO., LTD. All Rights Reserved.  
 In case of consideration for using Automotive equipment / device which demand high reliability, kindly contact our sales window correspondents.

# EMBOSED CARRIER TAPE PACKAGING (5:1)

# STYLE AND DIMENSION OF REEL (FREE)

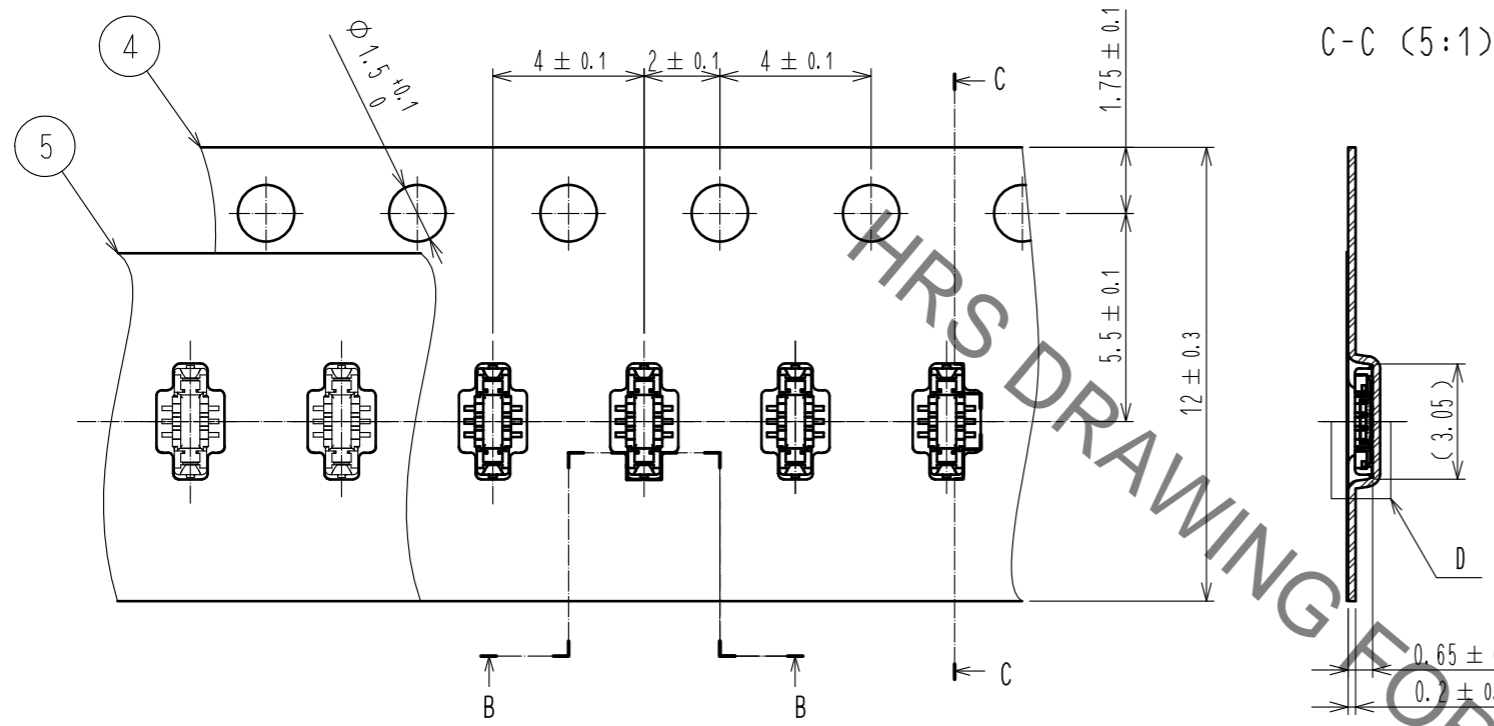

B-B (5:1)

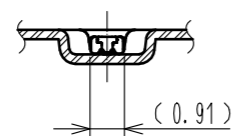

DIRECTION OF UNREELING

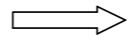

C-C (5:1)

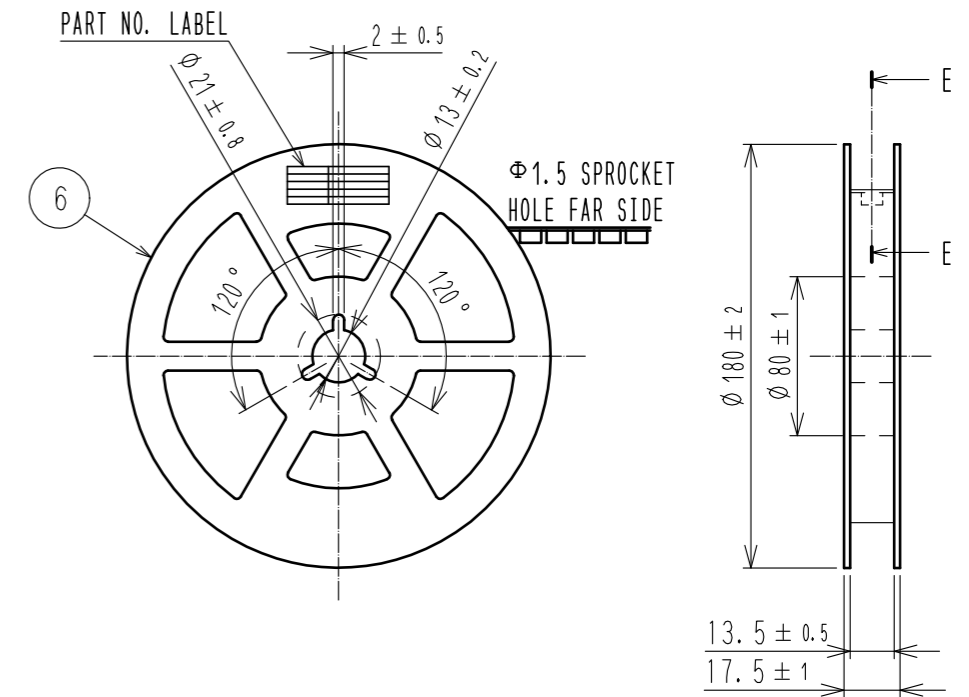
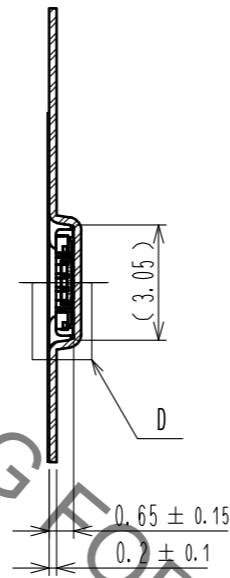

E-E (FREE)

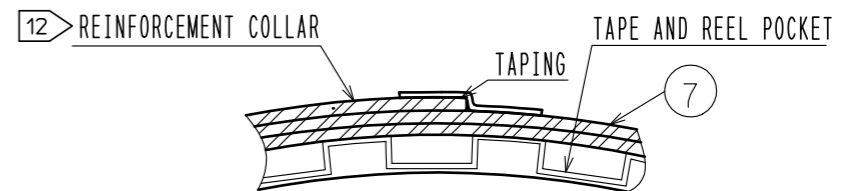

## DETAIL OF PART NO. LABEL

製造年月日	** ** *
製品コード	CL0673-****-**
製品名	BM28NO. 6-**
数量	1,000
納入者	ヒロセ電機(株)

DATA OF MANUFACTURED  
 CODE NO.  
 PART NO.  
 QUANTITY  
 SUPPLIER

- 9 . PER REEL 1,000 CONNECTORS.
- 10 . THE DIMENSIONS IN PARENTHESES ARE FOR REFERENCE.
- 11 . REFER TO JIS C 0806 (PACKAGING OF COMPONENTS FOR AUTOMATIC HANDLING)
- 12 . AFTER PACKAGING, ROLL 2 METERS OF THE REINFORCEMENT COLLAR TO OUTER CIRCUMFERENCE OF TAPE AND REEL POCKET. AND TAPE DOWN AT THE END THE COLLAR.

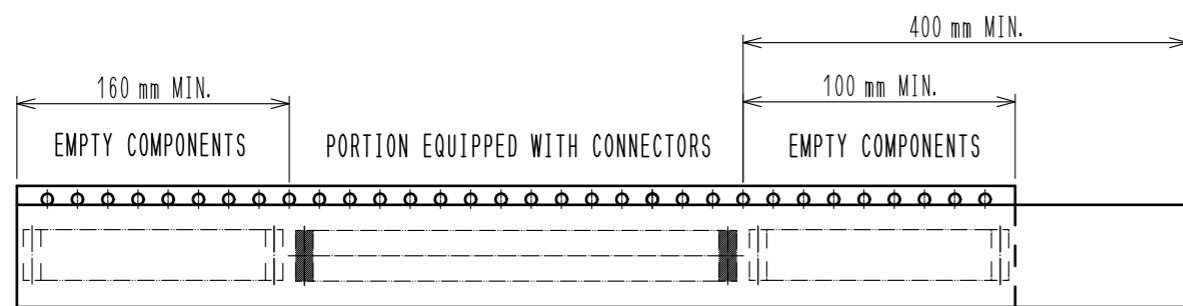

TRAILER

11 TAPING(FREE)

LEADER

D (10:1)

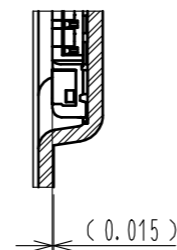

DRAWING NO.	EDC-368278-53-00
PART NO.	BM28NO. 6-6DP/2-0.35V(53)
CODE NO.	CL673-5059-0-53

## X-ON Electronics

Largest Supplier of Electrical and Electronic Components

*Click to view similar products for [Board to Board & Mezzanine Connectors](#) category:*

*Click to view products by [Hirose](#) manufacturer:*

Other Similar products are found below :

[589158040000018](#) [MDF7C-18P-2.54DSA\(55\)](#) [FCN-230C068-11](#) [FCN-268F012-G/BD](#) [FCN-268F036-G/BD](#) [FCN-268M012-G/0D](#) [FCN-268M024-G/1D](#) [FCN-723J004/1](#) [MIS-048-01-F-D-DP-K](#) [832-10-034-10-001000](#) [FX4C-80S-1.27DSA](#) [FCN-214Q030-G/0](#) [FCN-234P048-G/0](#) [FCN-235D050-G/C](#) [210-93-314-41-105000](#) [2-22603-0](#) [MDF7-40DP-2.54DSA\(55\)](#) [AXG720047](#) [MIT-114-03-F-D-K](#) [55323-1519](#) [DF33-2P-3.3DSA\(24\)](#) [YFT-20-05-H-03-SB-K](#) [503308-3040](#) [026-6203-PDB](#) [027-6203-PDB](#) [069159702701000](#) [10123981-102LF](#) [101A10019X](#) [55650-0588-C](#) [68682-310LF](#) [68684-306](#) [75140-7012](#) [87471-650](#) [YTW-30-07-H-Q-410-140](#) [FCN-268F024-G0D](#) [10124054-515LF](#) [68685-603](#) [8-1616154-3](#) [MIS-019-01-F-D](#) [FCN-268M024-G/3D](#) [FCN-268M036-G/BD](#) [20021832-06016C1LF](#) [KX15-20KLDL-E1000E](#) [AXE810124](#) [FCN-214J100-G/0](#) [FCN-230C068-E/S](#) [AXE812124](#) [AXE816124](#) [AXE720127](#) [354184](#)