

DRAWING FOR REFERENCE: This is subject to change without notice  
08/11/2012

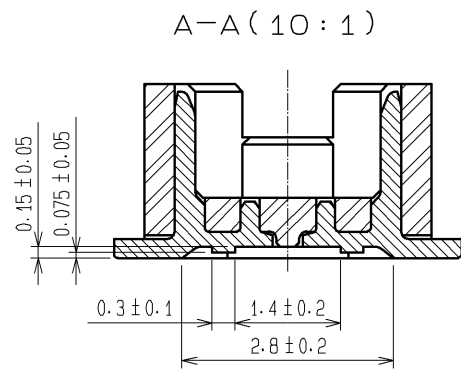

RECOMMEND METAL MASK PATTERN (10:1)

RECOMMENDED LAND PATTERN (10:1)

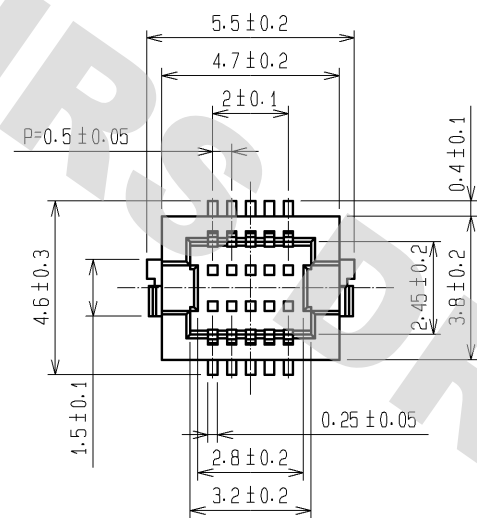
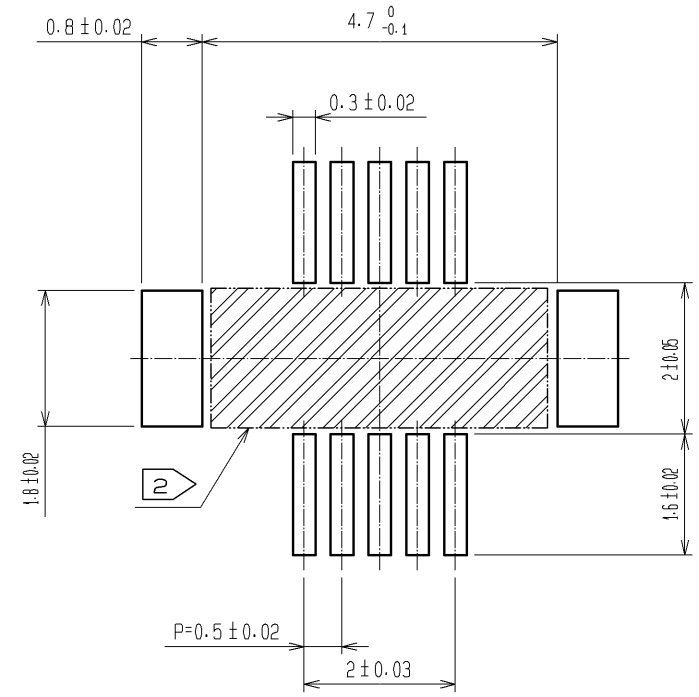
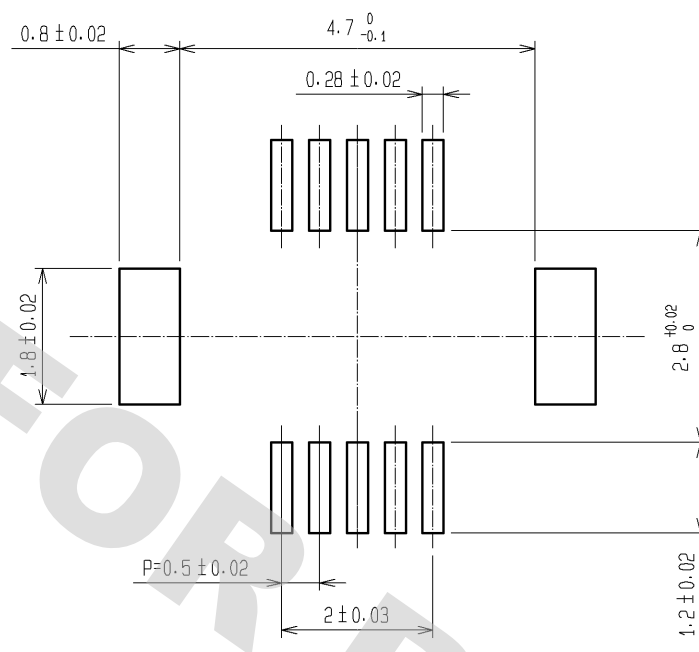

RECOMMENDED THICKNESS OF SOLDER PASTE : 120 μm

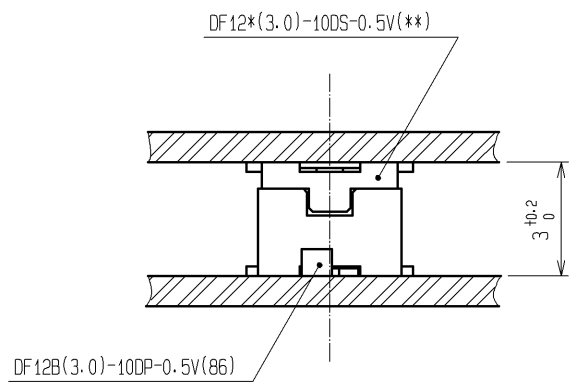
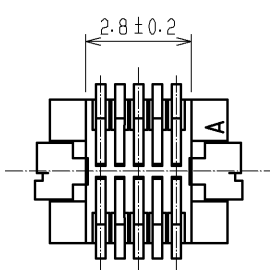
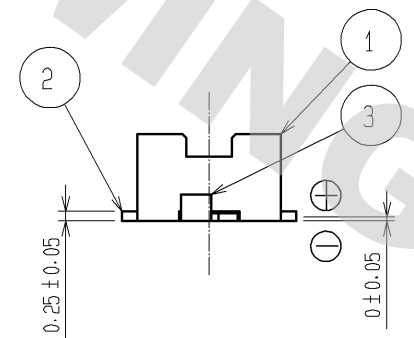
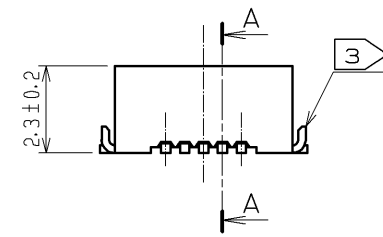

- NOTES 1 : LEAD CO-PLANARITY SHALL BE 0.08 mm MAX.  
 2 : IF THERE IS PATTERN ON PART, THERE IS A POSSIBILITY THAT IT WILL MAKE CONTACT WITH THE LEADS.  
 3 : REINFORCED METAL FITTINGS AS FOLLOWS.

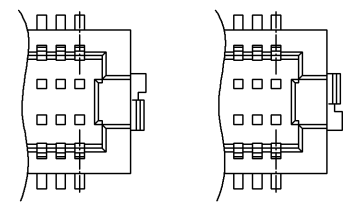

2	PHOSPHOR BRONZE	CONTACT AREA:GOLD PLATED 0.2μm min LEAD AREA:GOLD PLATED 0.015μm min OTHERS(UNDER PLATING):NICKEL PLATED 2μm min	6	PS	BLACK (PLASTIC REEL)
1	POLYAMIDE	UL94V-0, NATURAL (BEIGE)	5	POLYESTER	CLEAR (COVER TAPE)
			4	PS	CLEAR (EMBOSSD CARRIER TAPE)
			3	BRASS	TIN PLATED 2μm min (UNDER PLATING):NICKEL 1μm min
NO.	MATERIAL	FINISH . REMARKS	NO.	MATERIAL	FINISH . REMARKS
UNITS mm		SCALE 5 : 1	COUNT 	DESIGNED	CHECKED
<b>HRS</b> HIROSE ELECTRIC CO., LTD.		APPROVED : KH. IKEDA 08.05.28	DRAWING NO. EDC3-162969-86		
		CHECED : TS. MIYAZAKI 08.05.28	PART NO. DF12B(3.0)-10DP-0.5V(86)		
		DESIGNED : TY. YAMASAKI 08.05.23	CODE NO. CL537-0756-4-86		
		DRAWN : TY. YAMASAKI 08.05.23	DATE		

DRAWING FOR REFERENCE: This is subject to change without notice  
08/11/2012

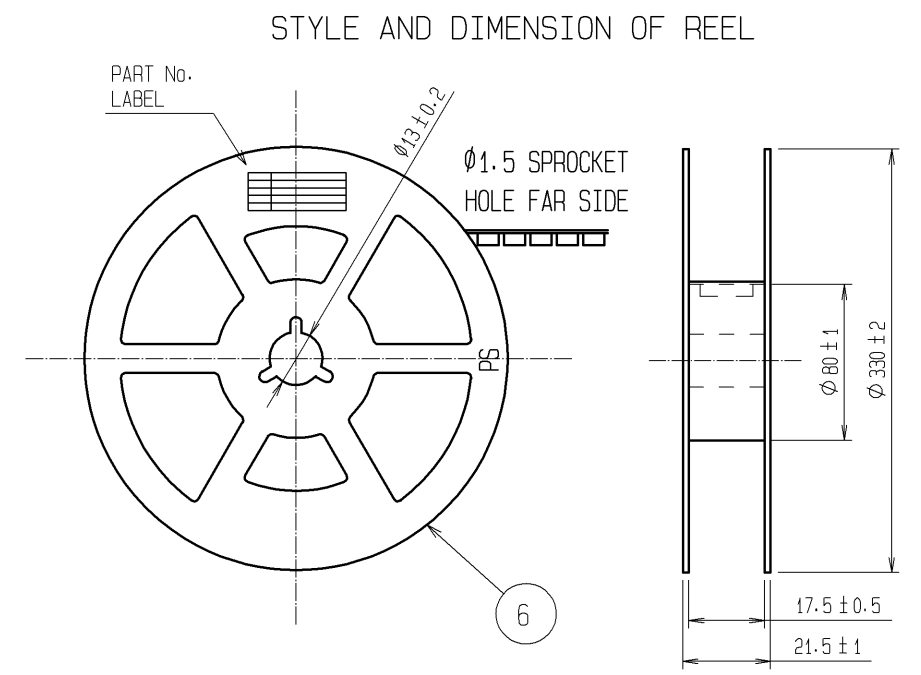
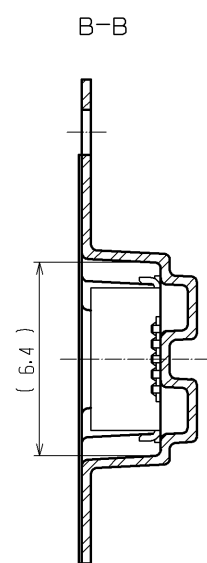
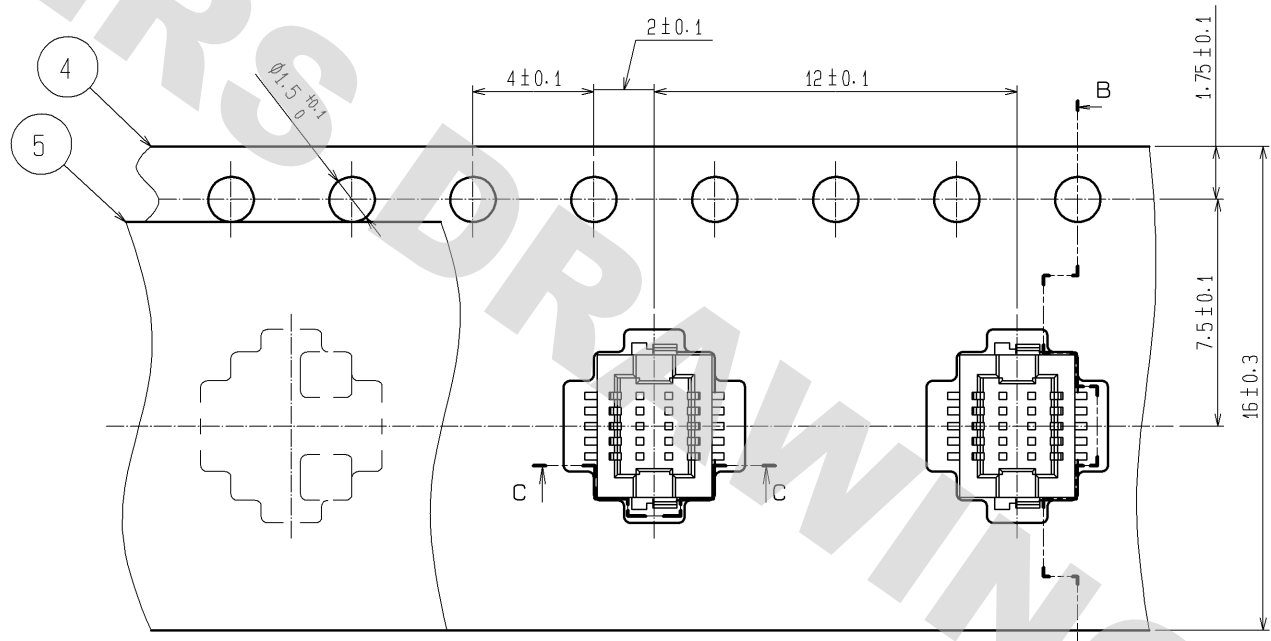

DIRECTION OF UNREELING →

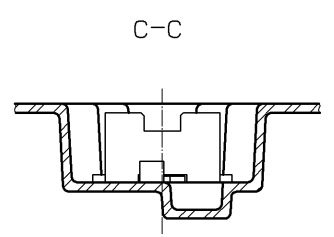

SUPPLIER  
QUANTITY  
PART No.  
CODE No.  
DATE OF MANUFACTURED

DETAIL OF PART No. LABEL

生産月日	年 月 日
図番	CL537-0756-4-86
品名	DF12B(3.0)-10DP-0.5V(86)
納入数量	1000K0
納入者	ヒロセ電機(株)

- NOTES 4 : 1 REEL 1000 CONNECTORS.  
 5 : AT THE BEGINNING OF THE REEL, 30 COMPONENTS SHALL BE EMPTY.  
 AT THE END OF THE REEL, 20 COMPONENTS SHALL BE EMPTY.  
 6 : PEEL FORCE REFERS TO JIS C 0806.  
 7 : THE REEL IS PACKED WITH A POLYETHYLENE MATERIAL, TOGETHER WITH A DRYING AGENT.

<b>HRS</b>	DRAWING NO.	EDC3-162969-86
	PART NO.	DF12B(3.0)-10DP-0.5V(86)
	CODE NO.	CL537-0756-4-86
		△ 2/2

## X-ON Electronics

Largest Supplier of Electrical and Electronic Components

*Click to view similar products for [Board to Board & Mezzanine Connectors](#) category:*

*Click to view products by [Hirose](#) manufacturer:*

Other Similar products are found below :

[589158040000018](#) [MDF7C-18P-2.54DSA\(55\)](#) [FCN-230C068-11](#) [FCN-268F012-G/BD](#) [FCN-268F036-G/BD](#) [FCN-268M012-G/0D](#) [FCN-268M024-G/1D](#) [FCN-723J004/1](#) [MIS-048-01-F-D-DP-K](#) [832-10-034-10-001000](#) [FX4C-80S-1.27DSA](#) [FCN-214Q030-G/0](#) [FCN-234P048-G/0](#) [FCN-235D050-G/C](#) [210-93-314-41-105000](#) [2-22603-0](#) [MDF7-40DP-2.54DSA\(55\)](#) [AXG720047](#) [MIT-114-03-F-D-K](#) [55323-1519](#) [DF33-2P-3.3DSA\(24\)](#) [YFT-20-05-H-03-SB-K](#) [503308-3040](#) [026-6203-PDB](#) [027-6203-PDB](#) [069159702701000](#) [10123981-102LF](#) [101A10019X](#) [55650-0588-C](#) [68682-310LF](#) [68684-306](#) [75140-7012](#) [87471-650](#) [YTW-30-07-H-Q-410-140](#) [FCN-268F024-G0D](#) [10124054-515LF](#) [68685-603](#) [8-1616154-3](#) [MIS-019-01-F-D](#) [FCN-268M024-G/3D](#) [FCN-268M036-G/BD](#) [20021832-06016C1LF](#) [KX15-20KLDL-E1000E](#) [AXE810124](#) [FCN-214J100-G/0](#) [FCN-230C068-E/S](#) [AXE812124](#) [AXE816124](#) [AXE720127](#) [354184](#)