

Feb.1.2018 Copyright 2018 HIROSE ELECTRIC CO., LTD. All Rights Reserved.

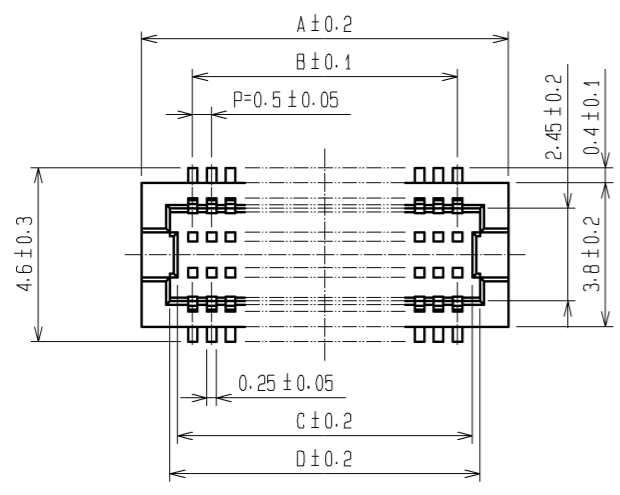

G-G (10:1)

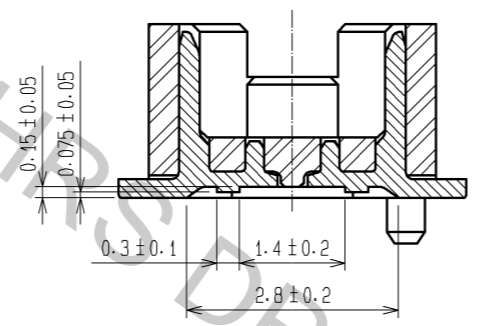

CODE No.	CONTACT	A	B	C	D	E	F
CL537-0791-5-81	10	4.7	2.0	2.8	3.2	4.1	2.8
CL537-0920-6-81	14	5.7	3.0	3.8	4.2	5.1	3.8
CL537-0793-0-81	20	7.2	4.5	5.3	5.7	6.6	5.3
CL537-0795-6-81	30	9.7	7.0	7.8	8.2	9.1	7.8
CL537-0802-0-81	32	10.2	7.5	8.3	8.7	9.6	8.3
CL537-0796-9-81	36	11.2	8.5	9.3	9.7	10.6	9.3
CL537-0797-1-81	40	12.2	9.5	10.3	10.7	11.6	10.3
CL537-0799-7-81	50	14.7	12.0	12.8	13.2	14.1	12.8
CL537-0801-7-81	60	17.2	14.5	15.3	15.7	16.6	15.3
CL537-0803-2-81	80	22.2	19.5	20.3	20.7	21.6	20.3

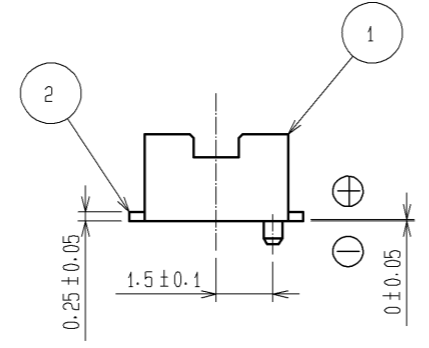
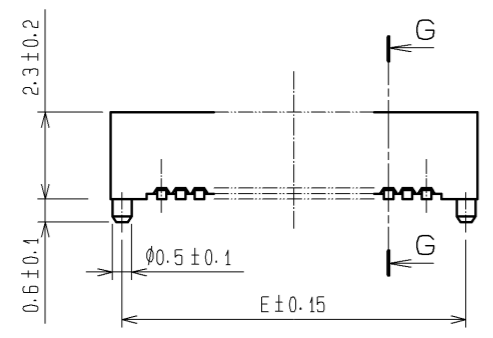

RECOMMEND METAL MASK PATTERN (10:1)

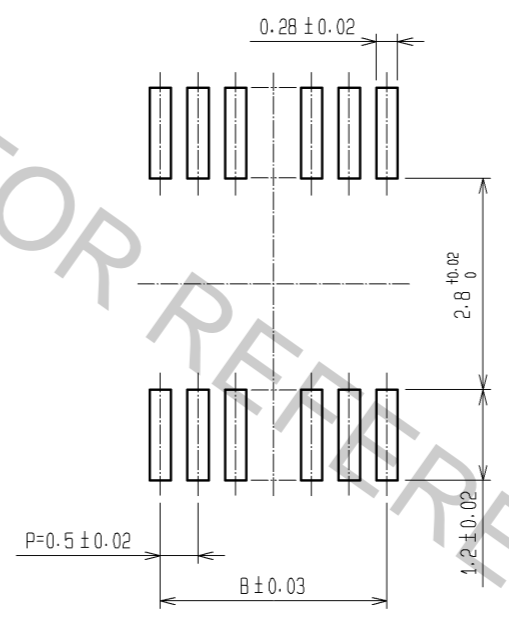

RECOMMENDED LAND PATTERN (10:1)

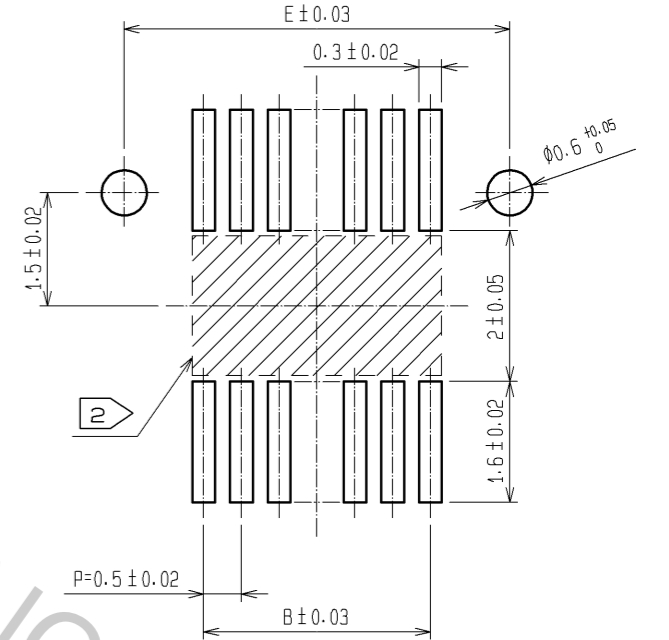

RECOMMENDED THICKNESS OF METAL MASK : 120 #m

RECOMMENDED THICKNESS OF SOLDER PASTE : 120 #m

NOTES 1 LEAD CO-PLANARITY SHALL BE 0.08 mm MAX.  
 2 IF THERE IS PATTERN ON PART, THERE IS A POSSIBILITY THAT IT WILL MAKE CONTACT WITH THE LEADS.

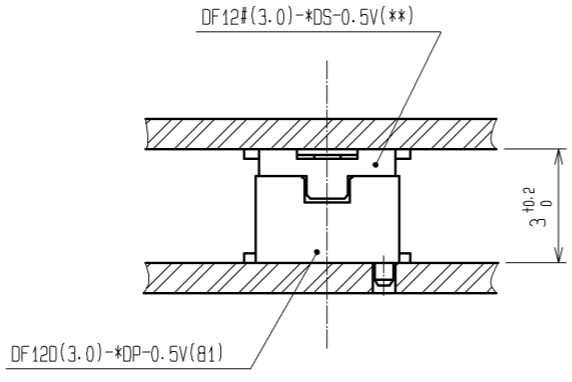

NO.	MATERIAL	FINISH	REMARKS	NO.	MATERIAL	FINISH	REMARKS
2	PHOSPHOR BRONZE		CONTACT AREA:GOLD PLATED 0.2#m min LEAD AREA:GOLD PLATED 0.015#m min OTHERS(UNDER PLATING):NICKEL PLATED 2#m min	6	PS		CLEAR (REINFORCEMENT COLLAR)
				5	PS		BLACK (PLASTIC REEL)
				4	POLYESTER		CLEAR (COVER TAPE)
1	POLYAMIDE		UL94V-0, NATURAL (BEIGE)	3	PS		CLEAR (EMBOSSED CARRIER TAPE)

UNITS	SCALE	COUNT	DESCRIPTION OF REVISIONS	DESIGNED	CHECKED	DATE
mm	5:1	△				

APPROVED : KH. IKEDA	13.08.19	DRAWING NO.	EDC3-163508-77
CHECED : YH. MICHIDA	13.08.08	PART NO.	DF12D(3.0)-*DP-0.5V(81)
DESIGNED : YN. SAKAMOTO	13.08.08	CODE NO.	CL537
DRAWN : KR. AJITO	13.08.08		

Feb.1.2018 Copyright 2018 HIROSE ELECTRIC CO., LTD. All Rights Reserved.

STYLE AND DIMENTION OF REEL (FREE)

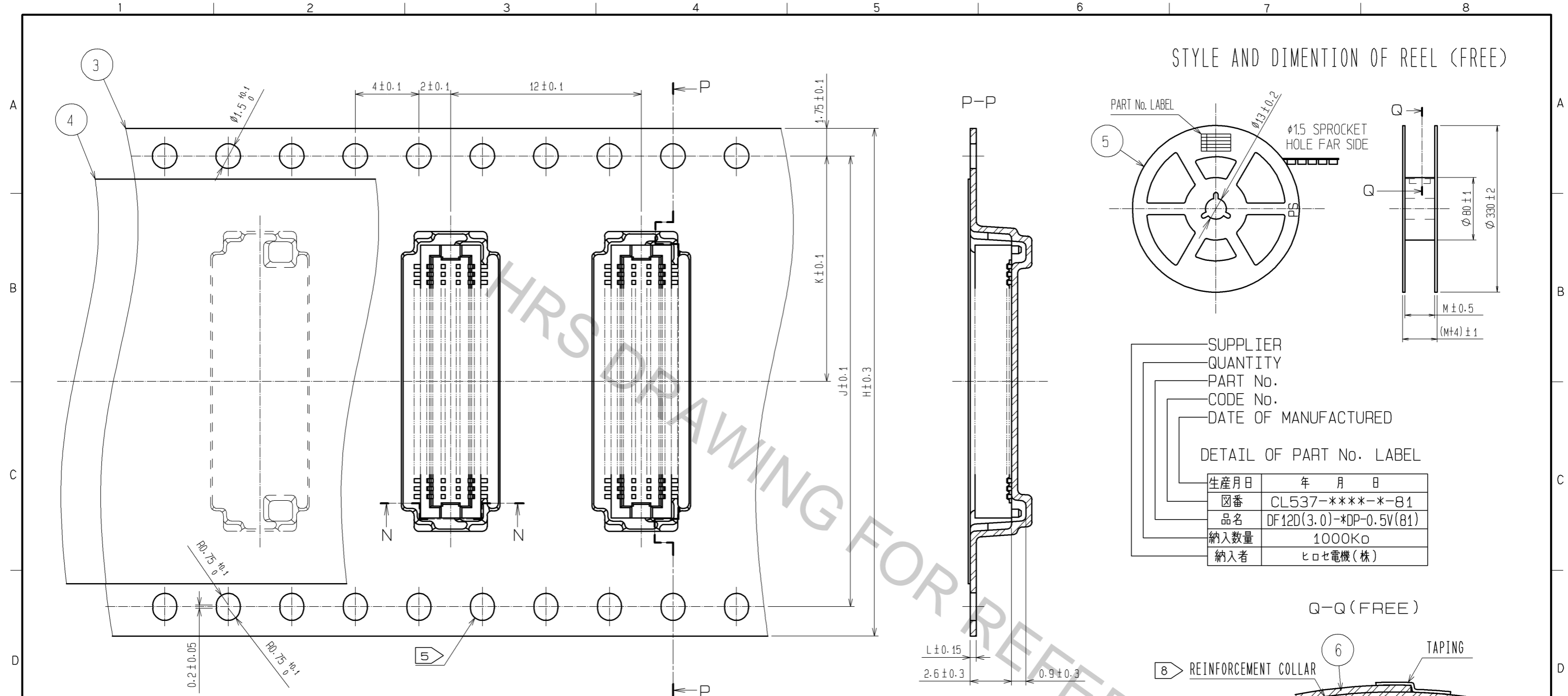

SUPPLIER  
QUANTITY  
PART No.  
CODE No.  
DATE OF MANUFACTURED

DETAIL OF PART No. LABEL

生産月日	年 月 日
図番	CL537-****-*-81
品名	DF12D(3.0)-*DP-0.5V(81)
納入数量	1000K $\phi$
納入者	ヒロセ電機(株)

DIRECTION OF UNREELING

CODE No.	CONTACT	H	J	K	L	M
CL537-0791-5-81	10	16	-	7.5	0.30	17.5
CL537-0920-6-81	14	16	-	7.5	0.30	17.5
CL537-0793-0-81	20	16	-	7.5	0.38	17.5
CL537-0795-6-81	30	24	-	11.5	0.38	25.5
CL537-0802-0-81	32	24	-	11.5	0.30	25.5
CL537-0796-9-81	36	24	-	11.5	0.38	25.5
CL537-0797-1-81	40	24	-	11.5	0.38	25.5
CL537-0799-7-81	50	24	-	11.5	0.38	25.5
CL537-0801-7-81	60	32	28.4	14.2	0.38	33.5
CL537-0803-2-81	80	44	40.4	20.2	0.38	45.5

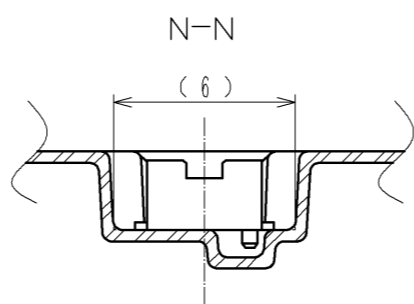

- NOTES 3 1 REEL 1000 CONNECTORS.  
 4 AT THE BEGINNING OF THE REEL, 30 COMPONENTS SHALL BE EMPTY.  
 AT THE END OF THE REEL, 20 COMPONENTS SHALL BE EMPTY.  
 5 WHEN THE TAPE WIDTH IS 32 mm OR 44mm, SPROCKET HOLES SHALL BE SET ON BOTH SIDE OF REEL AS SHOWN ON THIS DRAWING.  
 6 PEEL FORCE REFERS TO JIS C 0806. (IEC 60286-3)  
 7 THE REEL IS PACKED WITH A POLYETHYLENE MATERIAL, TOGETHER WITH A DRYING AGENT.  
 8 AFTER PACKING, ROLL 2 METERS OF THE REINFORCEMENT COLLAR TO OUTER CIRCUMFERENCE OF TAPE AND REEL POCKET, AND TAPE DOWN AT THE END THE COLLAR.

<b>HRS</b>	DRAWING NO.	EDC3-163508-77
	PART NO.	DF12D(3.0)-*DP-0.5V(81)
	CODE NO.	CL537
		$\triangle$ 2/2

## X-ON Electronics

Largest Supplier of Electrical and Electronic Components

*Click to view similar products for [Board to Board & Mezzanine Connectors](#) category:*

*Click to view products by [Hirose](#) manufacturer:*

Other Similar products are found below :

[589158040000018](#) [MDF7C-18P-2.54DSA\(55\)](#) [FCN-230C068-11](#) [FCN-268F012-G/BD](#) [FCN-268F036-G/BD](#) [FCN-268M012-G/0D](#) [FCN-268M024-G/1D](#) [FCN-723J004/1](#) [MIS-048-01-F-D-DP-K](#) [832-10-034-10-001000](#) [FX4C-80S-1.27DSA](#) [FCN-214Q030-G/0](#) [FCN-234P048-G/0](#) [FCN-235D050-G/C](#) [210-93-314-41-105000](#) [2-22603-0](#) [MDF7-40DP-2.54DSA\(55\)](#) [AXG720047](#) [MIT-114-03-F-D-K](#) [55323-1519](#) [DF33-2P-3.3DSA\(24\)](#) [YFT-20-05-H-03-SB-K](#) [503308-3040](#) [026-6203-PDB](#) [027-6203-PDB](#) [069159702701000](#) [10123981-102LF](#) [101A10019X](#) [55650-0588-C](#) [68682-310LF](#) [68684-306](#) [75140-7012](#) [87471-650](#) [YTW-30-07-H-Q-410-140](#) [FCN-268F024-G0D](#) [10124054-515LF](#) [68685-603](#) [8-1616154-3](#) [MIS-019-01-F-D](#) [FCN-268M024-G/3D](#) [FCN-268M036-G/BD](#) [20021832-06016C1LF](#) [KX15-20KLDL-E1000E](#) [AXE810124](#) [FCN-214J100-G/0](#) [FCN-230C068-E/S](#) [AXE812124](#) [AXE816124](#) [AXE720127](#) [354184](#)