

0.5mm Pitch SMT Board-to-Board Connector

DF12N Series

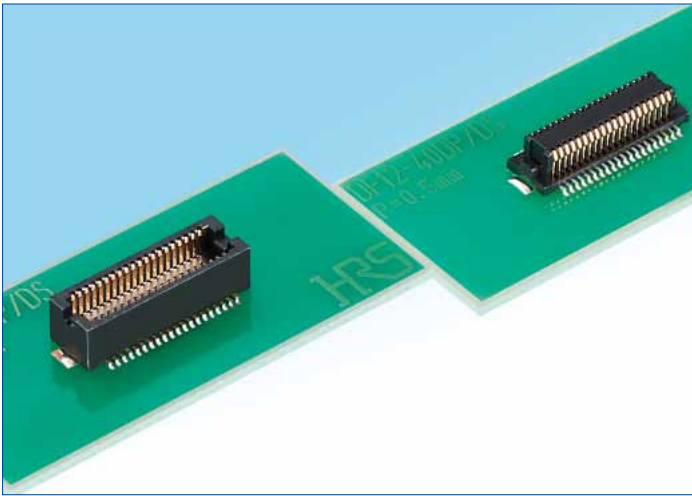

Correspond to automatic mounting

The vacuum pick-up area secures the automatic mounting machine for pick and place.

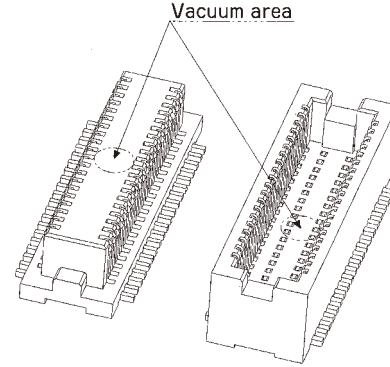
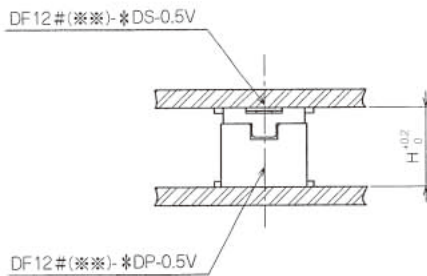

Fig.1

Features

1. Broad Variations of Stacking Height

In addition to 0.5mm pitch ultra-miniature size connector, the stacking height of 3mm, 3.5mm, 4mm, and 5mm are provided.



Header/Receptacle	DF12#(3.0)-*DS-0.5V Combination stacking height	DF12#-*DS-0.5V Combination stacking height
DF12#(3.0)-*DP-0.5V	3.0	—
DF12#(3.5)-*DP-0.5V	—	3.5
DF12#(4.0)-*DP-0.5V	—	4.0
DF12#(5.0)-*DP-0.5V	—	5.0

Note 1 : (**) of the product name DF12# (**) indicates the stacking height.

Note 2 : The stacking height doesn't include the soldering paste thickness.

[Stacking Height Variation]

Stacking Height		3.0mm	3.5mm	4.0mm	5.0mm
Number of Contacts	10 contacts	○	—	—	—
	14 contacts	○	—	—	—
	20 contacts	○	○	○	○
	30 contacts	○	○	○	○
	32 contacts	○	—	○	—
	36 contacts	○	○	○	○
	40 contacts	○	○	○	○
	50 contacts	○	○	○	○
	60 contacts	○	○	○	○
80 contacts	○	—	—	—	

2. Corresponding to Automatic Mounting

The connector has the vacuum pick-up area to enable automatic mounting with the embossed tape packaging. (Fig.1)

3. Metal Fitting Available

The product including the metal fitting to prevent solder peeling is provided, considering the mounting on FPC.

Product Specifications

Ratings	Current rating	0.3A	Operating Temperature Range	-55 to +125°C (Note 1)	Storage Temperature Range	-10 to +60°C (Note 2)
	Voltage rating	50V AC	Operating Humidity Range	40 to 80%	Storage Humidity Range	40 to 70% (Note 2)

Items	Specifications	Conditions
1. Insulation Resistance	500MΩ min.	100V DC
2. Withstanding voltage	No flashover or insulation breakdown.	150V AC / 1minute
3. Contact Resistance	50mΩ max.	20mV AC or less 1kHz, 1mA.
4. Vibration	No electrical discontinuity of 1μs or more	Frequency : 10 to 55 Hz, single amplitude of 0.75mm, 2 hours in each of the 3 directions.
5. Humidity (Steady state)	Contact resistance : 50mΩ max. Insulation resistance : 500MΩ min	96 hours at temperature of 40±2°C and humidity of 90% to 95%
6. Temperature Cycle	Contact resistance : 50mΩ max. Insulation resistance : 500MΩ min	(-65°C : 30 minutes 5 to 35°C : 3 minutes 125°C : 30 minutes 5 to 35°C : 3 minutes) 5 cycles
7. Durability (Mating/un-mating)	Contact resistance : 50mΩ max.	50 cycles
8. Resistance to Soldering heat	No deformation of components affecting performance.	Reflow : At the recommended temperature profile
		Manual soldering : 350°C for 3 seconds

Note 1 : Includes temperature rise caused by current flow.

Note 2 : The term "storage" refers to products stored for long period of time prior to mounting and use. Operating Temperature Range and Humidity range covers non conducting condition of installed connectors in storage, shipment or during transportation.

Materials / Finish

Product	Part	Material	Finish	Remarks
Receptacle/Header	Insulator	Polyamide	Black	UL94V-0
	Contact	Phosphor copper	Gold plated	—
	Fitting	Brass	Tin plated	—

Product Number Structure

Refer to the chart below when determining the product specifications from the product number.

Please select from the product numbers listed in this catalog when placing orders.

Receptacle

DF12 # (※※) - * DS - 0.5 V ()**

① ② ③ ④ ⑤ ⑥ ⑦ ⑧

① Series Name : DF12 ② Type <table border="1" style="margin-left: 20px;"> <thead> <tr> <th colspan="2">Fitting</th> </tr> </thead> <tbody> <tr> <td>NB</td> <td>○</td> </tr> <tr> <td>NC</td> <td>×</td> </tr> </tbody> </table>	Fitting		NB	○	NC	×	③ Stacking height 3.0 : 3.0mm Blank : 3.5 to 5.0mm	⑥ Contact Pitch : 0.5mm ⑦ Contact Style V : Straight SMT
	Fitting							
	NB	○						
NC	×							
④ Number of Contacts : 10, 14, 20, 30, 32, 36, 40, 50, 60, 80	⑤ Connector Type DS : Double-row receptacle	⑧ Packaging Type (51) : Embossed tape packaging (1,000pcs/reel)						

Header

DF12 # (※※) - * DP - 0.5 V ()**

① ② ③ ④ ⑤ ⑥ ⑦ ⑧

① Series Name : DF12 ② Type <table border="1" style="margin-left: 20px;"> <thead> <tr> <th colspan="2">Fitting</th> </tr> </thead> <tbody> <tr> <td>NB</td> <td>○</td> </tr> <tr> <td>NC</td> <td>×</td> </tr> </tbody> </table>	Fitting		NB	○	NC	×	③ Stacking height <table border="1" style="margin-left: 20px;"> <thead> <tr> <th>Indication</th> <th>Stacking Height</th> </tr> </thead> <tbody> <tr> <td>3.0</td> <td>3.0mm</td> </tr> <tr> <td>3.5</td> <td>3.5mm</td> </tr> <tr> <td>4.0</td> <td>4.0mm</td> </tr> <tr> <td>5.0</td> <td>5.0mm</td> </tr> </tbody> </table>	Indication	Stacking Height	3.0	3.0mm	3.5	3.5mm	4.0	4.0mm	5.0	5.0mm	⑤ Connector Type DP : Double-row pin header ⑥ Contact Pitch : 0.5mm ⑦ Contact Style V : Straight SMT
	Fitting																	
	NB	○																
NC	×																	
Indication	Stacking Height																	
3.0	3.0mm																	
3.5	3.5mm																	
4.0	4.0mm																	
5.0	5.0mm																	
④ Number of Contacts : 10, 14, 20, 30, 32, 36, 40, 50, 60, 80		⑧ Packaging Type (51) : Embossed tape packaging (1,000pcs/reel)																

Receptacle Without metal fitting

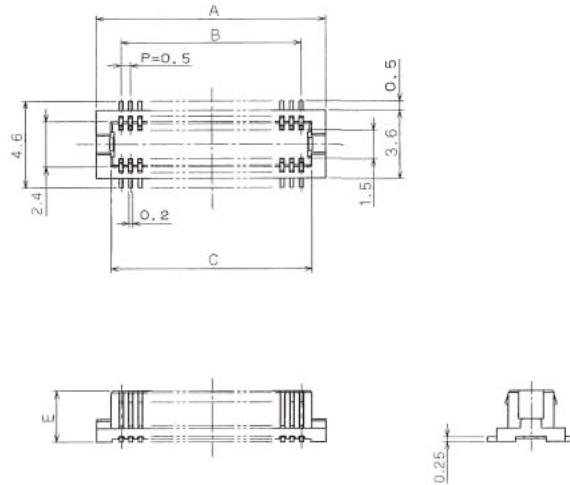
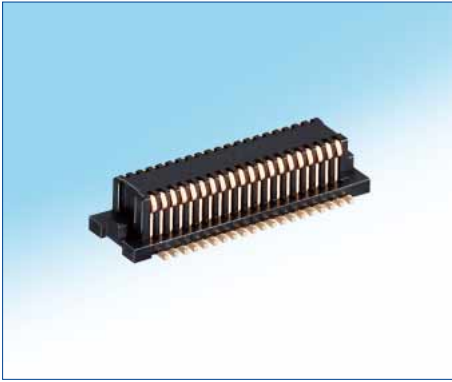

Stacking Height : 3mm Product

Unit : mm

Part No.	HRS No.	No. of Contacts	A	B	C	E	Remarks	RoHS
DF12NC(3.0)-10DS-0.5V(51)	537-0191-0 51	10	4.6	2.0	3.1	2.2	Without metal fitting Without boss	YES
DF12NC(3.0)-14DS-0.5V(51)	537-0192-0 51	14	5.6	3.0	4.1			
DF12NC(3.0)-20DS-0.5V(51)	537-0193-0 51	20	7.1	4.5	5.6			
DF12NC(3.0)-30DS-0.5V(51)	537-0194-0 51	30	9.6	7.0	8.1			
DF12NC(3.0)-32DS-0.5V(51)	537-0195-0 51	32	10.1	7.5	8.6			
DF12NC(3.0)-36DS-0.5V(51)	537-0196-0 51	36	11.1	8.5	9.6			
DF12NC(3.0)-40DS-0.5V(51)	537-0197-0 51	40	12.1	9.5	10.6			
DF12NC(3.0)-50DS-0.5V(51)	537-0198-0 51	50	14.6	12.0	13.1			
DF12NC(3.0)-60DS-0.5V(51)	537-0199-0 51	60	17.1	14.5	15.6			
DF12NC(3.0)-80DS-0.5V(51)	537-0285-0 51	80	22.1	19.5	20.6			

Stacking Height : 3.5 to 5mm Product

Unit : mm

Part No.	HRS No.	No. of Contacts	A	B	C	E	Remarks	RoHS
DF12NC-20DS-0.5V(51)	537-0292-0 51	20	7.1	4.5	5.6	2.7	Without metal fitting	YES
DF12NC-30DS-0.5V(51)	537-0293-0 51	30	9.6	7.0	8.1			
DF12NC-32DS-0.5V(51)	537-0294-0 51	32	10.1	7.5	8.6			
DF12NC-36DS-0.5V(51)	537-0295-0 51	36	11.1	8.5	9.6			
DF12NC-40DS-0.5V(51)	537-0296-0 51	40	12.1	9.5	10.6			
DF12NC-50DS-0.5V(51)	537-0297-0 51	50	14.6	12.0	13.1			
DF12NC-60DS-0.5V(51)	537-0298-0 51	60	17.1	14.5	15.6			

Note : Please order the embossed tape packaging product per reel. (1000 pcs./reel)

■ Receptacle With metal fitting

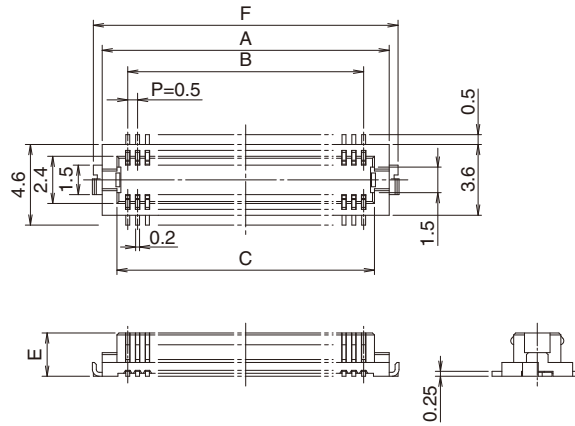
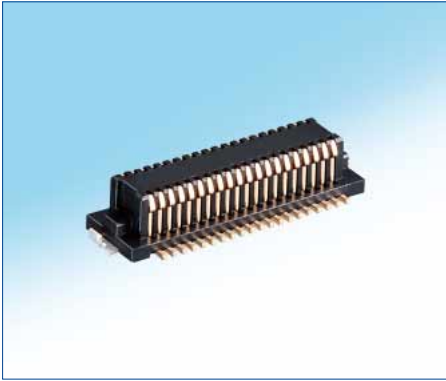

● Stacking Height : 3mm Product

Unit : mm

Part No.	HRS No.	No. of Contacts	A	B	C	E	F	Remarks	RoHS
DF12NB(3.0)-10DS-0.5V(51)	537-0097-0 51	10	4.6	2.0	3.1	2.2	5.6	With metal fitting Without boss	YES
DF12NB(3.0)-14DS-0.5V(51)	537-0098-0 51	14	5.6	3.0	4.1		6.6		
DF12NB(3.0)-20DS-0.5V(51)	537-0099-0 51	20	7.1	4.5	5.6		8.1		
DF12NB(3.0)-30DS-0.5V(51)	537-0185-0 51	30	9.6	7.0	8.1		10.6		
DF12NB(3.0)-32DS-0.5V(51)	537-0186-0 51	32	10.1	7.5	8.6		11.1		
DF12NB(3.0)-36DS-0.5V(51)	537-0187-0 51	36	11.1	8.5	9.6		12.1		
DF12NB(3.0)-40DS-0.5V(51)	537-0188-0 51	40	12.1	9.5	10.6		13.1		
DF12NB(3.0)-50DS-0.5V(51)	537-0189-0 51	50	14.6	12.0	13.1		15.6		
DF12NB(3.0)-60DS-0.5V(51)	537-0190-0 51	60	17.1	14.5	15.6		18.1		
DF12NB(3.0)-80DS-0.5V(51)	537-0095-0 51	80	22.1	19.5	20.6		23.1		

● Stacking Height : 3.5 to 5mm Product

Unit : mm

Part No.	HRS No.	No. of Contacts	A	B	C	E	F	Remarks	RoHS
DF12NB-20DS-0.5V(51)	537-0286-0 51	20	7.1	4.5	5.6	2.7	8.1	With metal fitting	YES
DF12NB-30DS-0.5V(51)	537-0287-0 51	30	9.6	7.0	8.1		10.6		
DF12NB-32DS-0.5V(51)	537-0288-0 51	32	10.1	7.5	8.6		11.1		
DF12NB-36DS-0.5V(51)	537-0289-0 51	36	11.1	8.5	9.6		12.1		
DF12NB-40DS-0.5V(51)	537-0290-0 51	40	12.1	9.5	10.6		13.1		
DF12NB-50DS-0.5V(51)	537-0291-0 51	50	14.6	12.0	13.1		15.6		
DF12NB-60DS-0.5V(51)	537-0096-0 51	60	17.1	14.5	15.6		18.1		

Note : Please order the embossed tape packaging product per reel. (1000 pcs./reel)

Header Without metal fitting

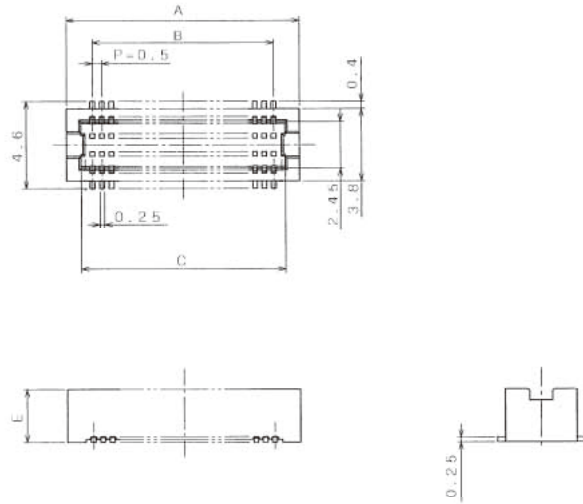

● Stacking Height : 3mm Product

Unit : mm

Part No.	HRS No.	No. of Contacts	A	B	C	E	Remarks	RoHS
DF12NC(3.0)-10DP-0.5V(51)	537-0396-0 51	10	4.7	2.0	3.2	2.3	Without metal fitting	YES
DF12NC(3.0)-14DP-0.5V(51)	537-0397-0 51	14	5.7	3.0	4.2			
DF12NC(3.0)-20DP-0.5V(51)	537-0398-0 51	20	7.2	4.5	5.7			
DF12NC(3.0)-30DP-0.5V(51)	537-0399-0 51	30	9.7	7.0	8.2			
DF12NC(3.0)-32DP-0.5V(51)	537-0487-0 51	32	10.2	7.5	8.7			
DF12NC(3.0)-36DP-0.5V(51)	537-0488-0 51	36	11.2	8.5	9.7			
DF12NC(3.0)-40DP-0.5V(51)	537-0489-0 51	40	12.2	9.5	10.7			
DF12NC(3.0)-50DP-0.5V(51)	537-0490-0 51	50	14.7	12.0	13.2			
DF12NC(3.0)-60DP-0.5V(51)	537-0491-0 51	60	17.2	14.5	15.7			
DF12NC(3.0)-80DP-0.5V(51)	537-0492-0 51	80	22.2	19.5	20.7			

Note : Please order the embossed tape packaging product per reel. (1000 pcs./reel)

Header Without metal fitting

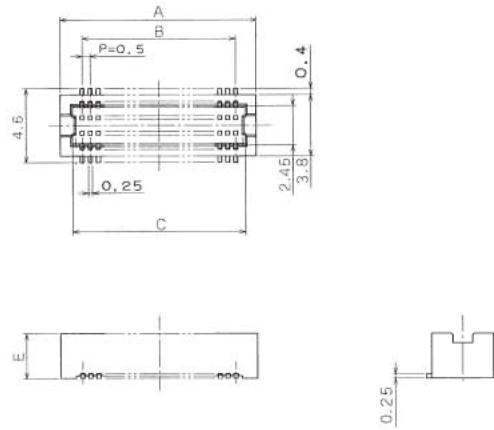

● Stacking Height : 3.5 to 5mm Product

Unit : mm

Part No.	HRS No.	No. of Contacts	A	B	C	E	Remarks	RoHS				
DF12NC(3.5)-20DP-0.5V(51)	537-0499-0 51	20	7.2	4.5	5.7	2.8	Without metal fitting	YES				
DF12NC(3.5)-30DP-0.5V(51)	537-0587-0 51	30	9.7	7.0	8.2							
DF12NC(3.5)-36DP-0.5V(51)	537-0588-0 51	36	11.2	8.5	9.7							
DF12NC(3.5)-40DP-0.5V(51)	537-0589-0 51	40	12.2	9.5	10.7							
DF12NC(3.5)-50DP-0.5V(51)	537-0590-0 51	50	14.7	12.0	13.2							
DF12NC(3.5)-60DP-0.5V(51)	537-0591-0 51	60	17.2	14.5	15.7							
DF12NC(4.0)-20DP-0.5V(51)	537-0599-0 51	20	7.2	4.5	5.7	3.3			Without metal fitting	YES		
DF12NC(4.0)-30DP-0.5V(51)	537-0699-0 51	30	9.7	7.0	8.2							
DF12NC(4.0)-32DP-0.5V(51)	537-0872-0 51	32	10.2	7.5	8.7							
DF12NC(4.0)-36DP-0.5V(51)	537-0873-0 51	36	11.2	8.5	9.7							
DF12NC(4.0)-40DP-0.5V(51)	537-0874-0 51	40	12.2	9.5	10.7							
DF12NC(4.0)-50DP-0.5V(51)	537-0875-0 51	50	14.7	12.0	13.2							
DF12NC(4.0)-60DP-0.5V(51)	537-0876-0 51	60	17.2	14.5	15.7	4.3					Without metal fitting	YES
DF12NC(5.0)-20DP-0.5V(51)	537-0883-0 51	20	7.2	4.5	5.7							
DF12NC(5.0)-30DP-0.5V(51)	537-0884-0 51	30	9.7	7.0	8.2							
DF12NC(5.0)-36DP-0.5V(51)	537-0885-0 51	36	11.2	8.5	9.7							
DF12NC(5.0)-40DP-0.5V(51)	537-0886-0 51	40	12.2	9.5	10.7							
DF12NC(5.0)-50DP-0.5V(51)	537-0887-0 51	50	14.7	12.0	13.2							
DF12NC(5.0)-60DP-0.5V(51)	537-0888-0 51	60	17.2	14.5	15.7							

Note : Please order the embossed tape packaging product per reel. (1000 pcs./reel)

Header With metal fitting

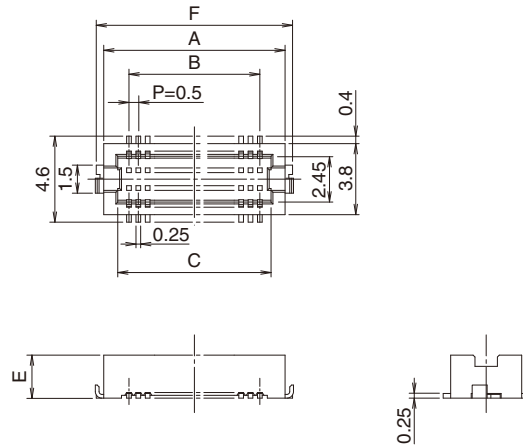

● Stacking Height : 3mm Product

Unit : mm

Part No.	HRS No.	No. of Contacts	A	B	C	E	F	Remarks	RoHS
DF12NB(3.0)-10DP-0.5V(51)	537-0299-0 51	10	4.7	2.0	3.2	2.3	5.6	With metal fitting	YES
DF12NB(3.0)-14DP-0.5V(51)	537-0387-0 51	14	5.7	3.0	4.2		6.6		
DF12NB(3.0)-20DP-0.5V(51)	537-0388-0 51	20	7.2	4.5	5.7		8.1		
DF12NB(3.0)-30DP-0.5V(51)	537-0389-0 51	30	9.7	7.0	8.2		10.6		
DF12NB(3.0)-32DP-0.5V(51)	537-0390-0 51	32	10.2	7.5	8.7		11.1		
DF12NB(3.0)-36DP-0.5V(51)	537-0391-0 51	36	11.2	8.5	9.7		12.1		
DF12NB(3.0)-40DP-0.5V(51)	537-0392-0 51	40	12.2	9.5	10.7		13.1		
DF12NB(3.0)-50DP-0.5V(51)	537-0393-0 51	50	14.7	12.0	13.2		15.6		
DF12NB(3.0)-60DP-0.5V(51)	537-0394-0 51	60	17.2	14.5	15.7		18.1		
DF12NB(3.0)-80DP-0.5V(51)	537-0395-0 51	80	22.2	19.5	20.7		23.1		

Note : Please order the embossed tape packaging product per reel. (1000 pcs./reel)

■ Header With metal fitting

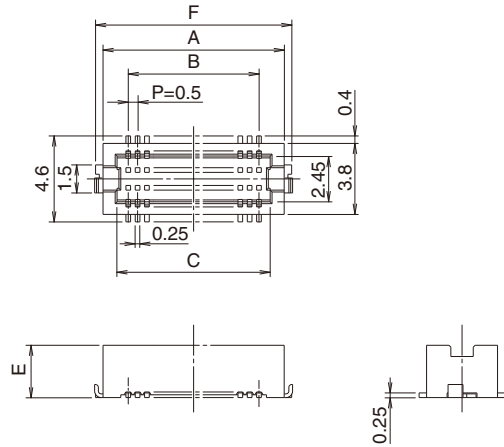

● Stacking Height : 3.5 to 5mm Product

Unit : mm

Part No.	HRS No.	No. of Contacts	A	B	C	E	F	Remarks	RoHS
DF12NB(3.5)-20DP-0.5V(51)	537-0493-0 51	20	7.2	4.5	5.7	2.8	8.1	With metal fitting	YES
DF12NB(3.5)-30DP-0.5V(51)	537-0494-0 51	30	9.7	7.0	8.2		10.6		
DF12NB(3.5)-36DP-0.5V(51)	537-0495-0 51	36	11.2	8.5	9.7		12.1		
DF12NB(3.5)-40DP-0.5V(51)	537-0496-0 51	40	12.2	9.5	10.7		13.1		
DF12NB(3.5)-50DP-0.5V(51)	537-0497-0 51	50	14.7	12.0	13.2		15.6		
DF12NB(3.5)-60DP-0.5V(51)	537-0498-0 51	60	17.2	14.5	15.7		18.1		
DF12NB(4.0)-20DP-0.5V(51)	537-0592-0 51	20	7.2	4.5	5.7	3.3	8.1		
DF12NB(4.0)-30DP-0.5V(51)	537-0593-0 51	30	9.7	7.0	8.2		10.6		
DF12NB(4.0)-32DP-0.5V(51)	537-0594-0 51	32	10.2	7.5	8.7		11.1		
DF12NB(4.0)-36DP-0.5V(51)	537-0595-0 51	36	11.2	8.5	9.7		12.1		
DF12NB(4.0)-40DP-0.5V(51)	537-0596-0 51	40	12.2	9.5	10.7		13.1		
DF12NB(4.0)-50DP-0.5V(51)	537-0597-0 51	50	14.7	12.0	13.2		15.6		
DF12NB(4.0)-60DP-0.5V(51)	537-0598-0 51	60	17.2	14.5	15.7	18.1			
DF12NB(5.0)-20DP-0.5V(51)	537-0877-0 51	20	7.2	4.5	5.7	4.3	8.1		
DF12NB(5.0)-30DP-0.5V(51)	537-0878-0 51	30	9.7	7.0	8.2		10.6		
DF12NB(5.0)-36DP-0.5V(51)	537-0879-0 51	36	11.2	8.5	9.7		12.1		
DF12NB(5.0)-40DP-0.5V(51)	537-0880-0 51	40	12.2	9.5	10.7		13.1		
DF12NB(5.0)-50DP-0.5V(51)	537-0881-0 51	50	14.7	12.0	13.2		15.6		
DF12NB(5.0)-60DP-0.5V(51)	537-0882-0 51	60	17.2	14.5	15.7		18.1		

Note : Please order the embossed tape packaging product per reel. (1000 pcs./reel)

◆ Embossed Carrier Tape Dimensions

● Receptacle

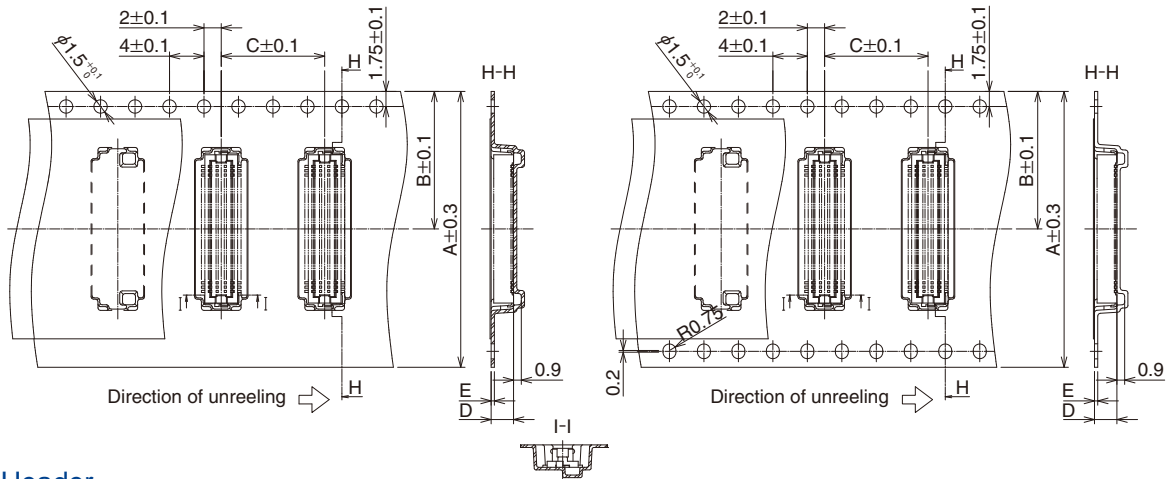

● Header

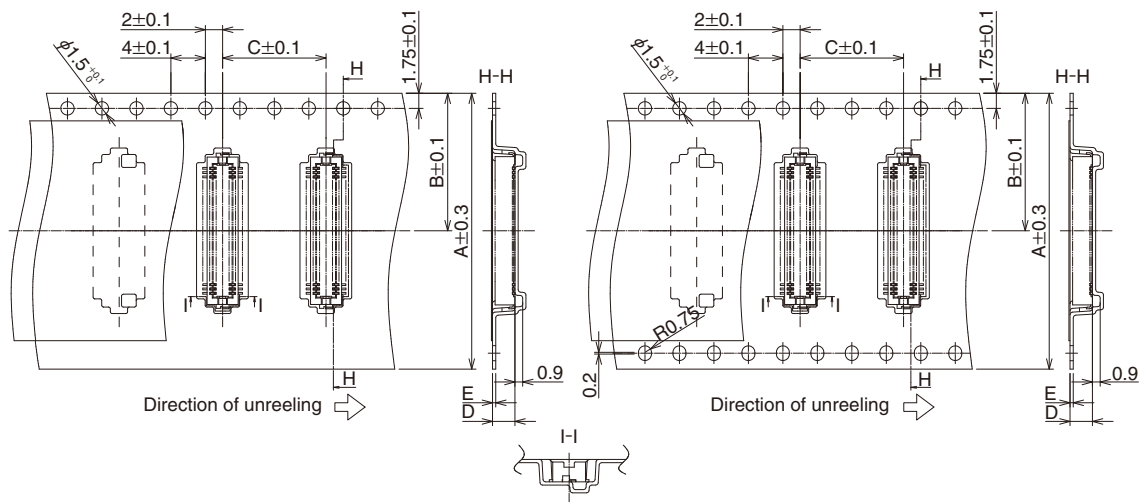

Connector	A	B	C	D	E	F	G	Connector	A	B	C	D	E	F	G
DF12#(3.0)-10DS-0.5V	16	7.5			0.30	17.5	21.5	DF12#(3.5)-20DP-0.5V	16	7.5	12		0.38	17.5	21.5
DF12#(3.0)-14DS-0.5V								DF12#(3.5)-30DP-0.5V							
DF12#(3.0)-20DS-0.5V								DF12#(3.5)-36DP-0.5V							
DF12#(3.0)-30DS-0.5V	24	11.5			0.38	25.5	29.5	DF12#(3.5)-40DP-0.5V	24	11.5	8	3.1	0.30	25.5	29.5
DF12#(3.0)-32DS-0.5V								DF12#(3.5)-50DP-0.5V							
DF12#(3.0)-36DS-0.5V								DF12#(3.5)-60DP-0.5V							
DF12#(3.0)-40DS-0.5V	32	14.2			0.38	33.5	37.5	DF12#(3.5)-20DP-0.5V	16	7.5	12		0.38	17.5	21.5
DF12#(3.0)-50DS-0.5V								DF12#(4.0)-30DP-0.5V							
DF12#(3.0)-60DS-0.5V								DF12#(4.0)-32DP-0.5V							
DF12#(3.0)-80DS-0.5V	44	20.2	12	2.6	0.30	45.5	49.5	DF12#(4.0)-36DP-0.5V	24	11.5	8	3.6	0.30	25.5	29.5
DF12#(3.0)-10DP-0.5V	DF12#(4.0)-40DP-0.5V														
DF12#(3.0)-14DP-0.5V	DF12#(4.0)-50DP-0.5V														
DF12#(3.0)-20DP-0.5V	16	7.5	12		0.38	25.5	29.5	DF12#(4.0)-60DP-0.5V	32	14.2			0.38	33.5	37.5
DF12#(3.0)-30DP-0.5V								DF12#(5.0)-20DP-0.5V							
DF12#(3.0)-32DP-0.5V								DF12#(5.0)-30DP-0.5V							
DF12#(3.0)-36DP-0.5V	24	11.5			0.38	25.5	29.5	DF12#(5.0)-36DP-0.5V	24	11.5	12	4.6	0.38	25.5	29.5
DF12#(3.0)-40DP-0.5V								DF12#(5.0)-40DP-0.5V							
DF12#(3.0)-50DP-0.5V								DF12#(5.0)-50DP-0.5V							
DF12#(3.0)-60DP-0.5V	32	14.2			0.38	33.5	37.5	DF12#(5.0)-60DP-0.5V	32	14.2	12		0.38	33.5	37.5
DF12#(3.0)-80DP-0.5V															
DF12#-20DS-0.5V								16							
DF12#-30DS-0.5V	24	11.5													
DF12#-32DS-0.5V															
DF12#-36DS-0.5V			8	12	0.30	25.5	29.5								
DF12#-40DS-0.5V															
DF12#-50DS-0.5V															
DF12#-60DS-0.5V	32	14.2	12		0.38	33.5	37.5								

● Reel Dimensions

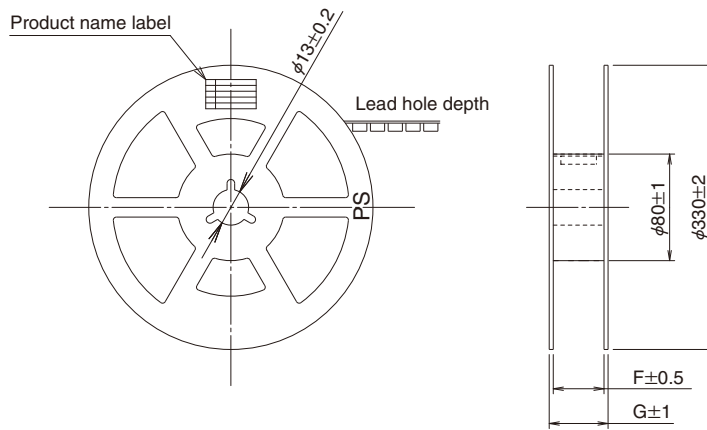

Refer to former page for F, G dimensions.

◆ Recommended PCB mounting pattern

■ DF12N with metal fitting

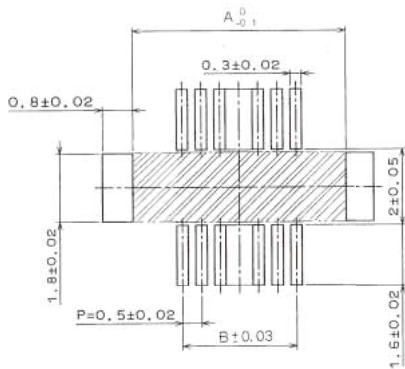

■ DF12N without metal fitting

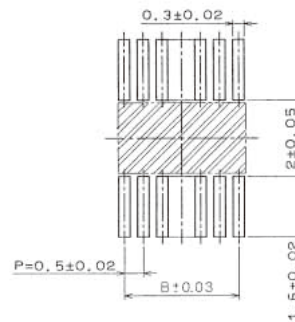

Note 1 : Refer to 3 to 8 for sides A and B.

Note 2 :  If the pattern is included in the shaded area, and not treated with resist, it could touch the connector contact.

◆ Precautions for Use

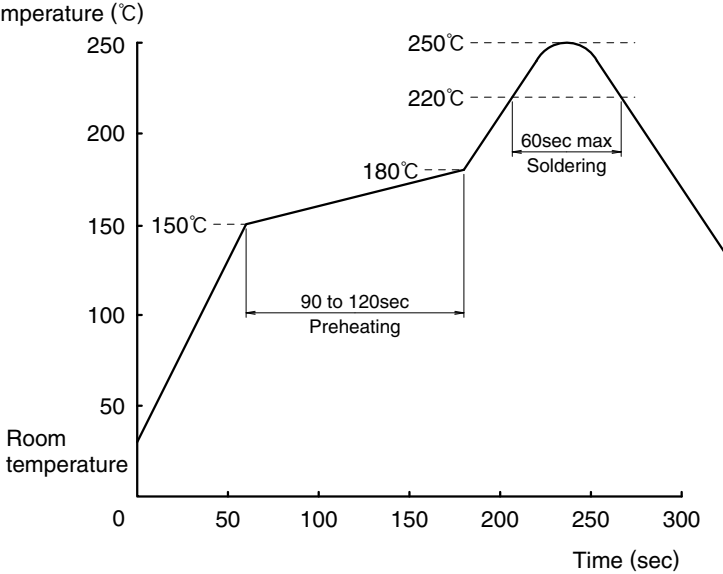
1.Recommended Temperature Profile (SMT)	 <p>Note1 : UP to 2 cycles of Reflow soldering are possible under the same conditions, provided that there is a return to normal temperature between the first and second cycle.</p> <p>Note2 : The temperature profile indicates the board surface temperature at the point of contacts with the connector terminals.</p>
2.Recommended Manual Soldering Condition (SMT)	Soldering iron temperature : 350°C, Soldering time : Within 3 seconds
3.Recommended Screen Thickness and open area ratio(Pattern area ratio)	0.12mm Open area ratio : 70%
4.Board Warp(SMT)	Maximum 0.02mm in the connector center area, based on both connector edges
5.Cleaning Condition	Refer to "Nylon Connector Use Hand book".
6.Cautions	<ul style="list-style-type: none"> ■ The receptacle is designed in a structure where contacts are exposed. Touching it with bare hands would cause contact failure or electrostatic element damage. ■ Where no board is mounted, the insertion or extraction will cause damage or contact deformation. ■ Avoid retaining the board with the connector only, and fix the board by any other means than the connector. ■ Excessive scoop insertion or extraction may result in damage. ■ In the manual soldering process, don't carry out the flux coating which will cause a flux blister on the connector. ■ The color phase of this product may be slightly different from that of the formed product according to the manufacturing lot. However, the difference doesn't affect the performance.



HIROSE ELECTRIC CO.,LTD.

2-6-3,Nakagawa Chuoh,Tsuzuki-Ku,Yokohama-Shi 224-8540,JAPAN
 TEL: +81-45-620-3526 Fax: +81-45-591-3726
<http://www.hirose.com>
<http://www.hirose-connectors.com>

X-ON Electronics

Largest Supplier of Electrical and Electronic Components

Click to view similar products for [Board to Board & Mezzanine Connectors](#) category:

Click to view products by [Hirose](#) manufacturer:

Other Similar products are found below :

[10135583-642402LF](#) [89885-310LF](#) [589158040000018](#) [6-1393048-0](#) [68683-613](#) [MDF7-12DP-2.54DSA](#) [MDF7-18P-2.54DSA\(01\)](#) [MDF7-20DP-2.54DSA](#) [MDF7-26D-2.54DSA\(55\)](#) [MDF7-3P-2.54DSA\(01\)](#) [MDF7B-20P-2.54DSA\(01\)](#) [MDF7B-3P-2.54DSA\(55\)](#) [MDF7C-11P-2.54DSA\(55\)](#) [MDF7C-18P-2.54DSA\(55\)](#) [MDF7C-5P-2.54DSA\(01\)](#) [MDF7P-5P-2.54DSA\(55\)](#) [75234-0516](#) [FCN-230C068-11](#) [FCN-268F012-G/BD](#) [FCN-268F036-G/BD](#) [FCN-268M012-G/0D](#) [FCN-268M024-G/1D](#) [FCN-360C008-C](#) [FCN-723J004/1](#) [MIS-048-01-F-D-DP-K](#) [832-10-034-10-001000](#) [93696-325LF](#) [11828-1FA](#) [AXK630345P](#) [18097-0013](#) [ICA-328STT](#) [2007042-2](#) [304400-2](#) [FCN-214Q030-G/0](#) [FCN-215Q040-G/0](#) [FCN-230C068-ESA](#) [FCN-234P048-G/0](#) [FCN-235D050-G/C](#) [FCN-360A3](#) [FCN-360C040-B](#) [210-93-314-41-105000](#) [2-22603-0](#) [379-064-521-202](#) [MDF7-12P-2.54DSA\(01\)](#) [MDF7-16P-2.54DSA\(55\)](#) [MDF7-8P-2.54DSA\(55\)](#) [AXG720047](#) [5031084030](#) [55323-1519](#) [DF33-2P-3.3DSA\(24\)](#)