

Aug.1.2020 Copyright 2020 HIROSE ELECTRIC CO., LTD. All Rights Reserved.
In case of consideration for using Automotive equipment / device which demand high reliability, kindly contact our sales window correspondents.

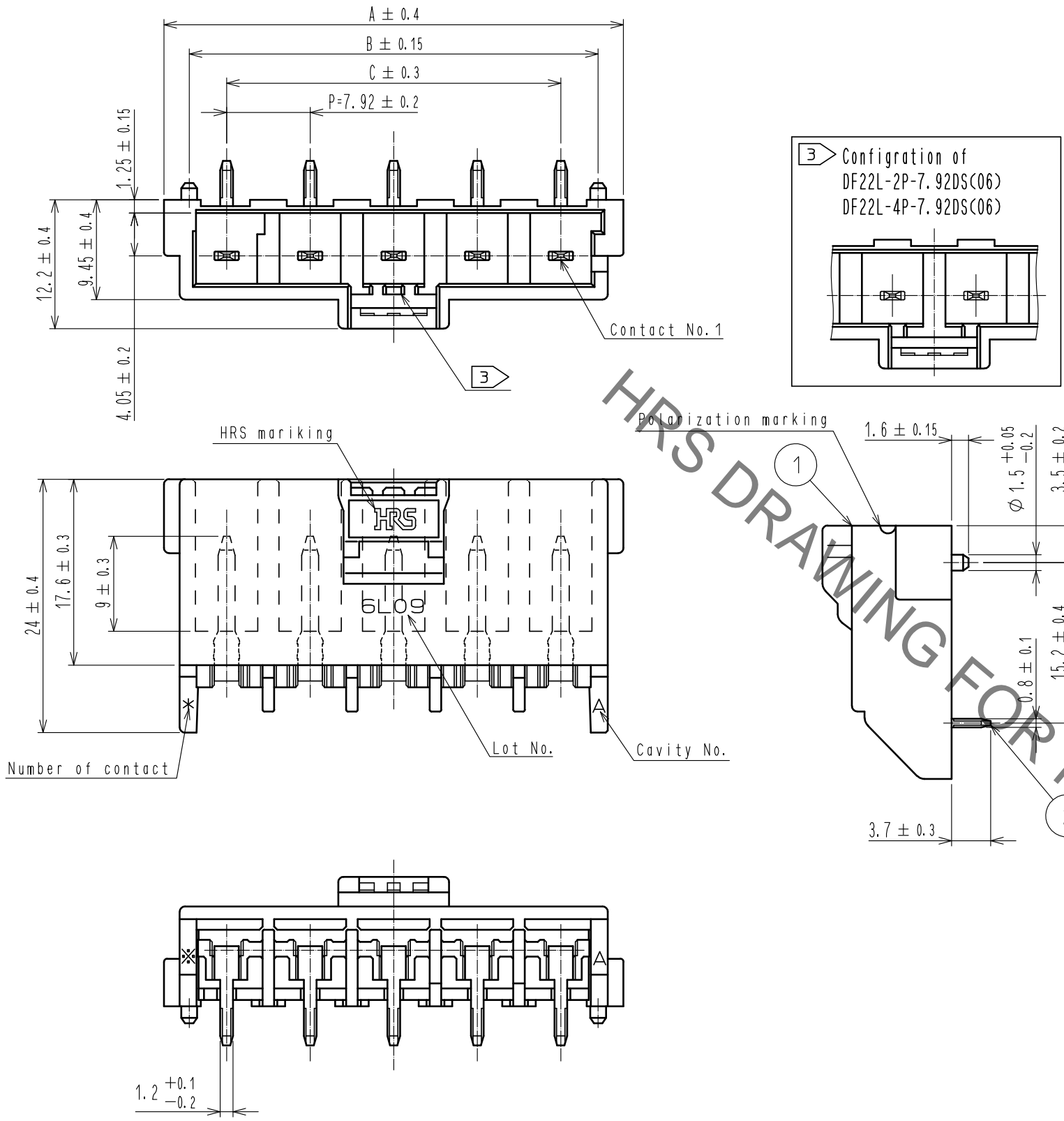
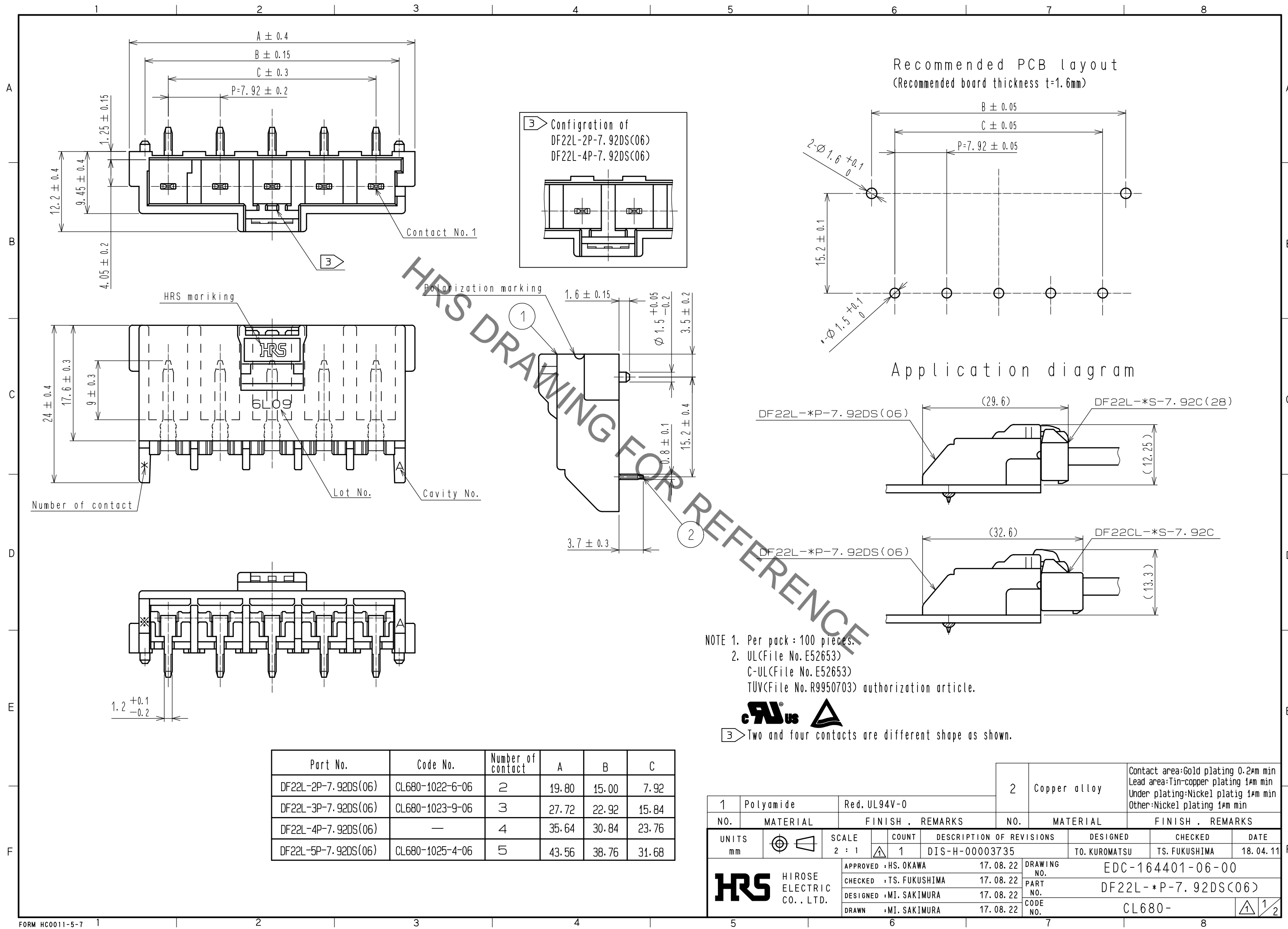

Part No.	Code No.	Number of contact	A	B	C
DF22L-2P-7.92DS(06)	CL680-1022-6-06	2	19.80	15.00	7.92
DF22L-3P-7.92DS(06)	CL680-1023-9-06	3	27.72	22.92	15.84
DF22L-4P-7.92DS(06)	—	4	35.64	30.84	23.76
DF22L-5P-7.92DS(06)	CL680-1025-4-06	5	43.56	38.76	31.68

1	Polyamide	Red. UL94V-0	2	Copper alloy	Contact area:Gold plating 0.2μm min Lead area:Tin-copper plating 1μm min Under plating:Nickel plating 1μm min Other:Nickel plating 1μm min
NO.	MATERIAL	FINISH . REMARKS	NO.	MATERIAL	FINISH . REMARKS
UNITS mm		SCALE 2 : 1	COUNT 1	DESCRIPTION OF REVISIONS DIS-H-00003735	DESIGNED TO. KUROMATSU
APPROVED : HS. OKAWA 17.08.22			DRAWING NO. EDC-164401-06-00		
CHECKED : TS. FUKUSHIMA 17.08.22			PART NO. DF22L-*P-7.92DS(06)		
DESIGNED : MI. SAKIMURA 17.08.22			CODE NO. CL680-		
DRAWN : MI. SAKIMURA 17.08.22			DATE 18.04.11		

Aug.1.2020 Copyright 2020 HIROSE ELECTRIC CO., LTD. All Rights Reserved.
In case of consideration for using Automotive equipment / device which demand high reliability, kindly contact our sales window correspondents.



Precautions

Notification for Insertion Extraction

1) Please insert(extract) the crimping socket straight to the mating connector.
Insertion(extraction) at tilted angles applies load concentration to the connector end and may cause deformation (at connection area, socket and header case, etc). There is firing risk using this kind of deformed connector.

Insertion(Extraction)

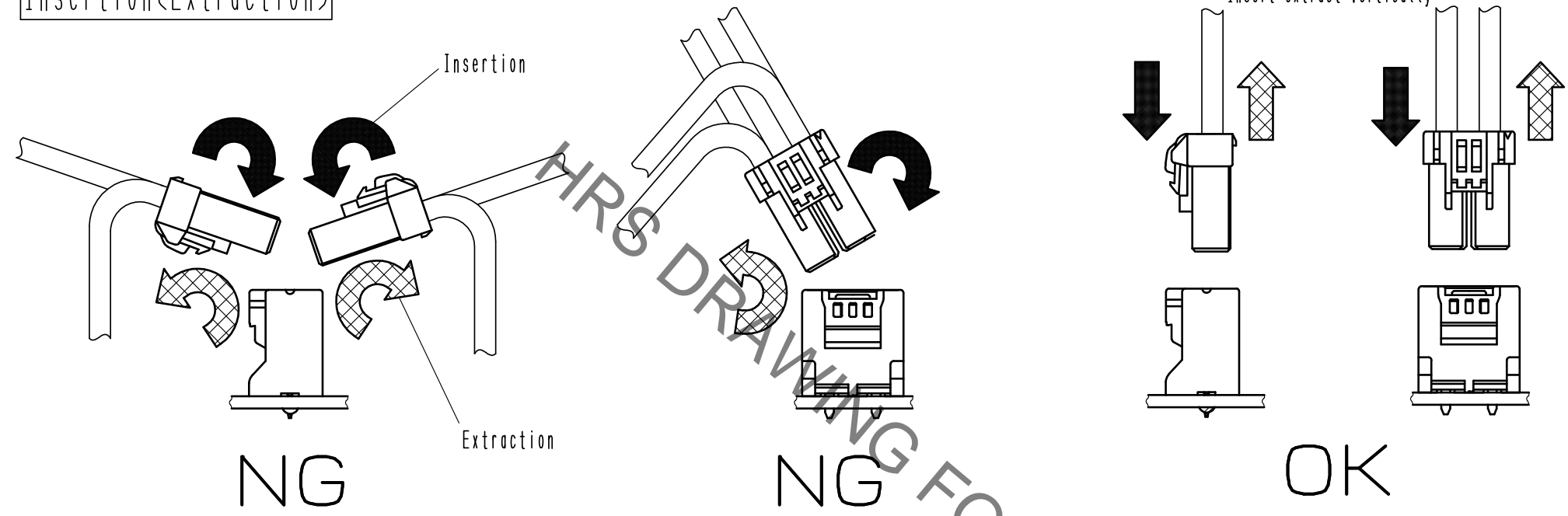

2) When it is hard to extract, please lightly insert the connector beforehand and then pull it with releasing the lock.
Forced extraction has a risk of connector breakage.

Notification of wiring

1) When using a thick cable, short cable length and bending close to the connector end, these load concentration may cause deformation.
Please note that there is firing risk using deformed connector.
When installing, please refrain from stress concentration such as cable bending close to the connector end or cable twisting.

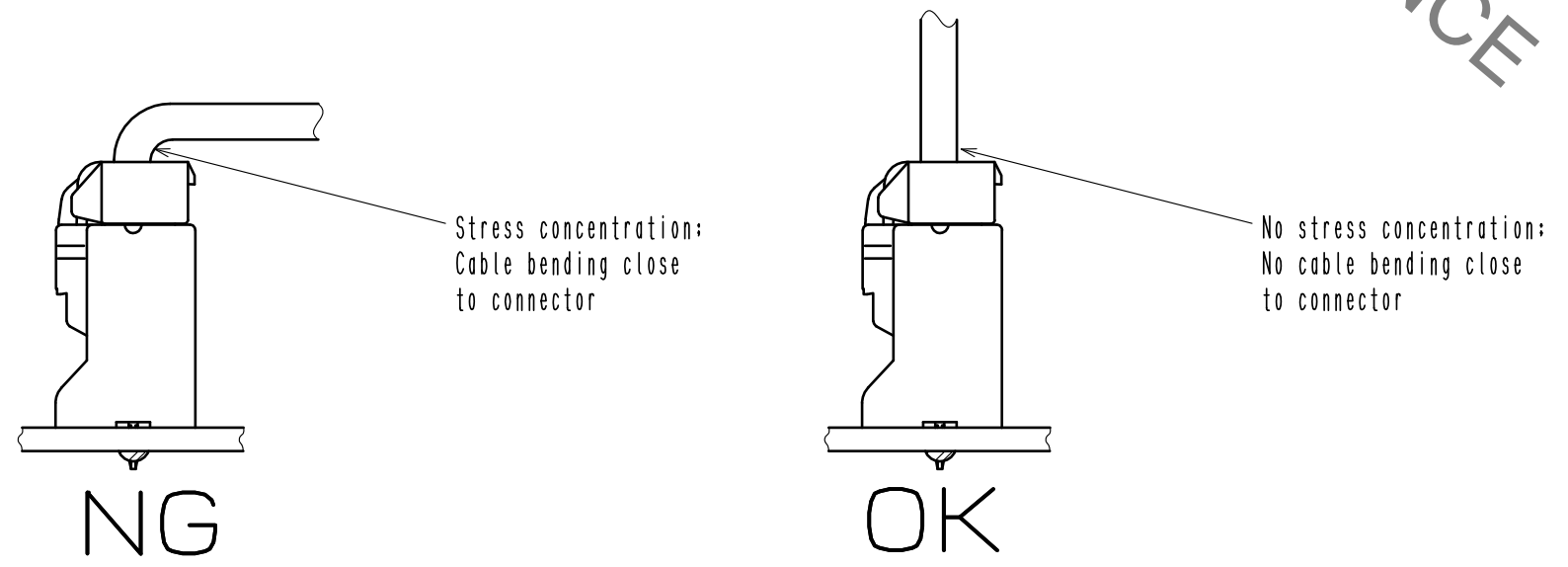

2) When applying load to connector end, please use the retainer for reducing the stress affection on the connector.
Retainer shall be installed after inserted crimping contact completely. It might be impossible to insert it when terminal installation is incompletd.



HRS	DRAWING NO.	EDC-164401-06-00
	PART NO.	DF22L-*P-7.92DS(06)
	CODE NO.	CL680-
		2/2

X-ON Electronics

Largest Supplier of Electrical and Electronic Components

Click to view similar products for [FFC & FPC Connectors](#) category:

Click to view products by [Hirose](#) manufacturer:

Other Similar products are found below :

[HFW11R-1STE1H1LF](#) [FH29B-100S-0.2SHW\(99\)](#) [FA5S008HP1](#) [FH29B-120S-0.2SHW\(99\)](#) [FH29B-80S-0.2SHW\(99\)](#) [FHS-16](#) [FPH-2022G](#)
[52610-1075](#) [52610-1275](#) [52610-1934](#) [XF3M\(1\)-1415-1B-R100](#) [501864-3091-TR225](#) [0525594033](#) [086210010340800](#) [086222026001800](#)
[52271-2869-CUT-TAPE](#) [62684-36210E9ALF](#) [52610-1675](#) [52746-1671-TR250](#) [AYF330735](#) [10051922-2810EHLF](#) [6-520415-9](#) [BD021-09A-](#)
[A1-0350-0200-0550-LD](#) [SFV6R-1STE9HLF](#) [XF3M-2915-1B-R100](#) [1658549-1](#) [62674-221121ALF](#) [151660622](#) [842-816-2630-035](#)
[AYF530665TA](#) [AYF351525](#) [046296011930846+](#) [AYF352325A](#) [046254020000800+](#) [FH19C-13S-0.5SH\(99\)](#) [FH39J-51S-0.3SHW\(99\)](#)
[AYF530365TA](#) [FH29B-44S-0.2SHW\(99\)](#) [SFW5R-2STAE9LF](#) [62684-502100AHLF](#) [FH39-61S-0.3SHW\(99\)](#) [AYF414035A](#) [10064555-](#)
[172520HLF](#) [AYF212335A](#) [504754-2500](#) [SFW7S-2STME1LF](#) [FH39-45S-0.3SHW\(99\)](#) [MA49-19S-2.54DSA](#) [FH19SC-12S-0.5SH\(99\)](#)
[SFW6S-2STE9LF](#)