

Aug.1.2021 Copyright 2021 HIROSE ELECTRIC CO., LTD. All Rights Reserved.
In case of consideration for using Automotive equipment / device which demand high reliability, kindly contact our sales window correspondents.

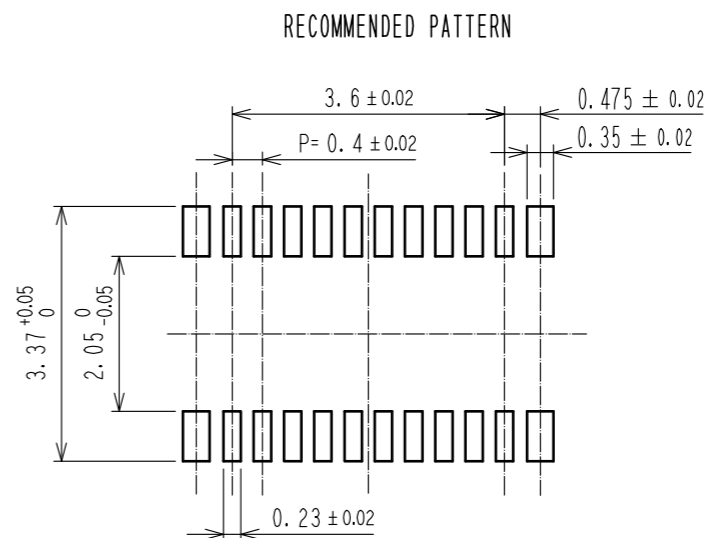

RECOMMENDED METAL MASK THICKNESS : 120 μm
RECOMMENDED METAL MASK OPENING RATIO : 80% FOR LEAD PAD

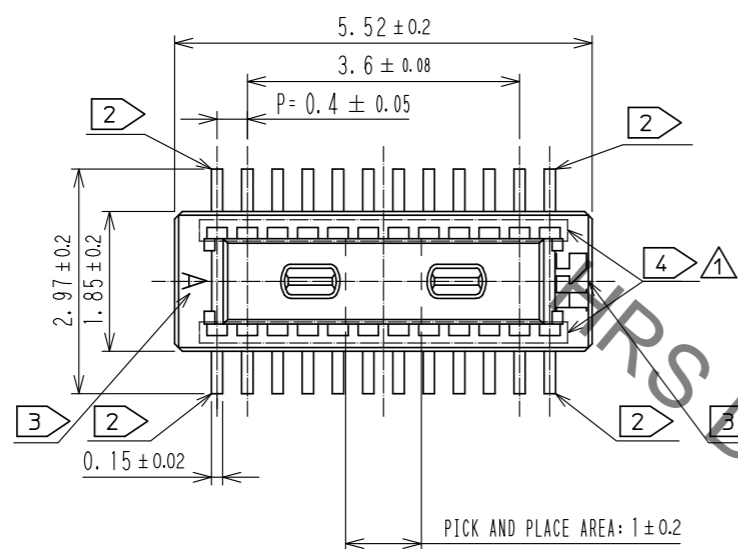
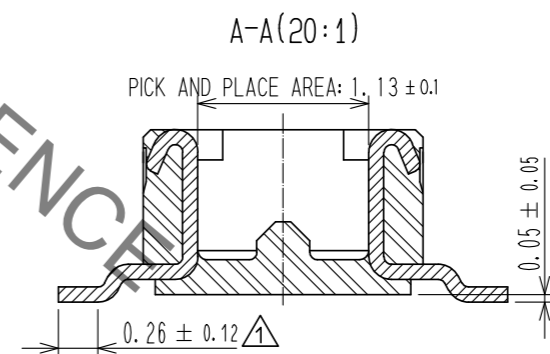
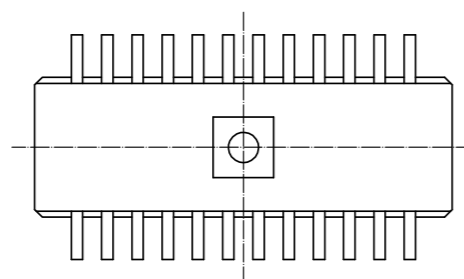
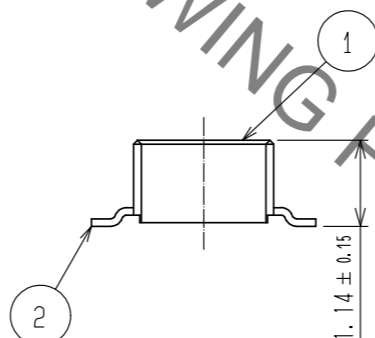
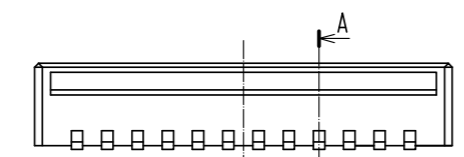

- NOTES
- 1. ALL LEADS CO-PLANARITY SHALL BE 0.1mm MAX.
 - 2 EACH ONE CONTACT AT 4 CORNERS SHALL BE USED AS METAL HOLD DOWN.
 - 3 HRS MARK AND CAV NO. IS INDICATED IN APPROXIMAL POSITION SHOWN.
THE INDICATION COULD BE ON THE UPPER SURFACE OF DESIGN ON THE CONNECTOR.
 - 4 THERE IS A POSSIBILITY THAT THE RESIN WILL BE EXPOSED AT THIS AREA,
BUT THIS WILL NOT AFFECT THE CONTACT RELIABILITY.

NO.	MATERIAL	FINISH . REMARKS	NO.	MATERIAL	FINISH . REMARKS
2	PHOSPHOR BRONZE	CONTACT AREA:GOLD 0.05 μm MIN	6	PS	CLEAR, REINFORCEMENT COLLAR
		SMT LEAD:GOLD 0.05 μm MIN	5	PS	BLACK, PLASTIC REEL
		UNDERPLATING:NICKEL 1 μm MIN	4	POLYESTER	CLEAR, COVER TAPE
1	LCP	BLACK, UL94V-0	3	PS	CLEAR, EMBOSSED CARRIER TAPE

UNITS	SCALE	COUNT	DESCRIPTION OF REVISIONS	DESIGNED	CHECKED	DATE
mm	10:1	5	DIS-H-00006044	RH. KAGAMI	TS. MIYAZAKI	20200617

APPROVED	CHECKED	DESIGNED	DRAWN	DRAWING NO.	PART NO.	CODE NO.
MO. ISHIDA 20160616	TS. MIYAZAKI 20160616	SH. HOSODA 20160614	SN. NUMAZAKI 20160614	EDC-311342-58-00	DF40C-20DP-0.4V(58)	CL684-4010-9-58

Aug.1.2021 Copyright 2021 HIROSE ELECTRIC CO., LTD. All Rights Reserved.
 In case of consideration for using Automotive equipment / device which demand high reliability, kindly contact our sales window correspondents.

EMBOSSED CARRIER TAPE PACKAGING (5:1)

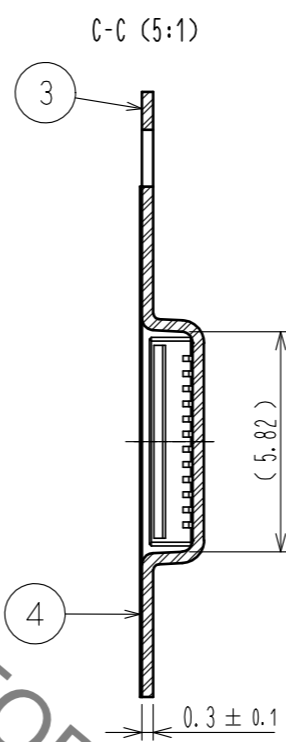
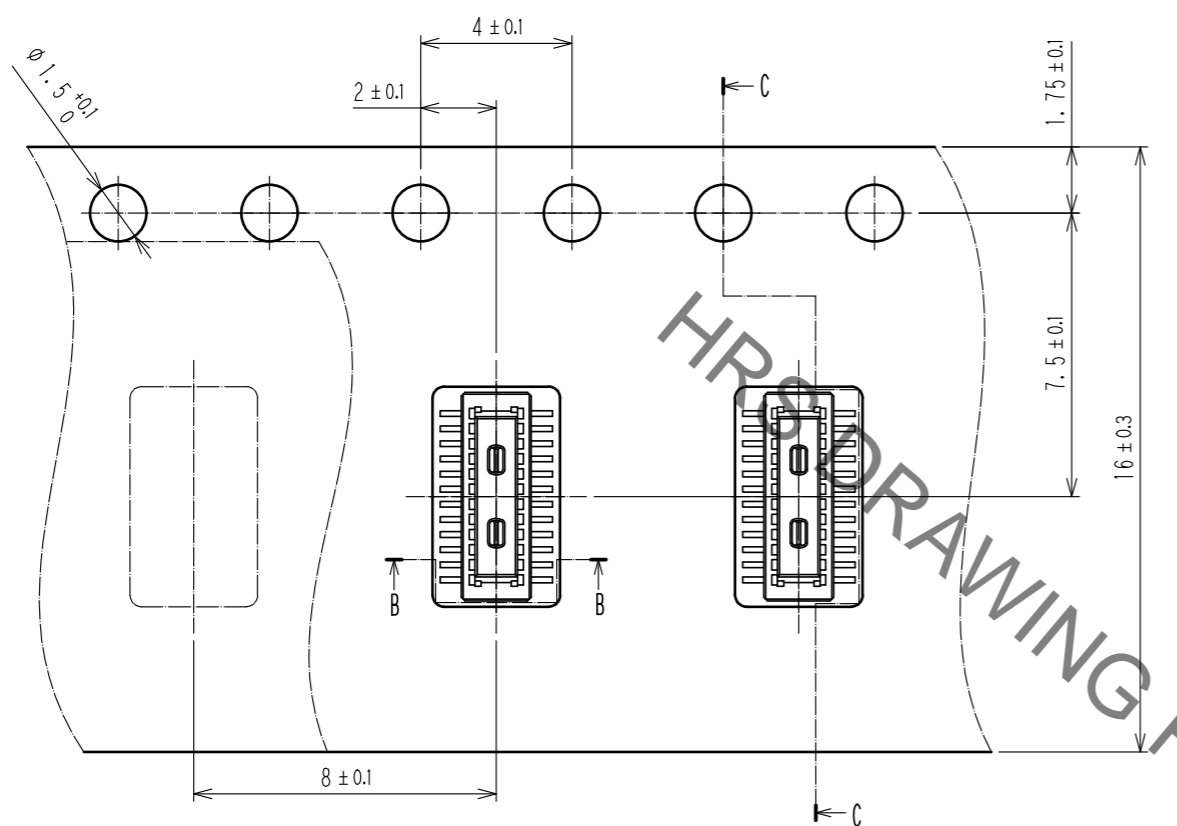

STYLE AND DIMENSION OF REEL (FREE)

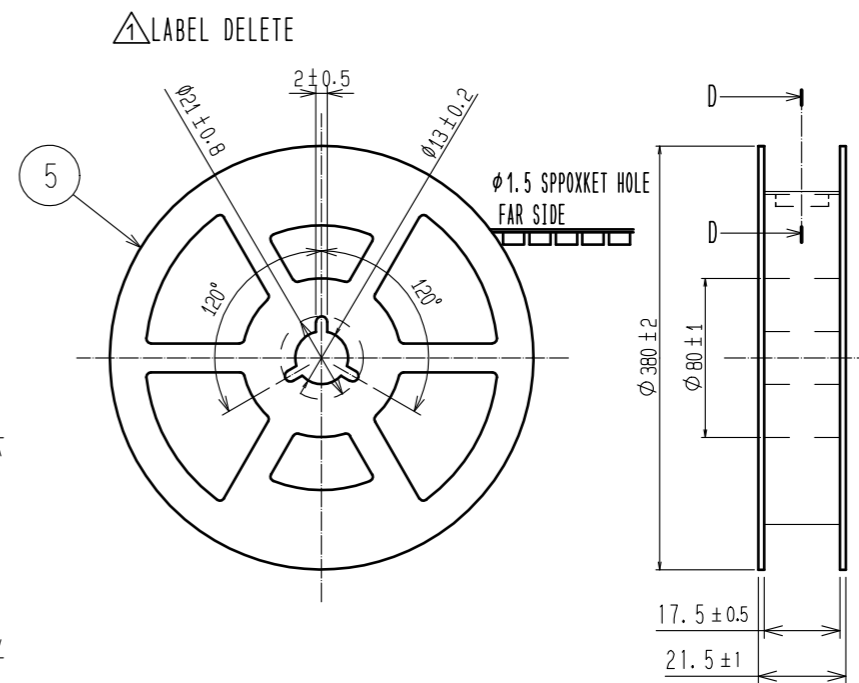

DETAIL OF LABEL DELETE

DIRECTION OF UNREELING \rightarrow

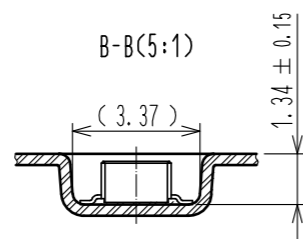

D-D (FREE)

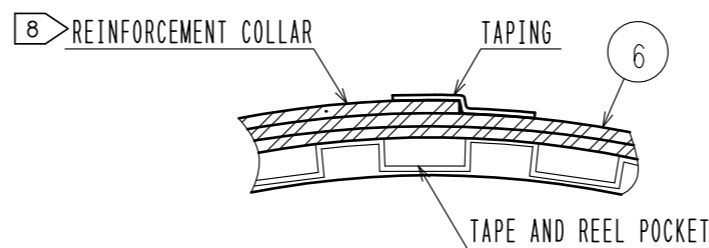

- NOTES
5. PER REEL 1000 CONNECTORS.
 6. THE DIMENSIONS IN PARENTHESES ARE FOR REFERENCE.
 7. REFER TO JIS C 0806, IEC 60286-3 (PACKING OF COMPONENTS FOR AUTOMATIC HANDLING)
 8. AFTER PACKAGING, ROLL 2 METERS OF THE REINFORCEMENT COLLAR TO OUTER CIRCUMFERENCE OF TAPE AND REEL POCKET, AND TAPE DOWN AT THE END THE COLLAR.

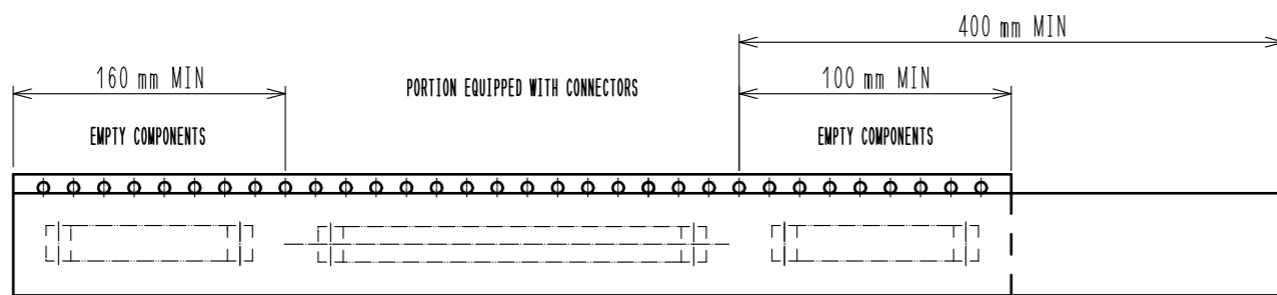

TRAILER

TAPING

LEADER

HRS	DRAWING NO.	EDC-311342-58-00
	PART NO.	DF40C-20DP-0.4V(58)
	CODE NO.	CL684-4010-9-58
		\triangle 2/2

X-ON Electronics

Largest Supplier of Electrical and Electronic Components

Click to view similar products for [Board to Board & Mezzanine Connectors](#) category:

Click to view products by [Hirose](#) manufacturer:

Other Similar products are found below :

[589158040000018](#) [MDF7C-18P-2.54DSA\(55\)](#) [FCN-230C068-11](#) [FCN-268F012-G/BD](#) [FCN-268F036-G/BD](#) [FCN-268M012-G/0D](#) [FCN-268M024-G/1D](#) [FCN-723J004/1](#) [MIS-048-01-F-D-DP-K](#) [832-10-034-10-001000](#) [FX4C-80S-1.27DSA](#) [FCN-214Q030-G/0](#) [FCN-234P048-G/0](#) [FCN-235D050-G/C](#) [210-93-314-41-105000](#) [2-22603-0](#) [MDF7-40DP-2.54DSA\(55\)](#) [AXG720047](#) [MIT-114-03-F-D-K](#) [55323-1519](#) [DF33-2P-3.3DSA\(24\)](#) [YFT-20-05-H-03-SB-K](#) [503308-3040](#) [026-6203-PDB](#) [027-6203-PDB](#) [069159702701000](#) [10123981-102LF](#) [101A10019X](#) [55650-0588-C](#) [68682-310LF](#) [68684-306](#) [75140-7012](#) [87471-650](#) [YTW-30-07-H-Q-410-140](#) [FCN-268F024-G0D](#) [10124054-515LF](#) [68685-603](#) [8-1616154-3](#) [MIS-019-01-F-D](#) [FCN-268M024-G/3D](#) [FCN-268M036-G/BD](#) [20021832-06016C1LF](#) [KX15-20KLDL-E1000E](#) [AXE810124](#) [FCN-214J100-G/0](#) [FCN-230C068-E/S](#) [AXE812124](#) [AXE816124](#) [AXE720127](#) [354184](#)