

Sep.1.2021 Copyright 2021 HIROSE ELECTRIC CO., LTD. All Rights Reserved.  
In case of consideration for using Automotive equipment / device which demand high reliability, kindly contact our sales window correspondents.

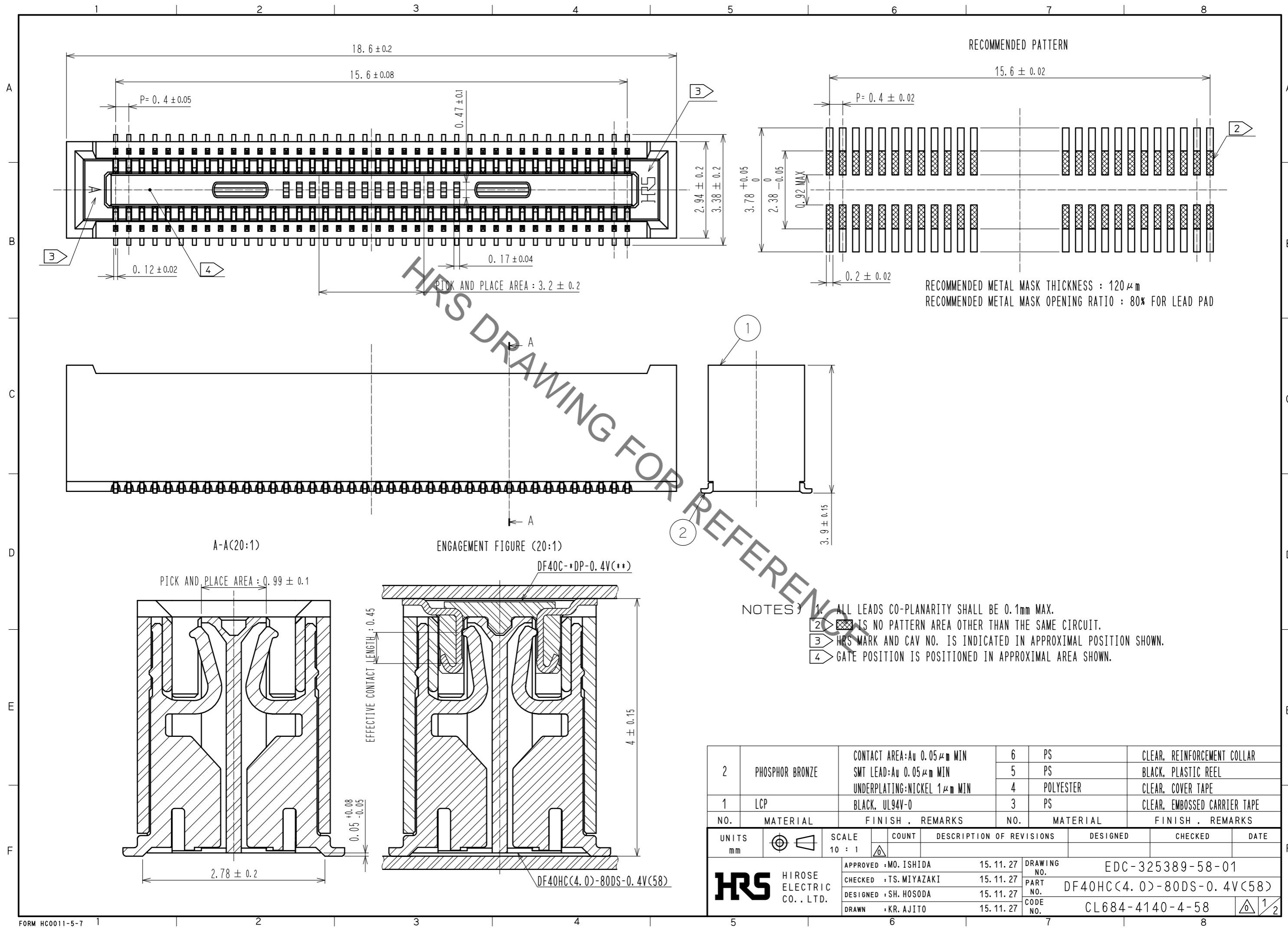

NO.	MATERIAL	FINISH . REMARKS	NO.	MATERIAL	FINISH . REMARKS
2	PHOSPHOR BRONZE	CONTACT AREA: Au 0.05 μm MIN SMT LEAD: Au 0.05 μm MIN UNDERPLATING: NICKEL 1 μm MIN	6	PS	CLEAR, REINFORCEMENT COLLAR
			5	PS	BLACK, PLASTIC REEL
			4	POLYESTER	CLEAR, COVER TAPE
1	LCP	BLACK, UL94V-0	3	PS	CLEAR, EMBOSSED CARRIER TAPE

  

UNITS	SCALE	COUNT	DESCRIPTION OF REVISIONS	DESIGNED	CHECKED	DATE
mm	10 : 1	△				
APPROVED : MO. ISHIDA			15.11.27	DRAWING NO. EDC-325389-58-01		
CHECKED : TS. MIYAZAKI			15.11.27	PART NO. DF40HC(4.0)-80DS-0.4V(58)		
DESIGNED : SH. HOSODA			15.11.27	CODE NO. CL684-4140-4-58		
DRAWN : KR. AJITO			15.11.27	1/2		

Sep.1.2021 Copyright 2021 HIROSE ELECTRIC CO., LTD. All Rights Reserved.  
In case of consideration for using Automotive equipment / device which demand high reliability, kindly contact our sales window correspondents.

EMBOSSED CARRIER TAPE PACKING(FREE)

STYLE AND DIMENSION OF REEL(FREE)

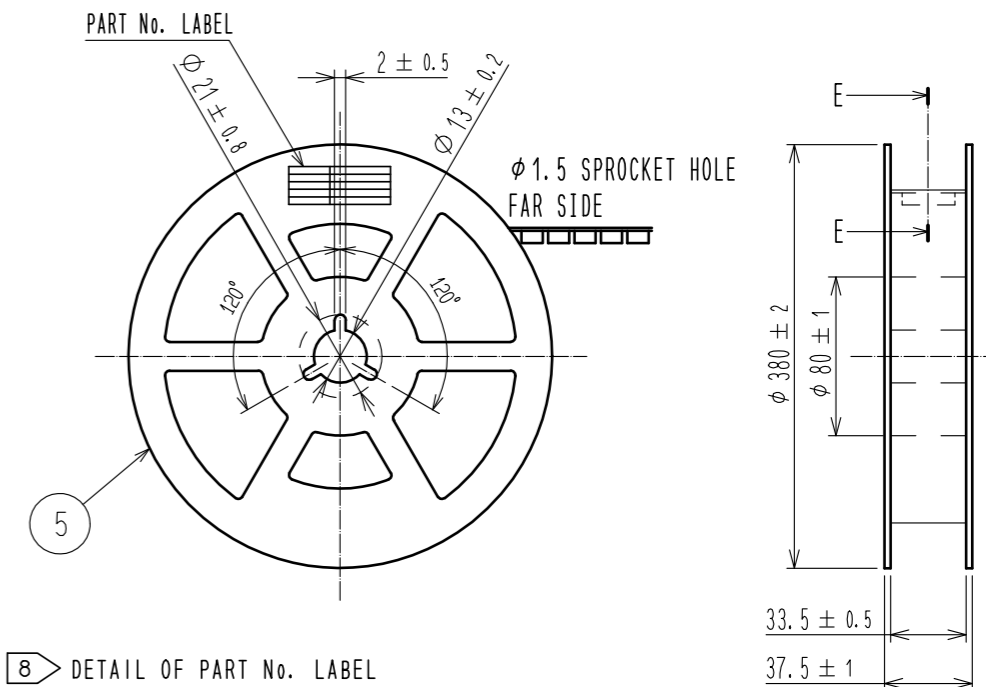
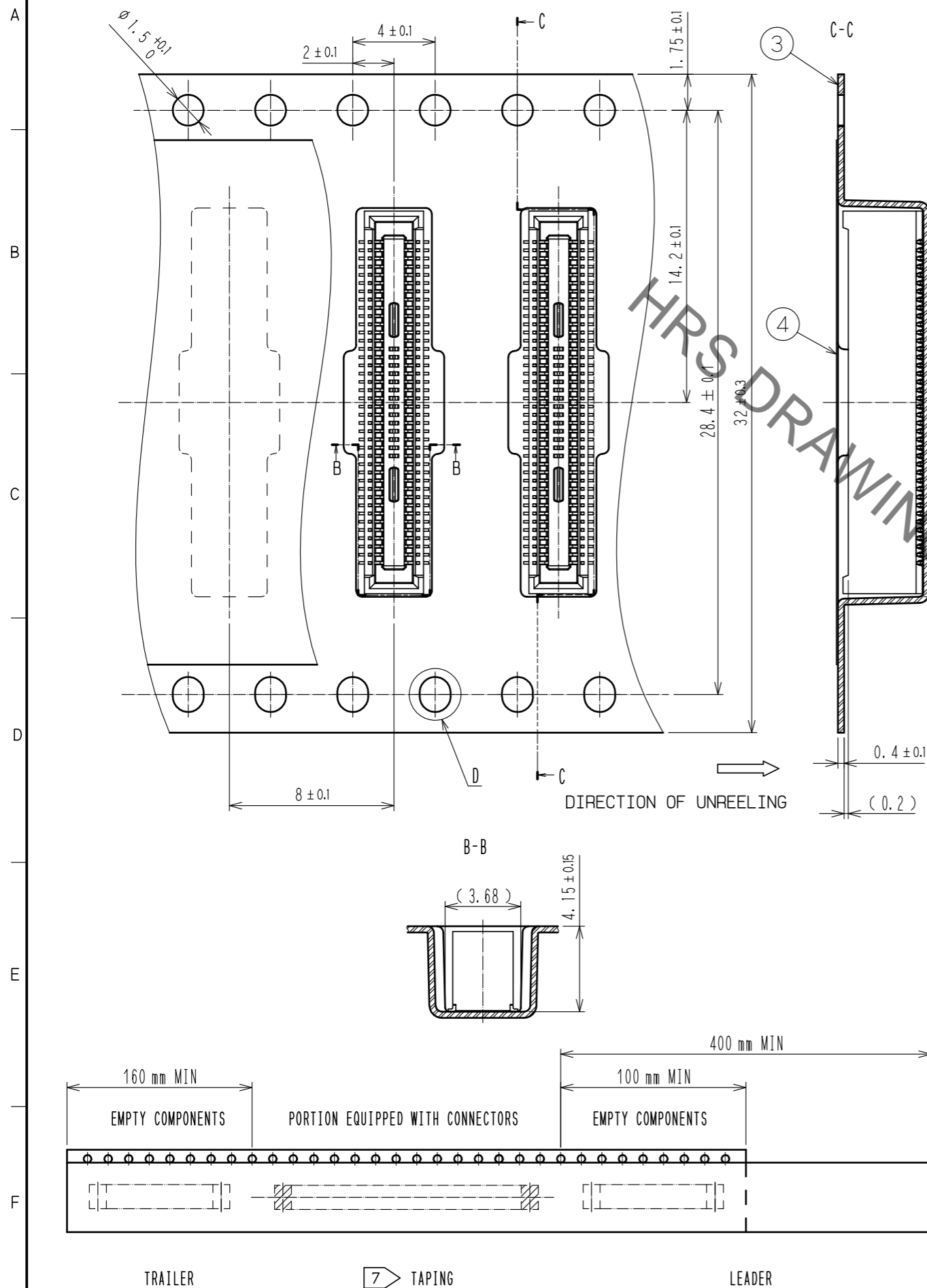

8) DETAIL OF PART No. LABEL

製造年月日	** ** *
製品コード	CL684-4140-4-58
製品名	DF40HC(4.0)-80DS-0.4V(58)
数量	1000
納入者	ヒロセ電機(株)

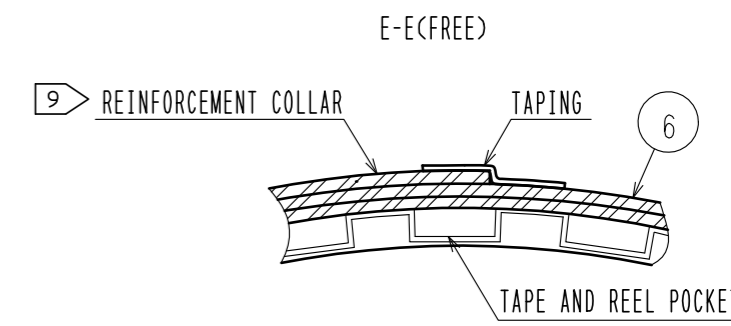

- NOTES
5. PER REEL 1000 CONNECTORS.
  6. THE DIMENSIONS IN PARENTHESES ARE FOR REFERENCE.
  7. REFER TO JIS C 0806, IEC 60286-3 (PACKING OF COMPONENTS FOR AUTOMATIC HANDLING)
  8. DETAIL OF PART No. LABEL IS WRITTEN IN JAPANESE. PART No. LABEL DESCRIBES THE FOLLOWING INFORMATION FROM TOP.  
PRODUCTION DATE:  
PRODUCT CODE: CL684-4140-4-58  
PART NUMBER: DF40HC(4.0)-80DS-0.4V(58)  
NUMBER OF PIECES: 1000 PIECES  
SUPPLIER NAME: HIROSE ELECTRIC CO., LTD.
  9. AFTER PACKAGING, ROLL 2 METERS OF THE REINFORCEMENT COLLAR TO OUTER CIRCUMFERENCE OF TAPE AND REEL POCKET, AND TAPE DOWN AT THE END THE COLLAR.

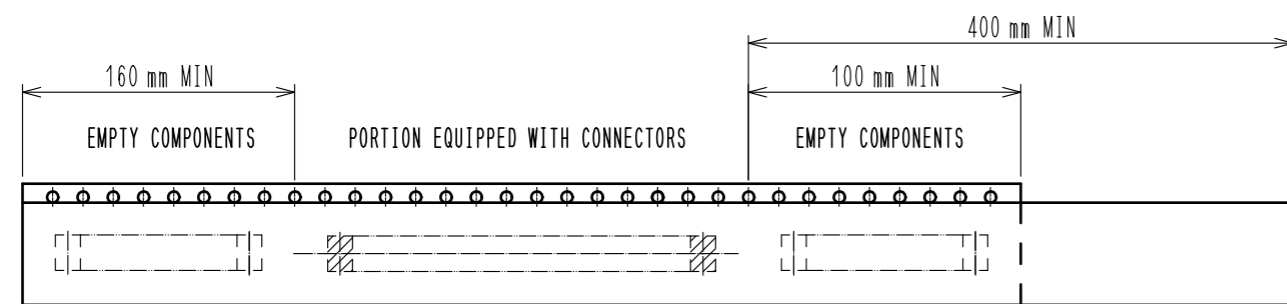

<b>HRS</b>	DRAWING NO.	EDC-325389-58-01
	PART NO.	DF40HC(4.0)-80DS-0.4V(58)
	CODE NO.	CL684-4140-4-58
		2/2

## X-ON Electronics

Largest Supplier of Electrical and Electronic Components

*Click to view similar products for [Board to Board & Mezzanine Connectors](#) category:*

*Click to view products by [Hirose](#) manufacturer:*

Other Similar products are found below :

[589158040000018](#) [MDF7C-18P-2.54DSA\(55\)](#) [FCN-230C068-11](#) [FCN-268F012-G/BD](#) [FCN-268F036-G/BD](#) [FCN-268M012-G/0D](#) [FCN-268M024-G/1D](#) [FCN-723J004/1](#) [MIS-048-01-F-D-DP-K](#) [832-10-034-10-001000](#) [FX4C-80S-1.27DSA](#) [FCN-214Q030-G/0](#) [FCN-234P048-G/0](#) [FCN-235D050-G/C](#) [210-93-314-41-105000](#) [2-22603-0](#) [MDF7-40DP-2.54DSA\(55\)](#) [AXG720047](#) [MIT-114-03-F-D-K](#) [55323-1519](#) [DF33-2P-3.3DSA\(24\)](#) [YFT-20-05-H-03-SB-K](#) [503308-3040](#) [026-6203-PDB](#) [027-6203-PDB](#) [069159702701000](#) [10123981-102LF](#) [101A10019X](#) [55650-0588-C](#) [68682-310LF](#) [68684-306](#) [75140-7012](#) [87471-650](#) [YTW-30-07-H-Q-410-140](#) [FCN-268F024-G0D](#) [10124054-515LF](#) [68685-603](#) [8-1616154-3](#) [MIS-019-01-F-D](#) [FCN-268M024-G/3D](#) [FCN-268M036-G/BD](#) [20021832-06016C1LF](#) [KX15-20KLDL-E1000E](#) [AXE810124](#) [FCN-214J100-G/0](#) [FCN-230C068-E/S](#) [AXE812124](#) [AXE816124](#) [AXE720127](#) [354184](#)