

1. Scope

This document specifies the steps to insert or remove the DF62W series.

It contains general guidelines and precautions for the safe use of the product. The use of the product in a way not as specified in the document could result in unexpected troubles such as damage to connectors. Please make sure to thoroughly read and understand the document prior to the use of the product.

2. Connectors

○Connectors

DF62W # - * EP - 2.2 C

① ② ③ ④ ⑤ ⑥

①	Series: DF62W
②	Style Symbol <ul style="list-style-type: none"> • Socket / In-line plug Blank: Standard type A to E: Different wire seal type • Header Blank or Z: Standard type
③	No. of poles: 2~9
④	Connector types <ul style="list-style-type: none"> S : Socket EP: In-line plug P : Header
⑤	Terminal pitch: 2.2mm
⑥	Shape of connection / terminal <ul style="list-style-type: none"> C : Crimping case DSA : Straight pin header

○Terminals

DF62W - EP 2226 PCF A

① ② ③ ④

①	Application EP: In-line
②	Compatible cables 2022: AWG20 to 22 2226: AWG22 to 26 2830: AWG28 to 30
③	Shape / packing SCF : Socket terminal, reeled SC : Socket terminal, separate PCF : Plug terminal, reeled PC : Plug terminal, separate
④	Plating A : Gold plating Blank: Tin plating

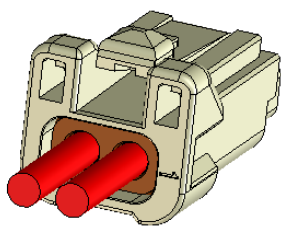

(E.g.) DF62W-2S-2.2C
+DF62W-2226SCF
(Cables attached)

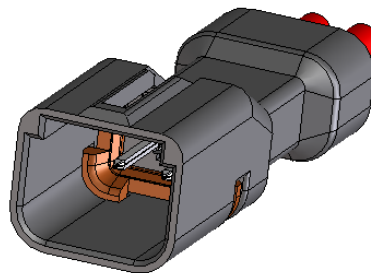

(E.g.) DF62W-2EP-2.2C
+DF62W-EP2226PCF
(Cables attached)

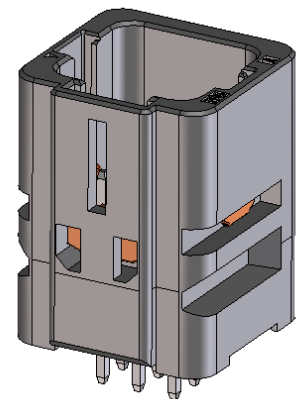

(E.g.) DF62W-9P-2.2DSA

Fig.1 DF62W connector

COUNT	DESCRIPTION OF REVISIONS	DESIGNED	CHECKED	DATE	
③ 5	DIS-H-00006326	KI.SUGAWARA	ST.WADA	20201006	
TITLE					
DF62W Series Mating / Unmating Operation Instruction Manual					
APPROVED	KI.AKIYAMA				20140215
CHECKED	OM.MIYAMOTO				20140214
DESIGNED	KT.ISHII	20140213			
WRITTEN	KT.ISHII	20140213			
TECHNICAL SPECIFICATION		ETAD-H0761	③	1 / 8	

△ ○ Connectors (Panel waterproof type)

DF62WP - */*/*/* **EP** - 2.2 **C**

① ② ③ ④ ⑤

①	Series: DF62WP
②	No. of poles: 2~9 "/" Indicates that the connector is a composite connector with a number of poles separated by it.
③	Connector types EP: In-line plug
④	Terminal pitch: 2.2mm
⑤	Shape of connection / terminal C : Crimping case

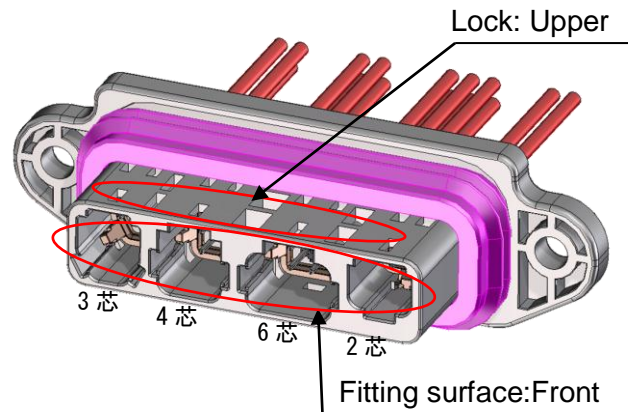

(E.g.) DF62WP-3/4/6/2EP-2.2C
+DF62W-EP2226PCF (Cables attached)

* The order of the number of poles in the product name is from the left side when the lock hole is on the upper side and the fitting hole is on the front side.

Fig.2 DF62WP connector

3. Operation procedure

3-1. Insertion

3-1-a. Positioning for insertion:

Adjust the position for insertion according to the locks of the socket and In-line plug or header.

The mating combination of the socket and In-line plug is shown below.

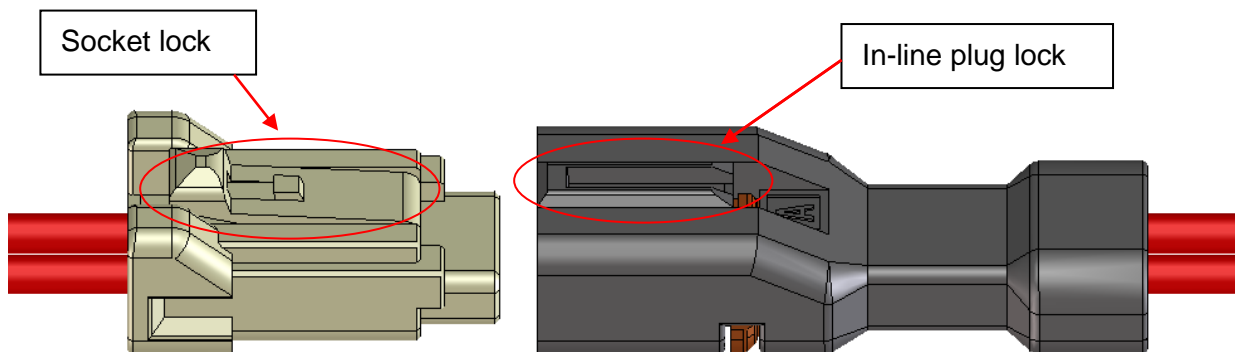

Fig.3 Positioning for insertion

3-1-b. Insertion:

Adjust the position for insertion according to the locks of the socket and In-line plug or header.

The mating combination of Socket and In-line plug is shown below.

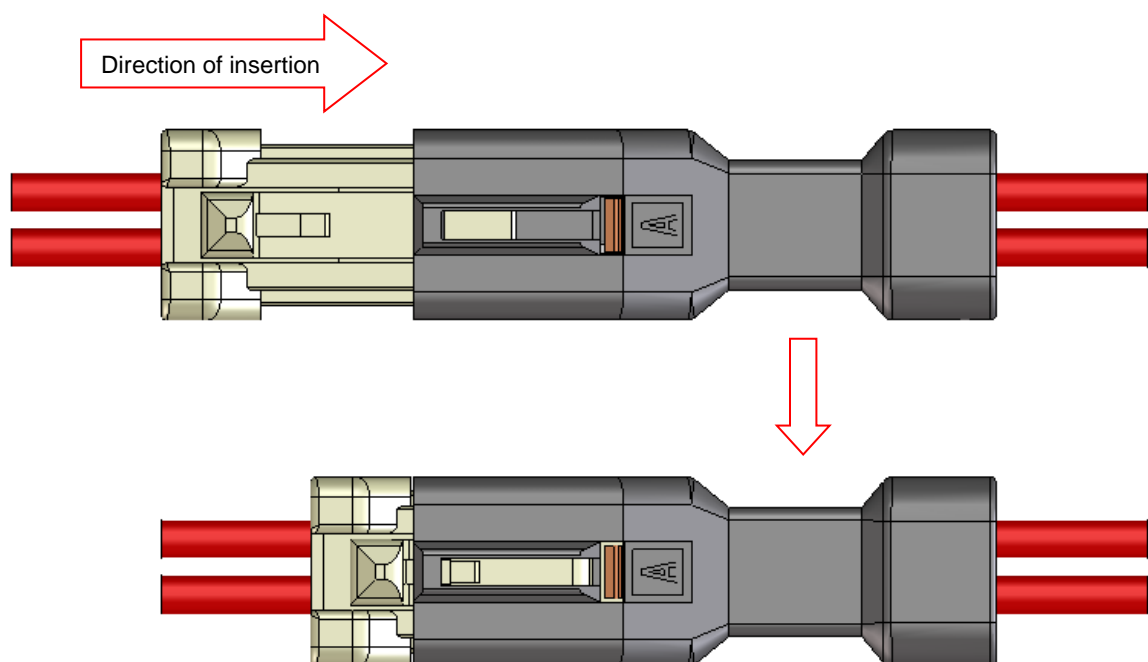

Fig.4 Insertion

To avoid degraded quality, do not tilt the socket for insertion as shown in the figure above.

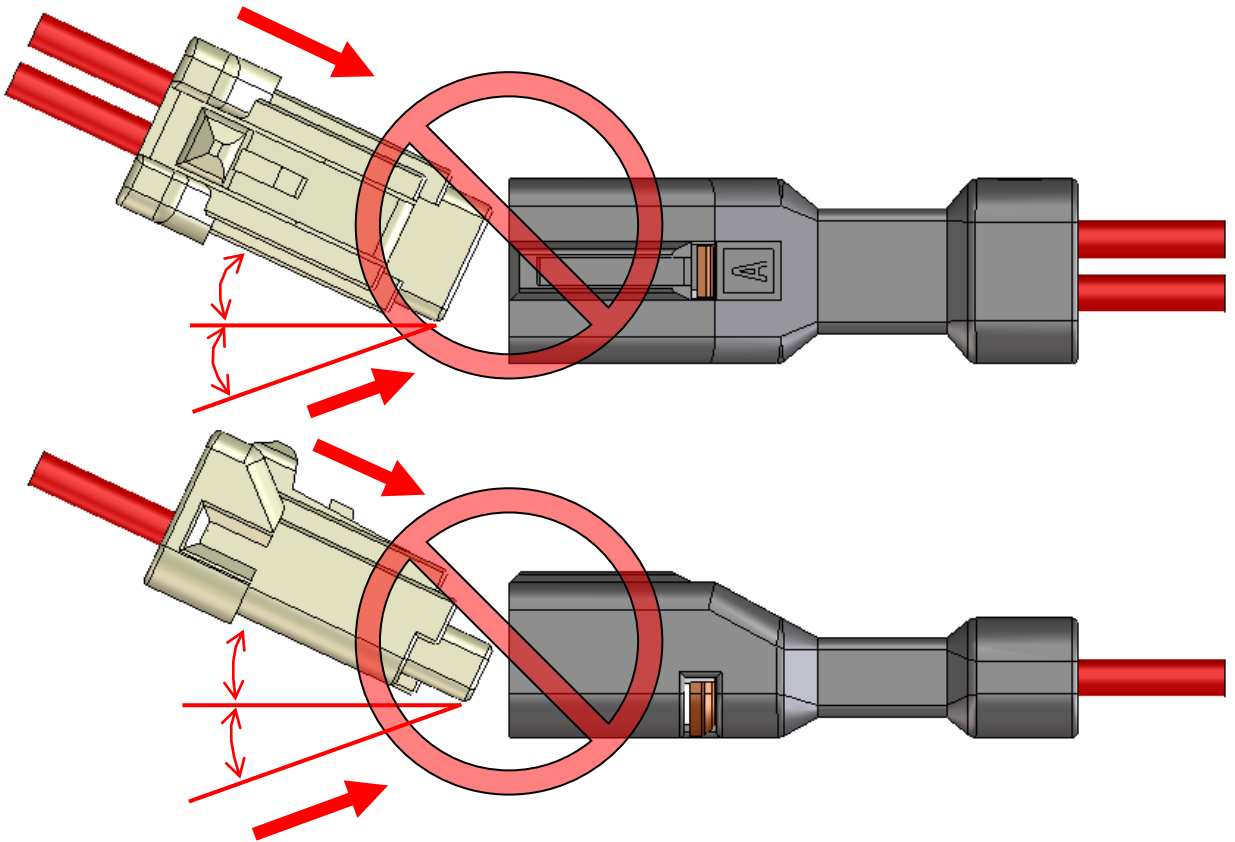

Fig.5 Prohibited insertion



Do not perform mating (different pole mating) between different numbers of poles as there is a risk of terminal buckling and terminal disconnection. Especially when using the DF62WP series (Panel waterproof type), carefully check the arrangement of the number of poles and be careful not to perform different pole fitting.

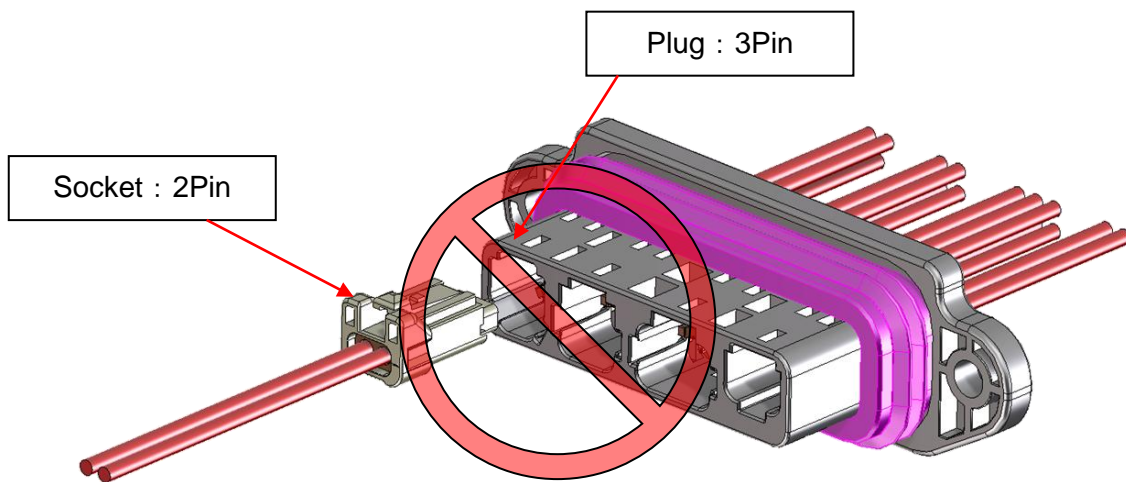

Figure 6. Prohibition insertion method (different pole fitting)

3-1-c. Check fitting:

Make sure the socket has been firmly fit with the In-line plug or header.
 (Check that the socket lock has been caught at the In-line plug or header lock either visually or by slightly pulling a cable by hand.)
 To remove the socket, see 3-2. Socket removal.
 The mating combination of Socket and In-line plug is shown below.

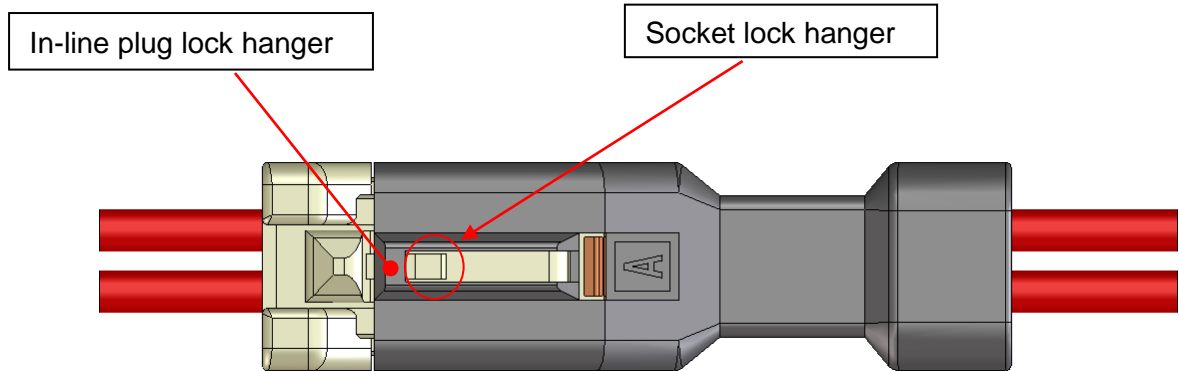

Fig.7 Check fitting

3-2. Socket removal

3-2-a. Removal:

Remove the socket while pressing with a finger the lock spring on the socket to unlock.
 The mating combination of Socket and In-line plug is shown below.

Note: To prevent the lock hanger from being damaged or the cables from being disconnected, do not remove the socket when it is locked.

- * Breaking strength of lock is approx. 30 N when connector is pulled in straight direction. Please avoid excessive force is applied to the connector.
- * Retention force is approx. 7 N / Pin. Please avoid excessive force is applied to particular cable.

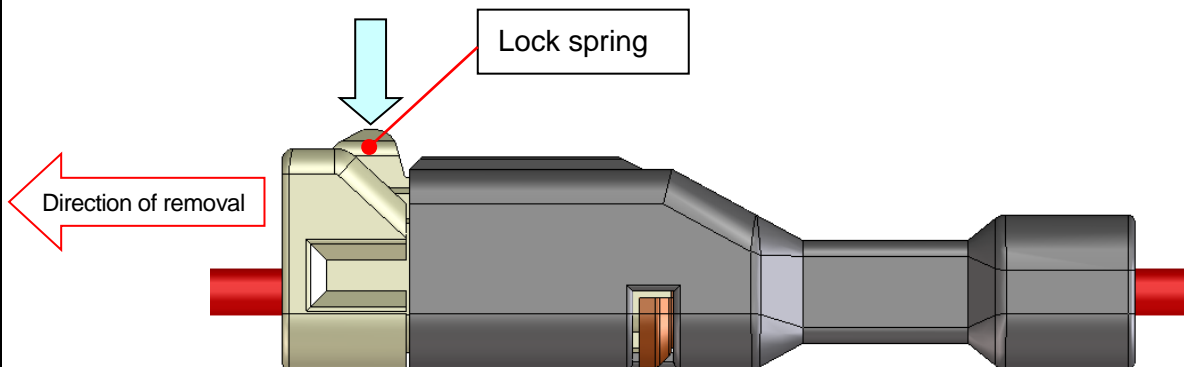

Fig.8 Socket removal

To avoid degraded quality , do not tilt the socket for removal as shown in the figure above.

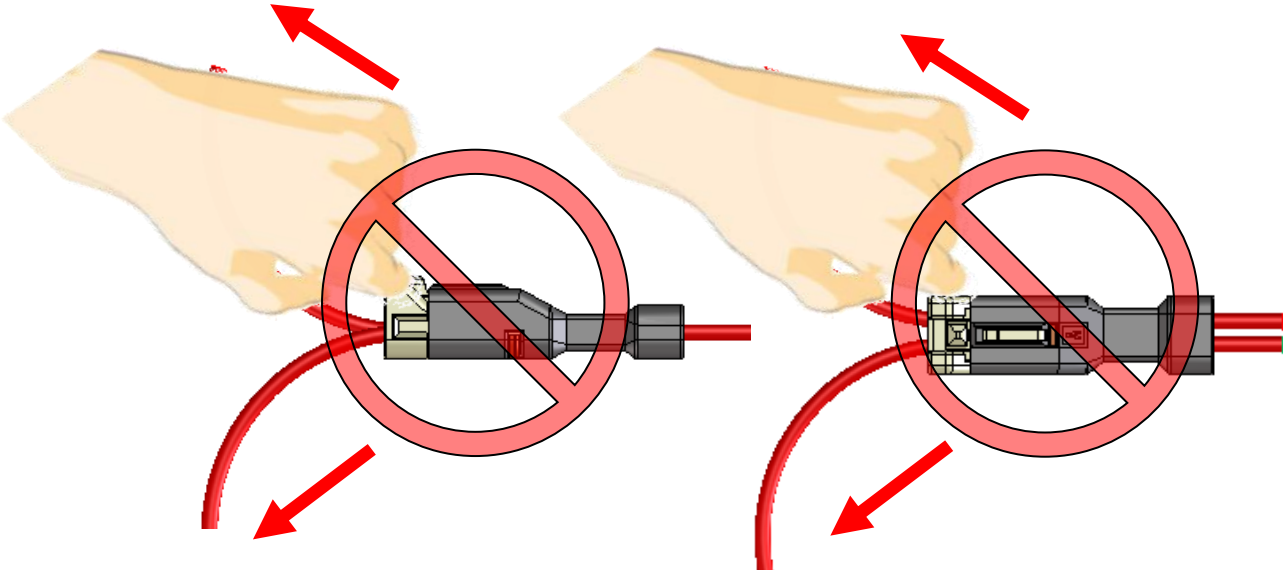

Fig.9 Prohibited removal removal

To avoid degraded quality , do not tilt the socket for removal as shown in the figure above.

4. Notes

- Do not insert or remove the socket while electrifying.
 - Excessive external force applied to connectors could cause failure or damage. Therefore, avoid forced insertion or removal, dropping impact, cable wiring (pull, twist) and such.
 - During cable wiring inside the machine, keep sufficient cable length for slack to avoid direct stress is applied to the connector.
- ⚠
- Forcible wiring such as bending the cable near the connector and straining the cable, could cause contact failure and / or waterproof defect.
 - Check with the cable manufacturer for cable flexibility.



● Cable bending

When bending the cable, provide a straight part from the end face of the connector as shown in the figure below and bend it.

(It depends on the flexibility of the cable, but please bend it at the position of 30 mm as a guide.)

Do not bend sharply from the end face of the connector or stretch the base of the cable because it will put a load on the terminal contact part and the terminal crimping part and cause contact failure and waterproof failure.

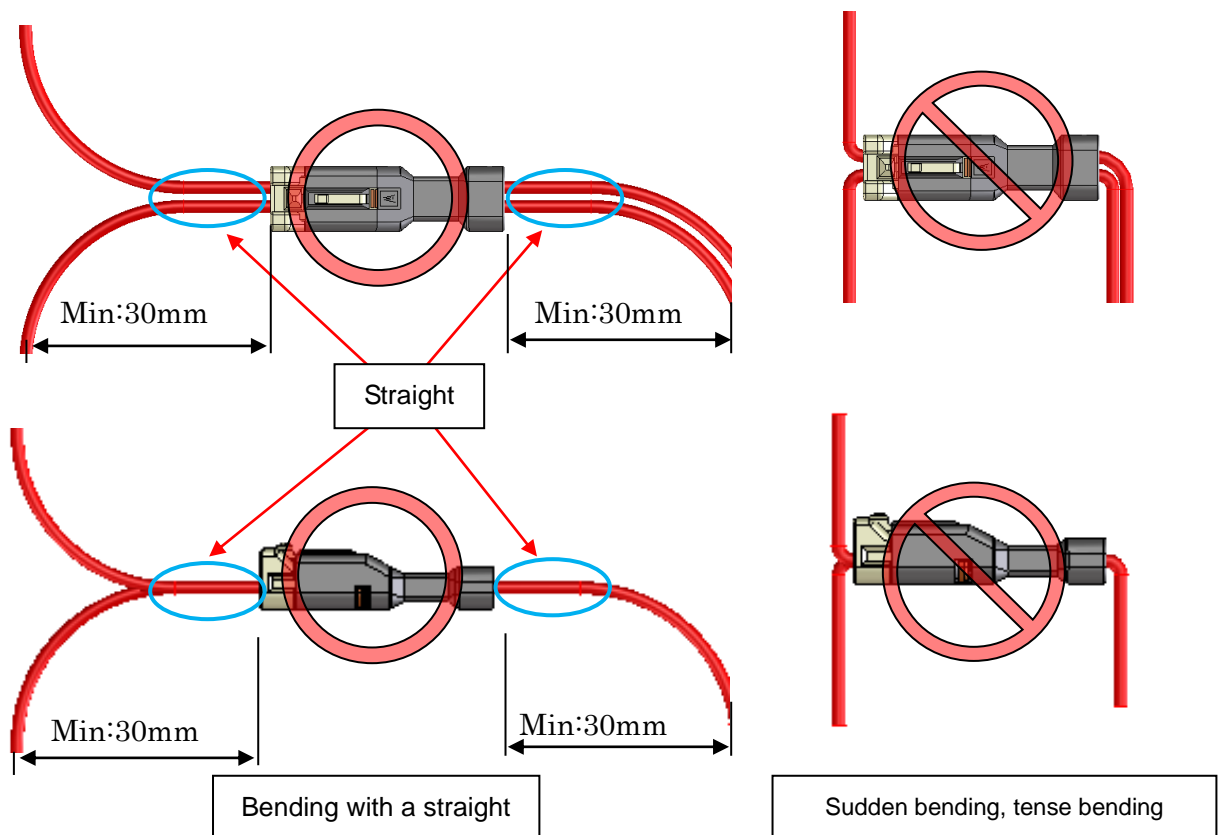

Figure 5-1. Cable bending

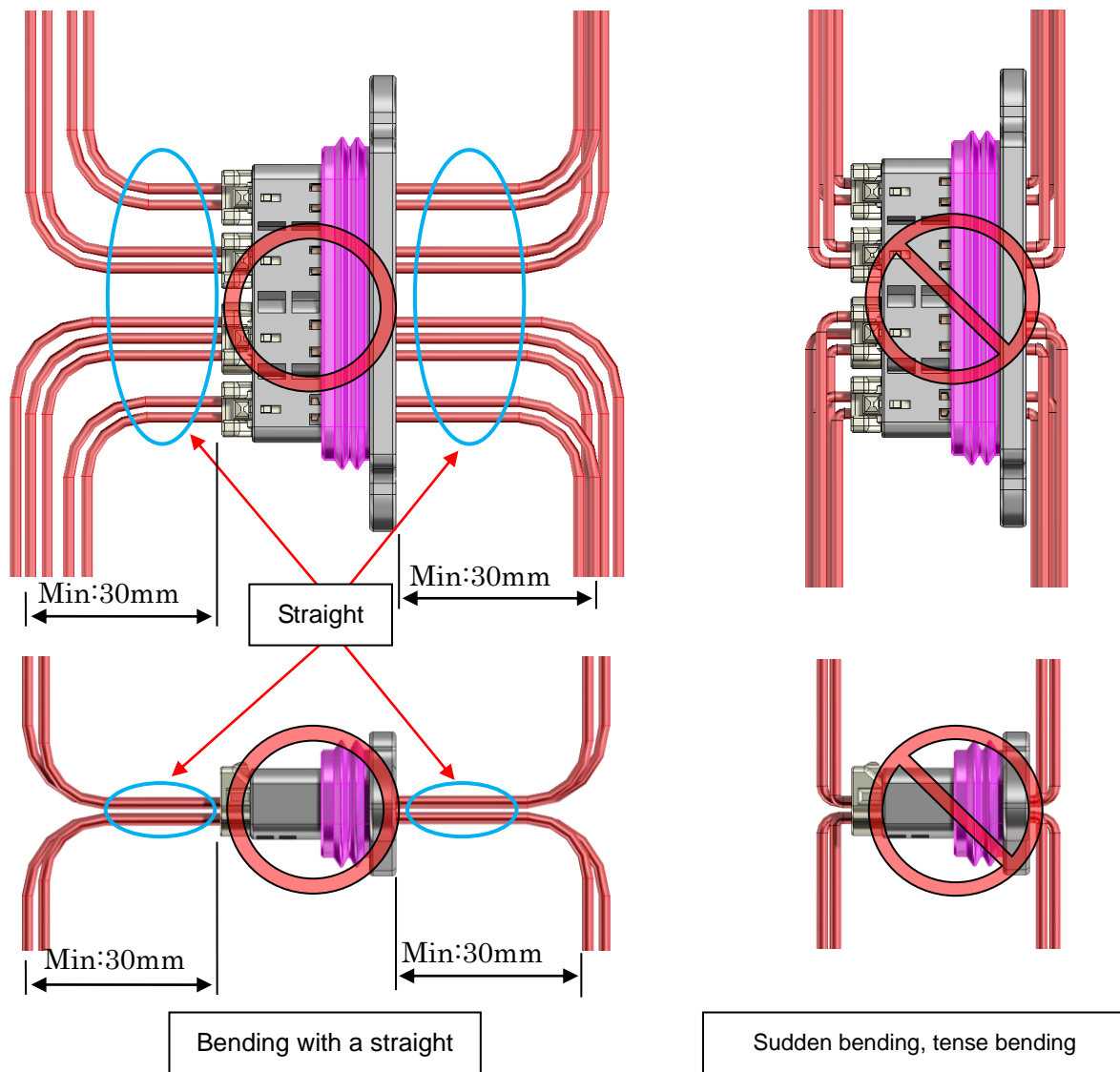

Figure 5-2. Cable bending (DF62WP)

X-ON Electronics

Largest Supplier of Electrical and Electronic Components

Click to view similar products for [Headers & Wire Housings](#) category:

Click to view products by [Hirose](#) manufacturer:

Other Similar products are found below :

[57102-F02-18ULF](#) [58102-G61-06LF](#) [582553-1](#) [009176003701906](#) [01.001.5753.1](#) [0050291907](#) [02.125.8002.8](#) [609-3404](#) [61062-3](#)
[CSU011177004](#) [622-0430](#) [622-3653LF](#) [63453-116](#) [636-1030](#) [636-1427](#) [636-3427](#) [636-4007](#) [641938-9](#) [644827-2](#) [65495-038](#) [65692-001LF](#)
[65781-018](#) [65781-047](#) [65817-010LF](#) [65817-015LF](#) [66207-023LF](#) [67095-007LF](#) [68631-112](#) [68645-018](#) [699319-000](#) [70.362.1628.0](#) [70-4210](#)
[70-4226B](#) [70-4853B](#) [707-5020](#) [707-5028](#) [71.350.2428.0](#) [71961-016LF](#) [733-134](#) [733-162](#) [754199-000](#) [760-3052](#) [800-90-001-10-001000](#)
[801-43-002-10-013000](#) [801-43-006-10-002000](#) [803-41-018-10-001000](#) [803-43-014-20-001000](#) [803-43-024-10-001000](#) [803-93-012-10-001000](#)
[8-1437020-4](#)