

Simple Assembly In-Line Power Connectors for up to 160A

EF1 Series

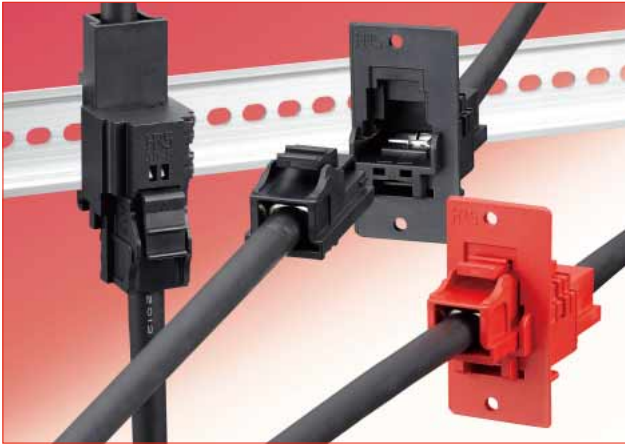

■ Features

1. Simplified assembly

The crimp contact itself becomes the connector in a few simple steps by crimping the contact directly to the power cable and then inserting it into the housing.

2. Quick, snap in lock

Its snap-in structure reduces assembly costs due to its simplicity and ability to reduce wiring steps. This connector does not need screws like traditional terminal block connectors.

3. 160A rated current capacity when using 38mm² cable

Supports 5.5, 8, 14, and 22mm² cables by utilizing a sleeve to convert the conductor diameter to 38mm².

4. Multiple mounting options

Attached to a DIN rail or secured to a panel, this connector is versatile enough to be used in a wide range of mounting applications.

5. Simplified crimp terminations

No special tools are required.

6. Equipped with guide keys

Guide keys are used to prevent incorrect wiring.

7. Pending TÜV, UL certifications

Testing is underway to get this series qualified for various safety standards.

8. RoHS compliant

All materials and substances used to produce this product comply with the RoHS compliant standards.

■ Product Specifications

Ratings	Rated Voltage	AC 1000V, DC 1000V	
	Rated Current (Note 2)	160A (Ambient Temperature 25°C)	38mm ² (2 AWG) cable
	Operating Temperature Range	-25°C to +105°C (Including temperature rise due to current carrying)	
	Storage Temperature Range	-10°C to +60°C	
UL, TÜV	Rated Voltage	AC 600V, DC 600V	
	Rated Current (Note 2)	130A	38mm ² (2 AWG) cable
		94A	22mm ² (4 AWG) cable
		70A	14mm ² (6 AWG) cable
		50A	8mm ² (8 AWG) cable
		40A	5.5mm ² (10 AWG) cable
Operating Temperature Range	-25°C to +105°C (Including temperature rise due to current carrying)		
Storage Temperature Range	-10°C to +60°C		

Note 2 : Please see next page.

Items	Specifications	Conditions
1. Contact Resistance	0.5mΩ max	Measured with DC 1A
2. Insulation Resistance	1,000MΩ min	Measured with DC 500V
3. Withstanding Voltage	No flashover or breakdown	AC 3310V for 1 minute
5. Durability	1) Contact Resistance : 1mΩ max 2) Inserting and Extracting Force : 150N max	30 mating cycles
6. Temperature Cycles	Insulation Resistance : 1,000MΩ min	-55°C : 30 minutes → Room temperature : 2 to 3 minutes → 105°C : 30 minutes → Room temperature : 2 to 3 minutes 5 cycles
7. Salt Water Spray	Should not have functional problems	5% concentration of salt water, left for 48 hours
8. Humidity resistance (steady state)	Insulation Resistance : 10MΩ min (in high humidity) 100MΩ min (dry)	Temperature 40°C, humidity 90 to 95%, 96 hours

Note : Operating temperature range includes the temperature rise by current carrying.

[Reference] Derating curve and temperature rise curve

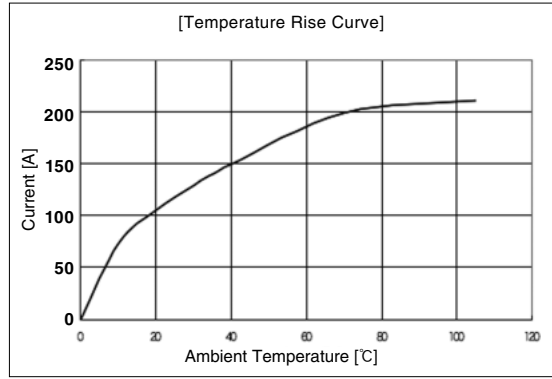
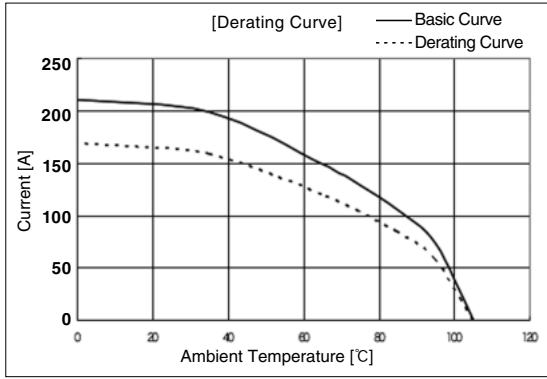

Note 1 : The derating curve is derived from the basic curve multiplied by the derating factor of 0.8.

Note 2 : The value of rated current varies with the ambient temperature. It is recommended to use the product within the derating curve zone.

When using a UL or TÜV approved product, please use the product within the specified range as well as the derating curve area.

Note 3 : The measurement method of the derating curve and temperature rise curve is shown below.

- Test specimen : This product, unused prior to testing.
- Test cable conductor cross sectional area : 2 AWG (38mm²)
- Test condition : Power supplied while the specimen is in a stationary state and then measured.

■ Material / Finish

Component	Material	Finish	Remarks
Insulator	PBT resin	Black or Red or Blue	UL94V-0
Contact Spring	Copper alloy	Tin plated	_____
Contact			_____
Sleeve			_____

■ Product Number Structure

Refer to the chart below when determining the product specifications from the product number. Please select from the product numbers listed in this catalog when placing orders.

● Connector

EF 1 - 38 R A - 1 S C A ()**

① ② ③ ④ ⑤ ⑥ ⑦ ⑧ ⑨

● Sleeve

EF 1 - 38 - 22 ()**

① ② ⑩ ⑨

① Series Name : EF1	⑥ Contact Structure : S = Spring contact side P = Non-spring contact side
② Contact Size : 38 = 38-5 size contact	
③ Connector Type : P = Plug R = Receptacle None = Sleeve	⑦ Contact Termination Method : C = Crimp termination
	⑧ Mating Guide Display : 4 different keying options available from A to D
	⑨ Other specification differences are noted with (01), (02)... to distinguish certain variations.
④ Serial Symbol	⑩ Supported Cables 22 = Supports an equivalent cable with 22mm ² conductor cross section area 14 = Supports an equivalent cable with 14mm ² conductor cross section area 8 = Supports an equivalent cable with 5.5 and 8mm ² conductor cross section area
⑤ No. of Contacts : 1	

■ Receptacle (DIN rail mount type)

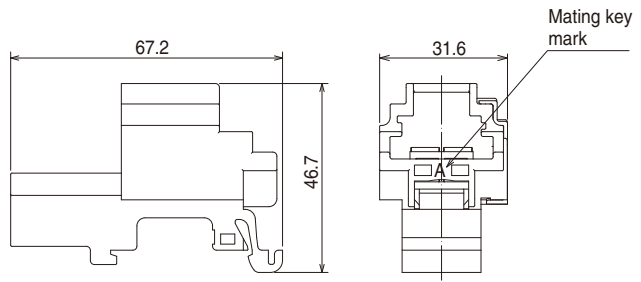

Unit : mm

Part No.	HRS No.	Remarks
EF1-38R-1SCA(20)	142-0001-3 20	
EF1-38R-1SCB(20)	142-0009-5 20	
EF1-38R-1SCC(20)	142-0011-7 20	
EF1-38R-1SCD(20)	142-0013-2 20	

■ Receptacle (panel mount type)

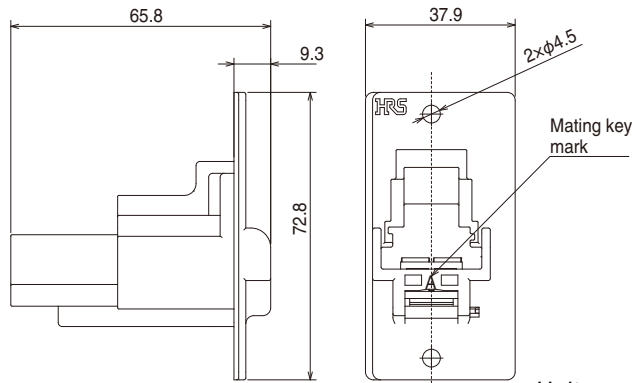

Unit : mm

Part No.	HRS No.	Remarks
EF1-38RA-1SCA(20)	142-0003-9 20	
EF1-38RA-1SCA(30)	142-0003-9 30	Color : Red
EF1-38RA-1SCB(20)	142-0004-1 20	
EF1-38RA-1SCB(31)	142-0004-1 31	Color : Blue
EF1-38RA-1SCC(20)	142-0015-8 20	
EF1-38RA-1SCD(20)	142-0016-0 20	
EF1-38RA-1SCD(30)	142-0016-0 30	Color : Red

■ Plug

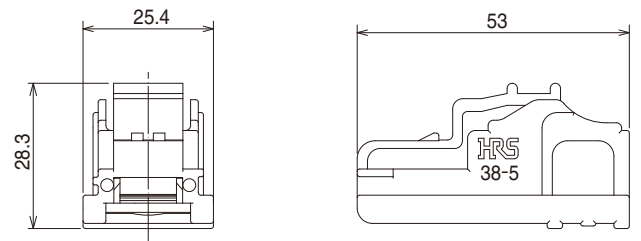

Unit : mm

Part No.	HRS No.	Remarks
EF1-38P-1PCA	142-0002-6 00	
EF1-38P-1PCA(10)	142-0002-6 10	Color : Red
EF1-38P-1PCB	142-0005-4 00	
EF1-38P-1PCC	142-0010-4 00	
EF1-38P-1PCD	142-0012-0 00	

■ Sleeve

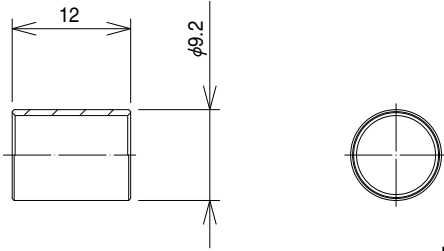

Unit : mm

Part No.	HRS No.	Conductor cross section area of applicable electric wires	Rated Current
EF1-38-22	142-0006-7	22mm ²	94A
EF1-38-8	142-0007-0	① 8mm ² , ② 5.5mm ²	① 50A, ② 40A
EF1-38-14	142-0008-2	14mm ²	70A

◆ Tools

● Recommended Crimp Tools

HT111/9H-60



HT112/REC-150F



Note : Please perform regular maintenance on your crimp tool according to its instruction manual.

Tool/Jig	Part No.	HRS No.	Remarks
Manual hydraulic type crimp tool	HT111/9H-60	902-1515-2	Equivalent product : 9H-60 made by IZUMI Product Company
Electric hydraulic type crimp tool	HT112/REC-150F	902-1516-5	Equivalent product : REC-150F made by IZUMI Product Company

◆ Panel Cut-Out Dimensions

Single Mounting

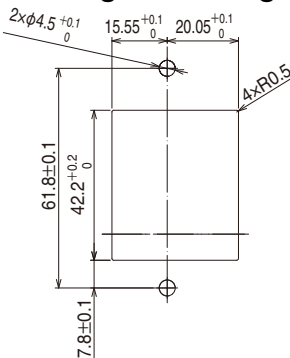

Multiple Mounting

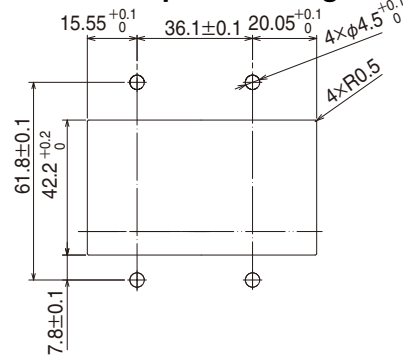

◆ Safety Precautions

⚠ Warning

- Do not touch the exposed conductor while it is energized, failing to follow this warning may cause an electric shock and injury. ⚠
- The power should be in the OFF position when inserting or extracting this connector.
- After mating this connector, perform a light pull on the cable to ensure that it has been correctly mated and the locking process will hold it in place. If it is not mated correctly, then the cable will be removed. An incomplete mate can cause disconnection, contact failure and a significant danger threat.

⚠ Caution

- This connector was designed to be used in a stable and stationary environment, do not try to operate this connector where vibrations will occur.
- Please only use Hirose approved contacts, using unapproved contacts can result in a lowering of the product's performance and cause a serious accident. Please contact your local Hirose representative for additional information.



HIROSE ELECTRIC CO.,LTD.

2-6-3,Nakagawa Chuoh,Tsuzuki-Ku,Yokohama-Shi 224-8540,JAPAN
 TEL: +81-45-620-3526 Fax: +81-45-591-3726
<http://www.hirose.com>
<http://www.hirose-connectors.com>

X-ON Electronics

Largest Supplier of Electrical and Electronic Components

Click to view similar products for [Heavy Duty Power Connectors](#) category:

Click to view products by [Hirose](#) manufacturer:

Other Similar products are found below :

[1424439](#) [1424438](#) [09330062652](#) [605601-1](#) [6340G1](#) [6341G1](#) [6360G1](#) [6373G1](#) [6374g2](#) [6396G1](#) [647757-1](#) [6643411-1](#) [6646058-2](#) [6646137-1](#)
[6646138-1](#) [6646348-1](#) [6646479-1](#) [6646608-1](#) [6646786-1](#) [6646940-1](#) [6651525-1](#) [6651529-1](#) [6651778-1](#) [6651788-1](#) [696465-1](#) [696475-1](#)
[73000005059](#) [73000005349](#) [73000005642](#) [73080965046](#) [765-15-0080A](#) [765-16-0080B](#) [789.700-44](#) [789.700-54](#) [80-1010](#) [80-9](#) [827381-1](#)
[829992-1](#) [902-77-02113](#) [PL00U-301-10D10](#) [PM103MOOLOO](#) [PM212MOOLOO](#) [PM309FOOLOO](#) [PM324FOOLCH](#) [PMHPAF11S03](#)
[PMHPAF14S01](#) [PMHPAM14P05](#) [PMHPAS06](#) [PMHPBF14S01](#) [PP45PC12S](#)