

Jan.1.2022 Copyright 2022 HIROSE ELECTRIC CO., LTD. All Rights Reserved.
In case of consideration for using Automotive equipment / device which demand high reliability, kindly contact our sales window correspondents.

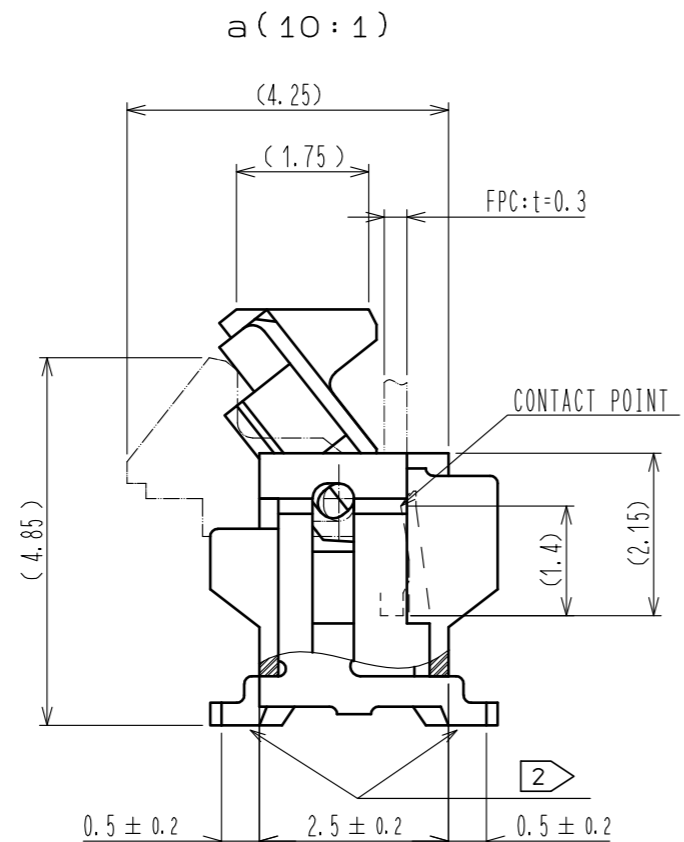
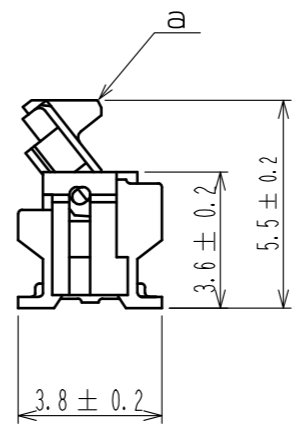
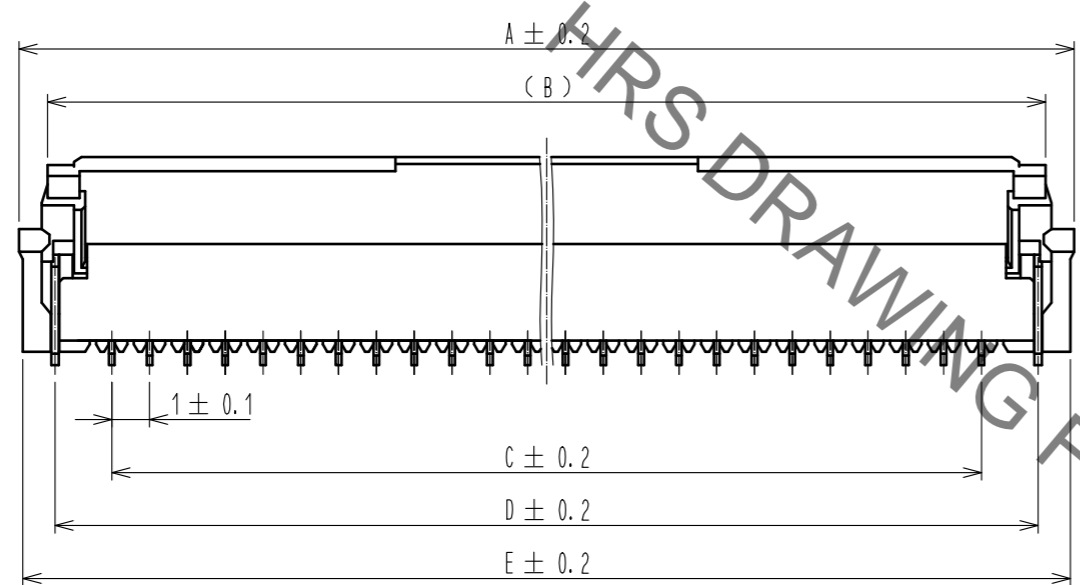
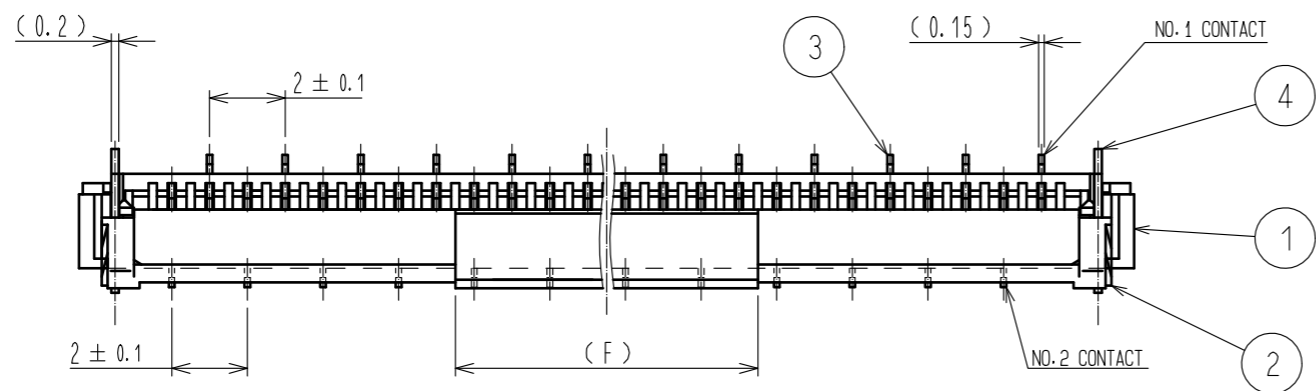

- NOTE 1 THE DIMENSIONS IN PARENTHESES ARE FOR REFERENCE.
 2 LEAD CO-PLANARITY SHALL BE 0.1 MAX.
 3 SEE DIMENSION TABLE IN THE APPENDIX.
 4 DIFFERENCES OF THE GOLD PLATED AREA DO NOT INFLUENCE ON THE PRODUCT PERFORMANCE.
 5 'n' REPRESENTS THE NUMBER OF CONTACTS.

HRS DRAWING FOR REFERENCE

3	PHOSPHOR BRONZE	(CONTACT AREA, LEAD) GOLD PLATING 0.05μMIN OVER NICKEL 1μMIN (OTHER) NICKEL PLATING 1μMIN	8 (CONNECTOR) 7 POLYSTYRENE 6 POLYESTER				
2	PPS	(DEEP BROWN) UL94V-0	5 POLYSTYRENE				
1	PA	(BEIGE) UL94V-0	4 BRASS TIN PLATING 1μMIN OVER NICKEL 1μMIN.				
NO.	MATERIAL	FINISH . REMARKS	NO. MATERIAL FINISH . REMARKS				
UNITS mm		SCALE 5 : 1	COUNT 7	DESCRIPTION OF REVISIONS DIS-F-00004925	DESIGNED SE. YOKOYAMA	CHECKED HS. SAKAMOTO	DATE 20190718
HRS HIROSE ELECTRIC CO., LTD.		APPROVED : NF. MIYAZAKI 20150916	DRAWING NO. EDC-366184-00-00	CHECKED : HS. SAKAMOTO 20150915	PART NO. FH12- ** S-1SVA(54)		
		DESIGNED : SG. MASAKI 20150915	CODE NO. CL586	DRAWN : SG. MASAKI 20150915	1/5		

Jan.1.2022 Copyright 2022 HIROSE ELECTRIC CO., LTD. All Rights Reserved.
In case of consideration for using Automotive equipment / device which demand high reliability, kindly contact our sales window correspondents.

RECOMMENDED PCB MOUNTING PATTERN

NUMBER OF CONTACTS: EVEN NUMBER

NUMBER OF CONTACTS: ODD NUMBER

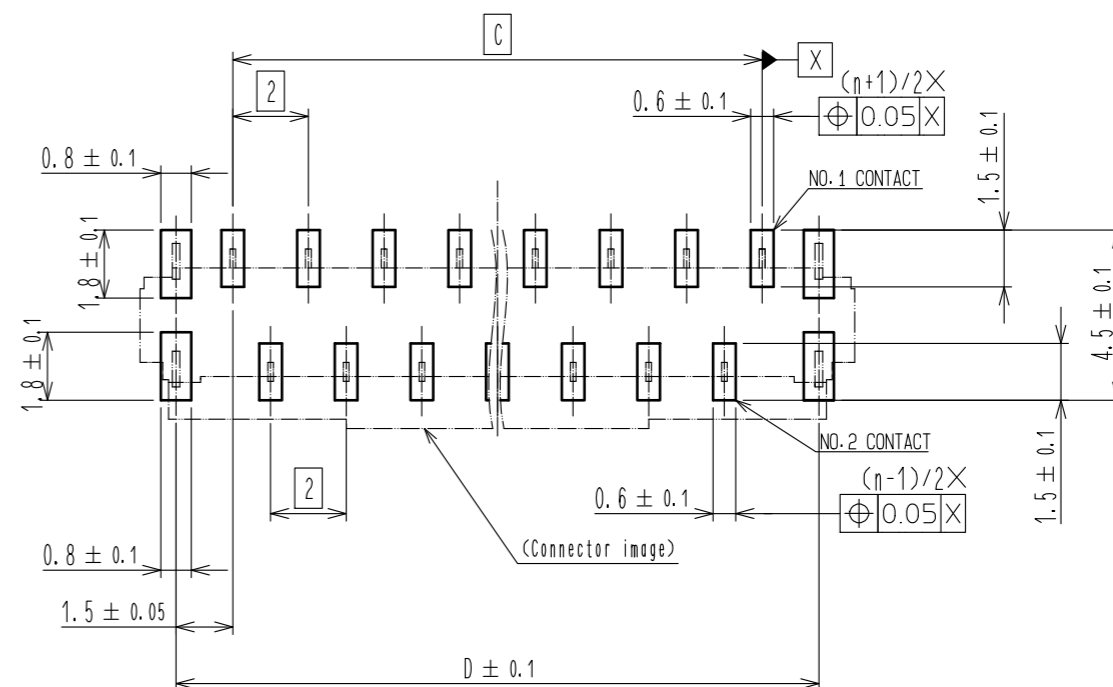
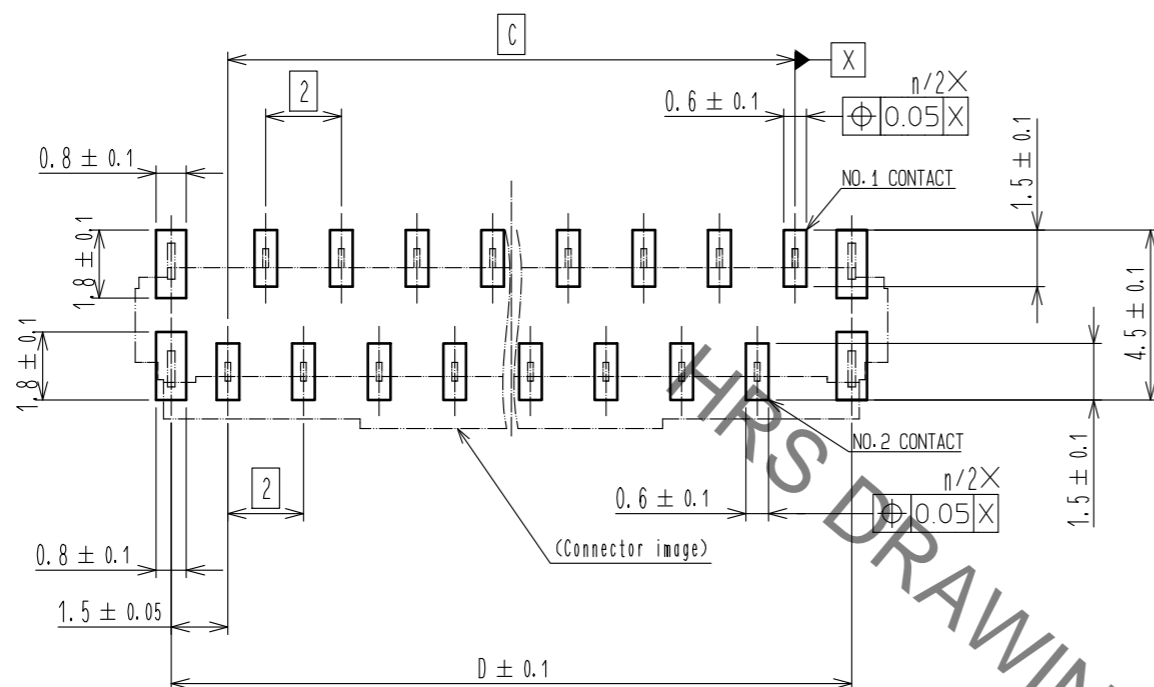

RECOMMENDED STENCIL PATTERN (RECOMMENDED STENCIL THICKNESS: t=0.15)

NUMBER OF CONTACTS: EVEN NUMBER

NUMBER OF CONTACTS: ODD NUMBER

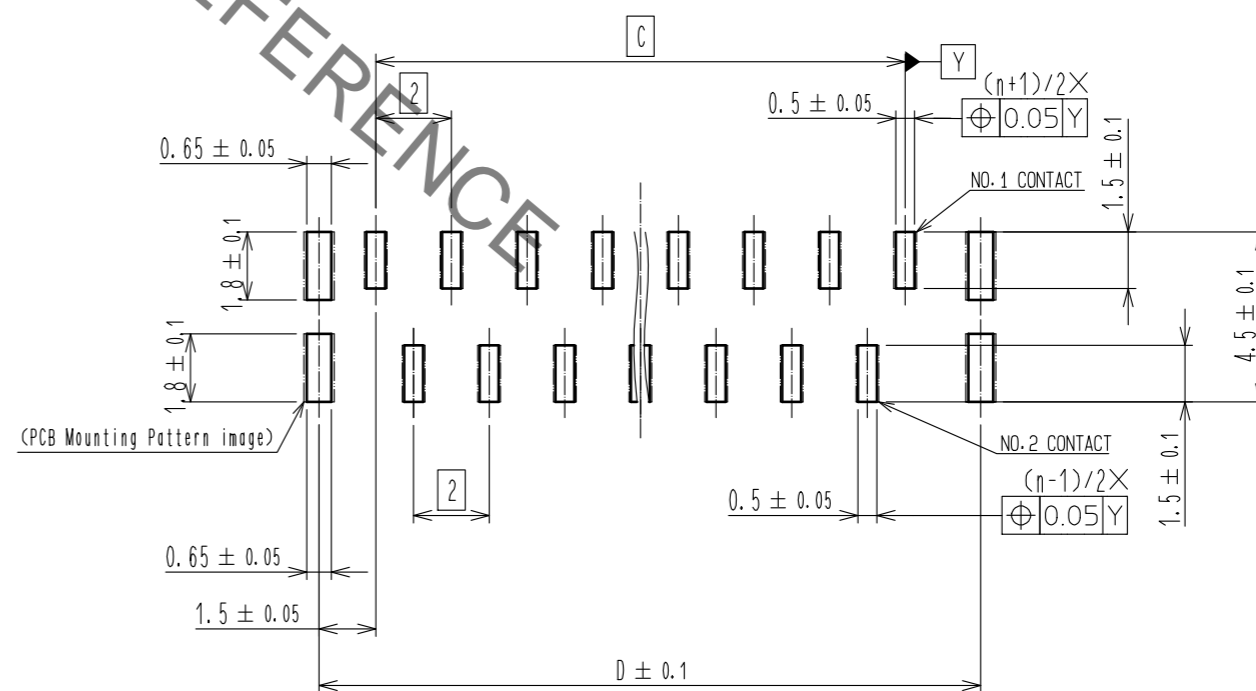
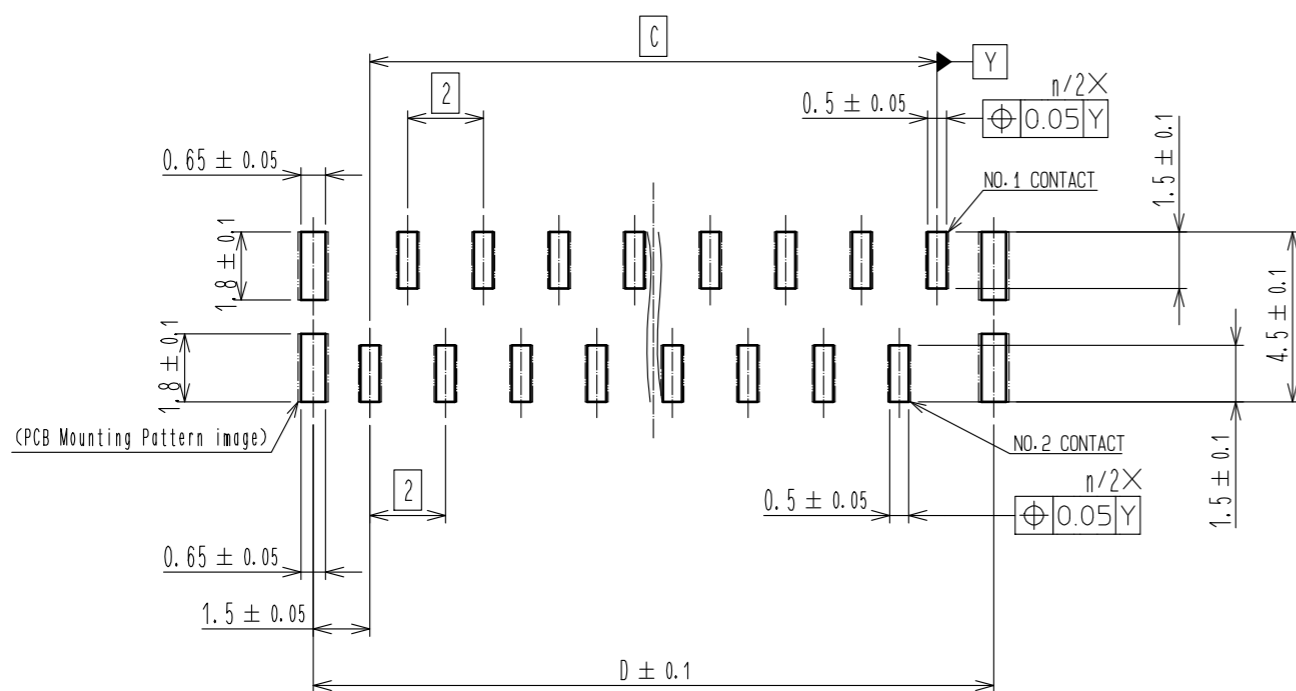

HRS	DRAWING NO.	EDC-366184-00-00
	PART NO.	FH12-***S-1SVA(54)
	CODE NO.	CL586
		2/5

Jan.1.2022 Copyright 2022 HIROSE ELECTRIC CO., LTD. All Rights Reserved.
In case of consideration for using Automotive equipment / device which demand high reliability, kindly contact our sales window correspondents.

RECOMMENDED FPC/FFC (15:1)

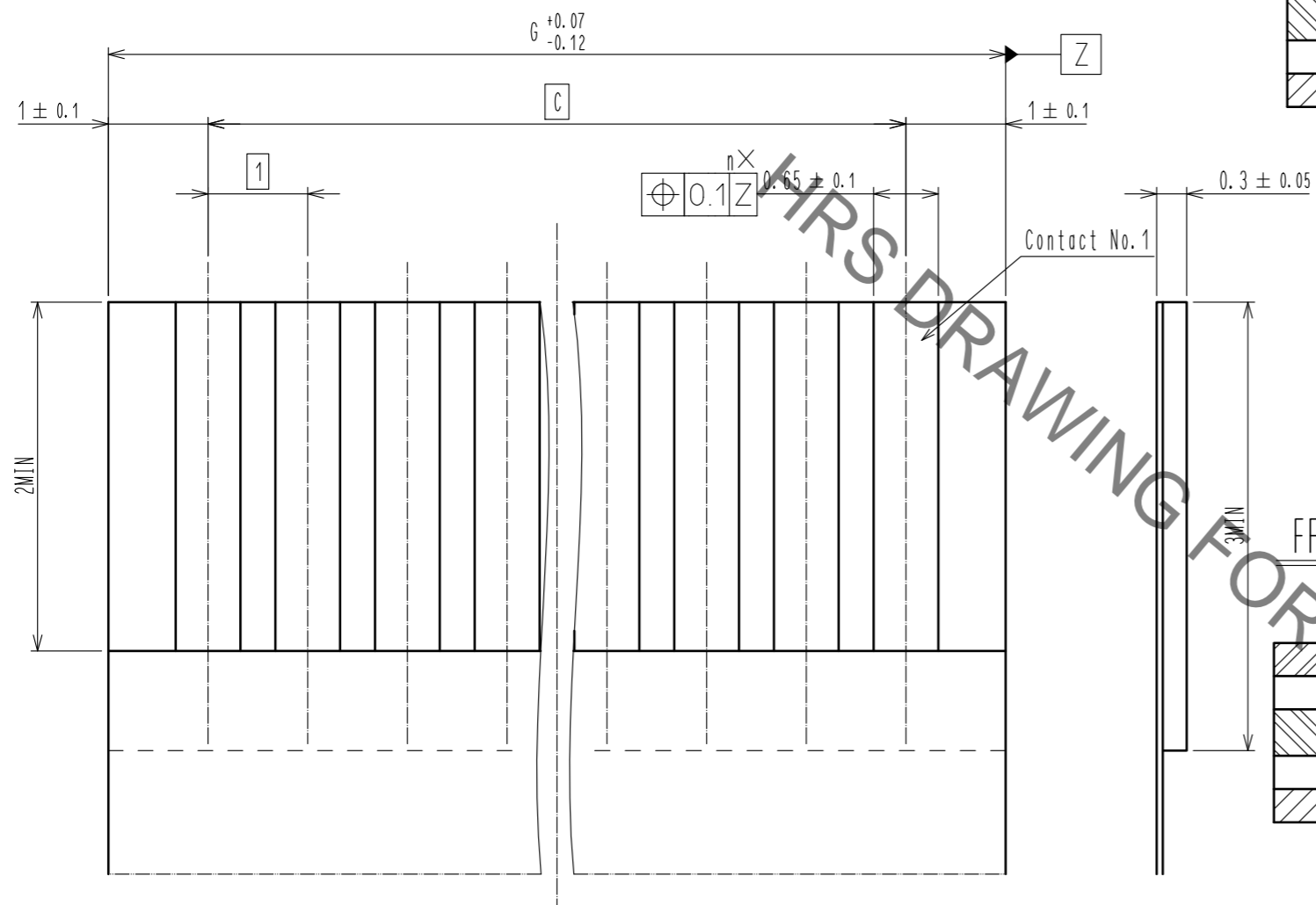

FPC CONFIGURATION (REFERENCE EXAMPLE) (SCALE:FREE)

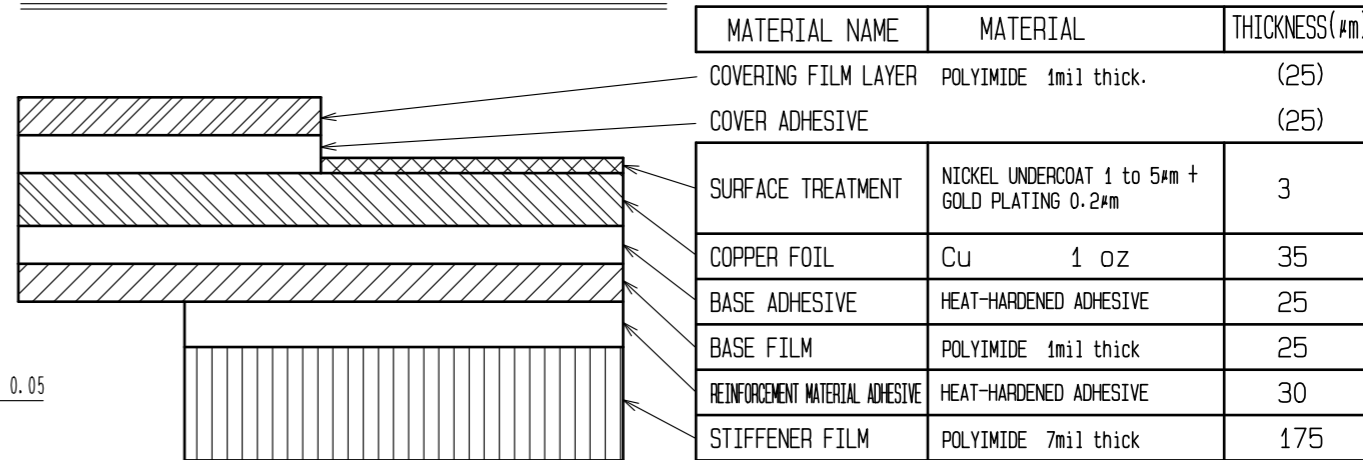

MATERIAL NAME	MATERIAL	THICKNESS(μm)
COVERING FILM LAYER	POLYIMIDE 1mil thick.	(25)
COVER ADHESIVE		(25)
SURFACE TREATMENT	NICKEL UNDERCOAT 1 to 5μm + GOLD PLATING 0.2μm	3
COPPER FOIL	CU 1 oz	35
BASE ADHESIVE	HEAT-HARDENED ADHESIVE	25
BASE FILM	POLYIMIDE 1mil thick	25
REINFORCEMENT MATERIAL ADHESIVE	HEAT-HARDENED ADHESIVE	30
STIFFENER FILM	POLYIMIDE 7mil thick	175

FFC CONFIGURATION (REFERENCE EXAMPLE) (SCALE:FREE)

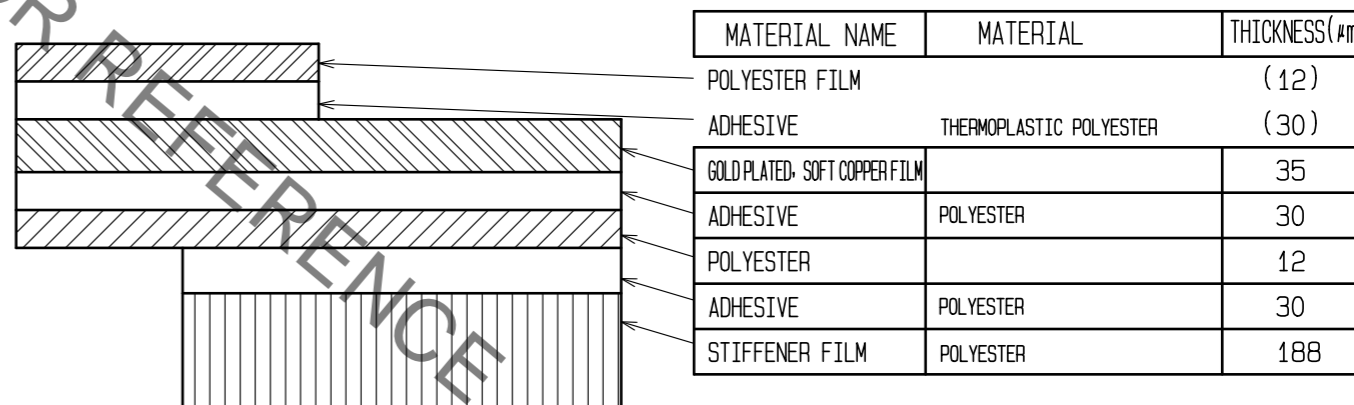

MATERIAL NAME	MATERIAL	THICKNESS(μm)
POLYESTER FILM		(12)
ADHESIVE	THERMOPLASTIC POLYESTER	(30)
GOLD PLATED SOFT COPPER FILM		35
ADHESIVE	POLYESTER	30
POLYESTER		12
ADHESIVE	POLYESTER	30
STIFFENER FILM	POLYESTER	188



DRAWING NO.	EDC-366184-00-00
PART NO.	FH12-***S-1SVA(54)
CODE NO.	CL586

3/5

Jan.1.2022 Copyright 2022 HIROSE ELECTRIC CO., LTD. All Rights Reserved.
In case of consideration for using Automotive equipment / device which demand high reliability, kindly contact our sales window correspondents.

EMBOSSED CARRIER TAPE DIMENSION (2:1)

TAPE WIDTH : 32mm MIN

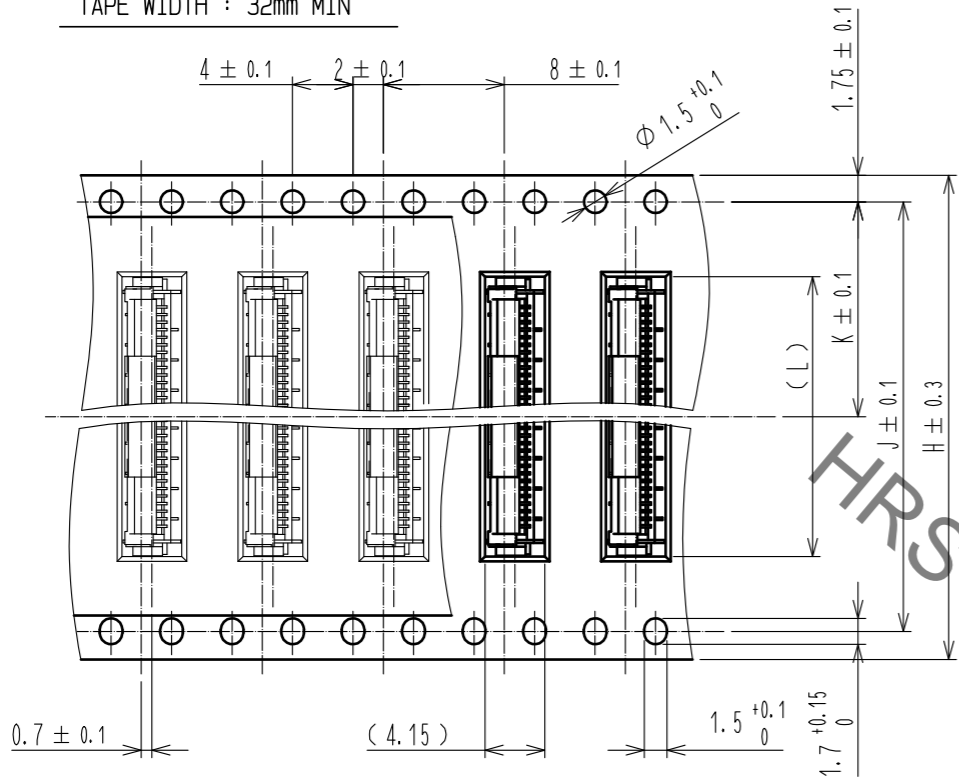

DIRECTION OF UNREELING

TAPE WIDTH : 24mm MAX

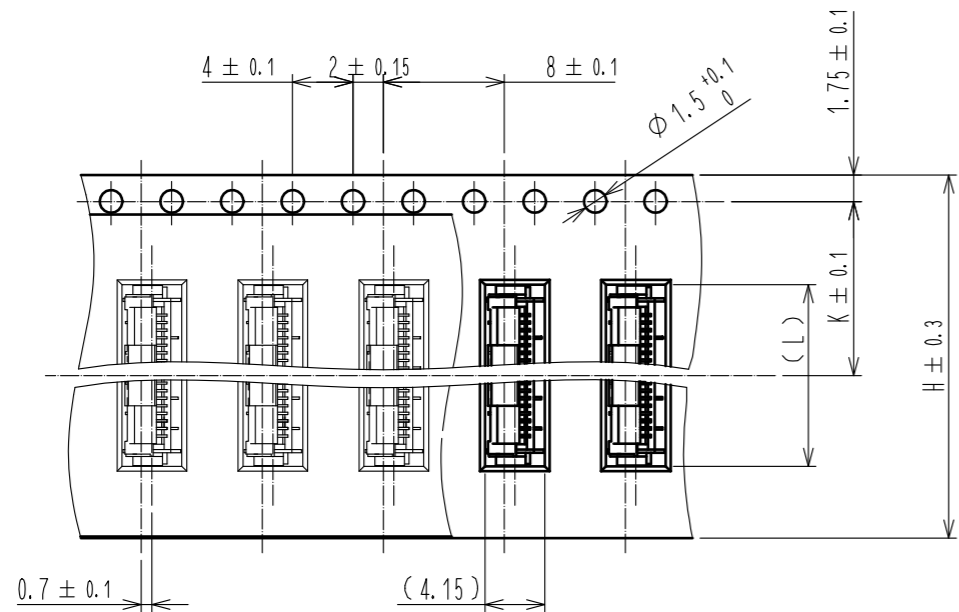

DIRECTION OF UNREELING

REEL DIMENSION(SHOW AS BELOW)(FREE)

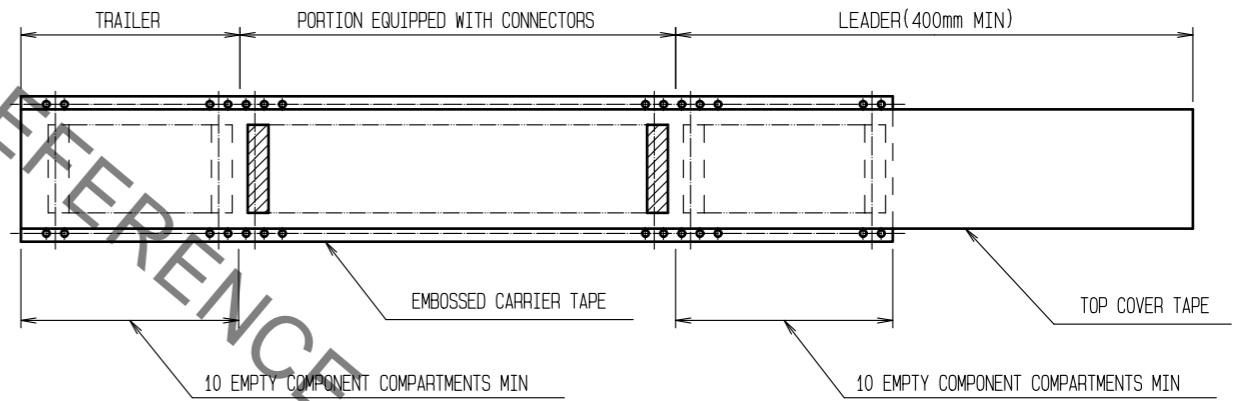
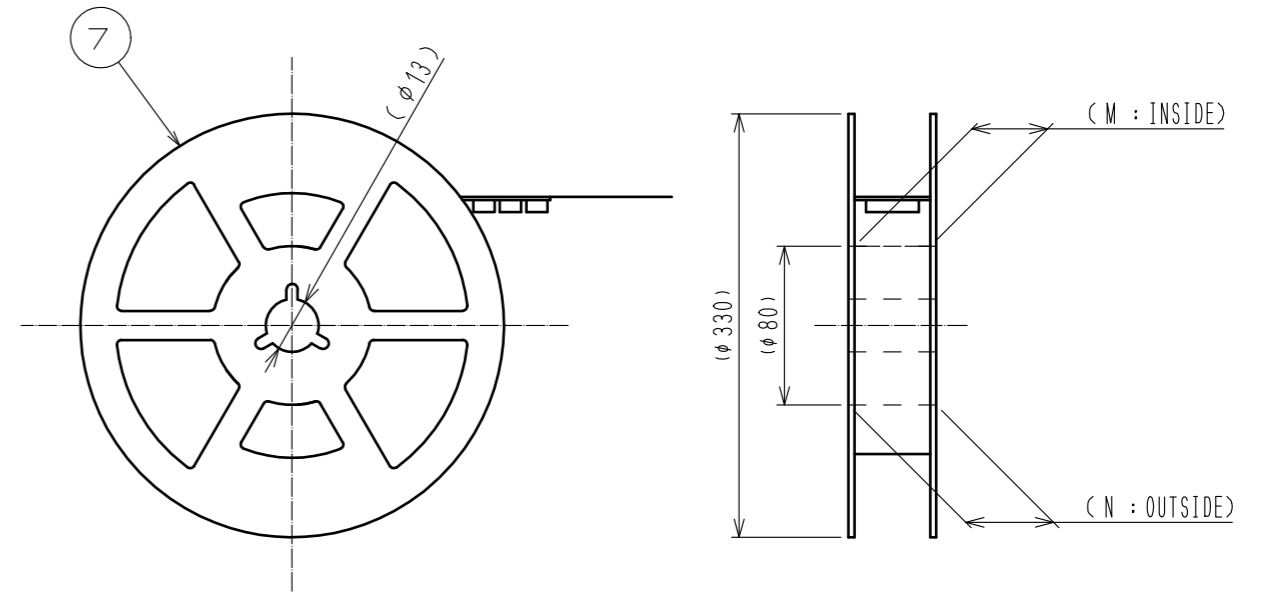

NOTE 6 1REEL : 1000 CONNECTORS.

HRS DRAWING FOR REFERENCE

DRAWING FOR PACKING



DRAWING NO.	EDC-366184-00-00
PART NO.	FH12-***S-1SVA(54)
CODE NO.	CL586

4/5

Jan.1.2022 Copyright 2022 HIROSE ELECTRIC CO., LTD. All Rights Reserved.
 In case of consideration for using Automotive equipment / device which demand high reliability, kindly contact our sales window correspondents.

	PART NO.	CODE NO.	NUMBER OF CONTACTS	DIMENSION TABLE OF CONNECTOR, FPC, FFC, PCB MOUNTING PATTERN AND STENCIL PATTERN							DIMENSION TABLE OF DRAWING FOR PACKING					
				A	B	C	D	E	F	G	H	J	K	L	M	N
△	FH12- 6S-1SVA(54)	CL586-0822-0-54	6	9.9	8.4	5	8	9.7	4	7	24	—	11.5	10	25.4	29.4
△	FH12- 7S-1SVA(54)	CL586-0823-0-54	7	10.9	9.4	6	9	10.7	4	8	24	—	11.5	11	25.4	29.4
△	FH12- 8S-1SVA(54)	CL586-0824-0-54	8	11.9	10.4	7	10	11.7	4	9	24	—	11.5	12	25.4	29.4
△	FH12-16S-1SVA(54)	CL586-0825-0-54	16	19.9	18.4	15	18	19.7	8	17	32	28.4	14.2	20	33.4	37.4
△	FH12-20S-1SVA(54)	CL586-0826-0-54	20	23.9	22.4	19	22	23.7	8	21	44	40.4	20.2	24	45.4	49.4
△	FH12-22S-1SVA(54)	CL586-0827-0-54	22	25.9	24.4	21	24	25.7	8	23	44	40.4	20.2	26	45.4	49.4
△	FH12-24S-1SVA(54)	CL586-0828-0-54	24	27.9	26.4	23	26	27.7	8	25	44	40.4	20.2	28	45.4	49.4

THIS DRAWING FOR REFERENCE

HRS	DRAWING NO.	EDC-366184-00-00
	PART NO.	FH12-**S-1SVA(54)
	CODE NO.	CL586

X-ON Electronics

Largest Supplier of Electrical and Electronic Components

Click to view similar products for [FFC & FPC Connectors](#) category:

Click to view products by [Hirose](#) manufacturer:

Other Similar products are found below :

[K-FC20](#) [FH29B-80S-0.2SHW\(99\)](#) [FPH-2022G](#) [AYF332735](#) [52610-1075](#) [52610-1275](#) [52610-1934](#) [501864-3091-TR225](#) [086222026001800](#)
[52610-0675](#) [62684-36210E9ALF](#) [52746-1671-TR250](#) [10051922-2810EHLF](#) [6-520415-9](#) [SFV6R-1STE9HLF](#) [XF3M-2915-1B-R100](#)
[1658549-1](#) [46214008010800](#) [AYF534065TA](#) [AYF351525](#) [086212040340800+](#) [AYF530365TA](#) [67000-014LF](#) [67000-004LF](#)
[006207341915000+](#) [DS1020-19RT1D](#) [67000-003LF](#) [67000-011LF](#) [67000-016LF](#) [HFW14R-2STE9LF](#) [SFV32R-2STBE9HLF](#) [SFW12R-](#)
[5STE9LF](#) [SFW18R-1STAE9LF](#) [SFW4R-5STE9LF](#) [52807-0430](#) [046283021002868+](#) [THD1015-8CL-SN](#) [67000-006LF](#) [502250-8027](#)
[104267-9617](#) [66987-011LF](#) [AYF362535](#) [F0501-T-50-20T-R](#) [HFW8S-2STAE1HLF](#) [67000-008LF](#) [67000-012LF](#) [ECC576069EU](#) [F1002-B-](#)
[20-20T-R](#) [HFW15S-2STAE1HLF](#) [0781271110](#)