

DRAWING FOR REFERENCE: This is subject to change without notice
08/11/2012

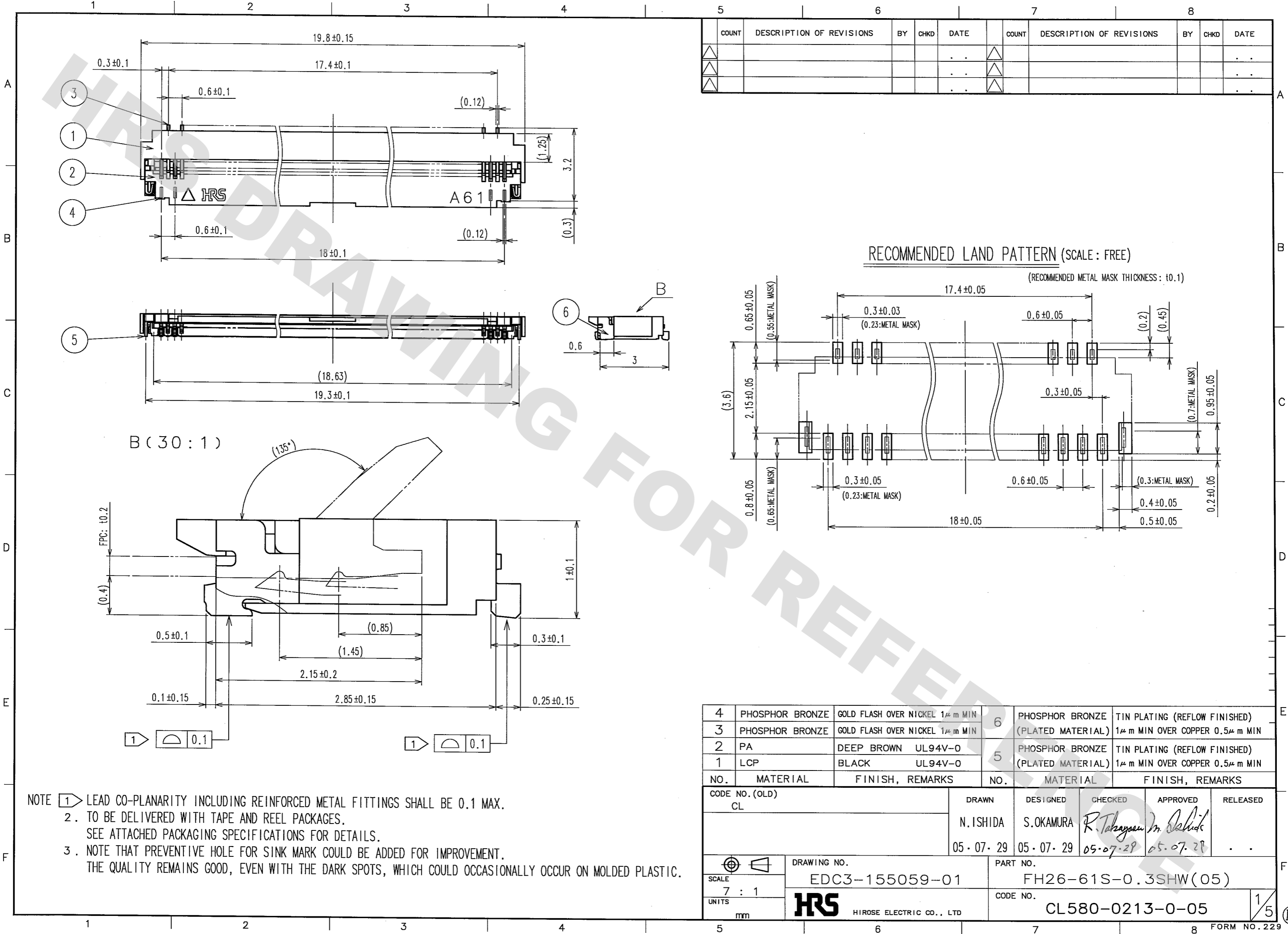

COUNT	DESCRIPTION OF REVISIONS	BY	CHKD	DATE	COUNT	DESCRIPTION OF REVISIONS	BY	CHKD	DATE

4	PHOSPHOR BRONZE	GOLD FLASH OVER NICKEL 1μm MIN	6	PHOSPHOR BRONZE	TIN PLATING (REFLOW FINISHED)
3	PHOSPHOR BRONZE	GOLD FLASH OVER NICKEL 1μm MIN		(PLATED MATERIAL)	1μm MIN OVER COPPER 0.5μm MIN
2	PA	DEEP BROWN UL94V-0	5	PHOSPHOR BRONZE	TIN PLATING (REFLOW FINISHED)
1	LCP	BLACK UL94V-0		(PLATED MATERIAL)	1μm MIN OVER COPPER 0.5μm MIN
NO.	MATERIAL	FINISH, REMARKS	NO.	MATERIAL	FINISH, REMARKS

CODE NO. (OLD) CL		DRAWN N. ISHIDA	DESIGNED S. OKAMURA	CHECKED <i>R. Takayama</i>	APPROVED <i>M. Sakai</i>	RELEASED
		05.07.29	05.07.29	05.07.29	05.07.29	
DRAWING NO. EDC3-155059-01		PART NO. FH26-61S-0.3SHW(05)		CODE NO. CL580-0213-0-05		
SCALE 7 : 1		HRS HIROSE ELECTRIC CO., LTD		1/5		
UNITS mm				FORM NO. 229		

NOTE 1) LEAD CO-PLANARITY INCLUDING REINFORCED METAL FITTINGS SHALL BE 0.1 MAX.
 2. TO BE DELIVERED WITH TAPE AND REEL PACKAGES. SEE ATTACHED PACKAGING SPECIFICATIONS FOR DETAILS.
 3. NOTE THAT PREVENTIVE HOLE FOR SINK MARK COULD BE ADDED FOR IMPROVEMENT. THE QUALITY REMAINS GOOD, EVEN WITH THE DARK SPOTS, WHICH COULD OCCASIONALLY OCCUR ON MOLDED PLASTIC.

TO
NC

COUNT	DESCRIPTION OF REVISIONS	BY	CHKD	DATE	COUNT	DESCRIPTION OF REVISIONS	BY	CHKD	DATE
△					△				
△					△				
△					△				

RECOMMENDED FPC(FREE) (SCALE: FREE)

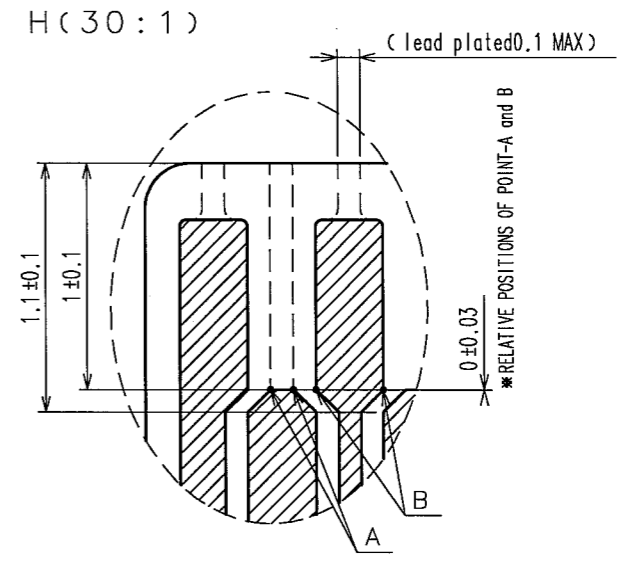
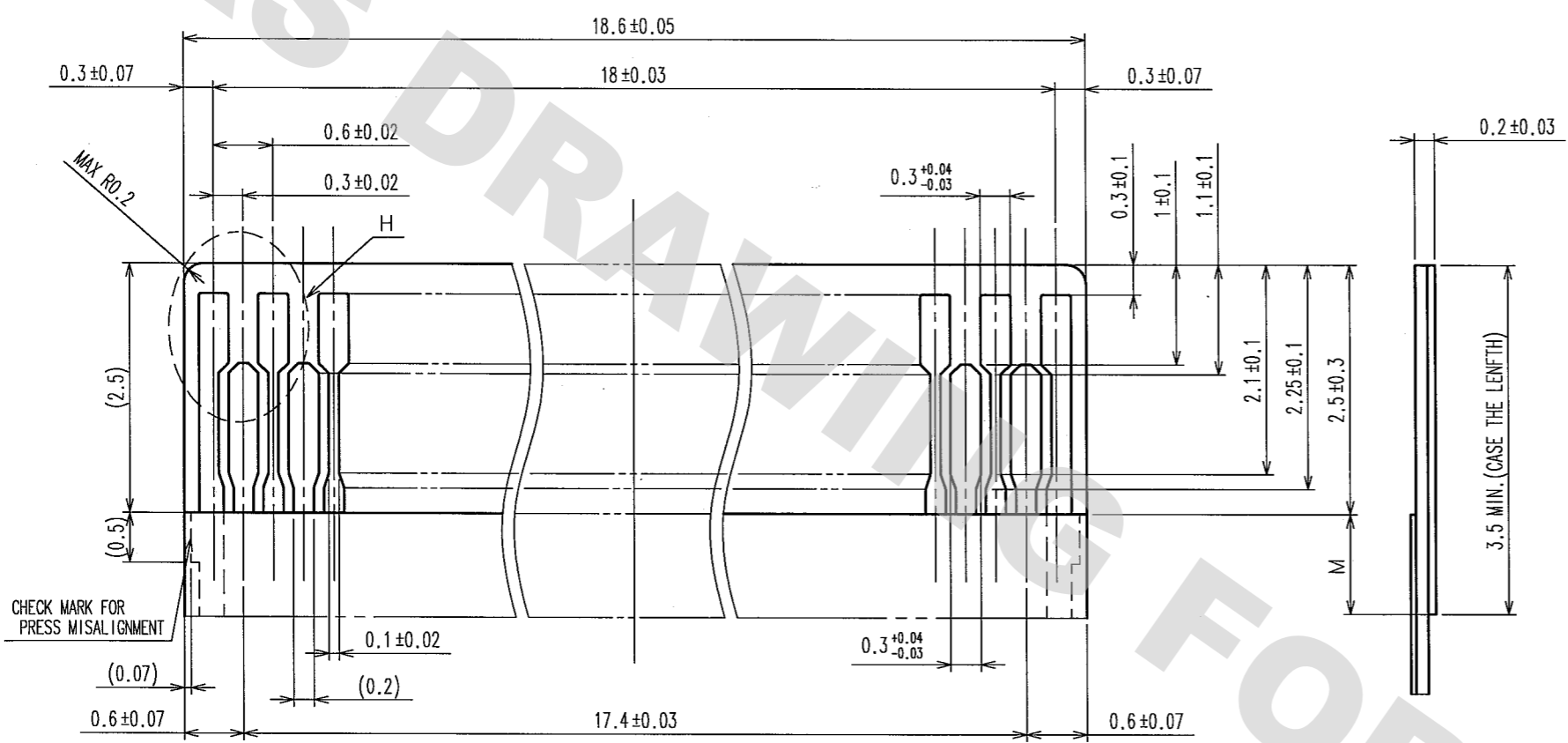

DIMENSION M SHALL BE 0.5mm MIN. IN CASE THE LENGTH OF STIFFENER IS 3.5mm MAX DUE TO FPC DESIGN.

FPC CONSTRUCTION Recommended Specifications

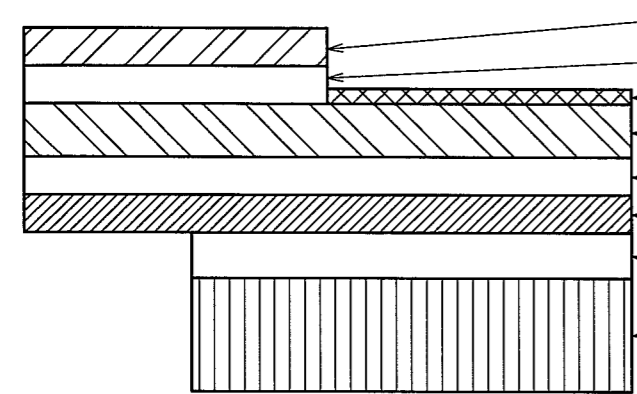

MATERIAL NAME	MATERIAL	THICKNESS(μm)
COVERING FILM LAYER.	POLYAMIDE 1mil thick.	25
COVER ADHESIVE		25
SURFACE TREATMENT	PLATING TREATMENT	5
COPPER FOIL	Cu 1 oz	35
BASE ADHESIVE	HEAT-HARDENED ADHESIVE	25
BASE FILM	POLYAMIDE 1mil thick	25
REINFORCEMENT MATERIAL ADHESIVE	HEAT-HARDENED ADHESIVE	40
STIFFENER	POLYAMIDE 3mil thick	75

NO.	MATERIAL	FINISH, REMARKS	NO.	MATERIAL	FINISH, REMARKS
CODE NO.(OLD)	CL		DRAWN	DESIGNED	CHECKED
			N.ISHIDA	S.OKAMURA	R. Takayama
			05.07.29	05.07.29	05.07.29
DRAWING NO. EDC3-155059-01			PART NO. FH26-61S-0.3SHW(05)		
SCALE - : 1			CODE NO. CL580-0213-0-05		
UNITS mm			HRS HIROSE ELECTRIC CO., LTD		

DRAWING FOR REFERENCE: This is subject to change without notice
08/11/2012

TO
NC

COUNT	DESCRIPTION OF REVISIONS	BY	CHKD	DATE	COUNT	DESCRIPTION OF REVISIONS	BY	CHKD	DATE

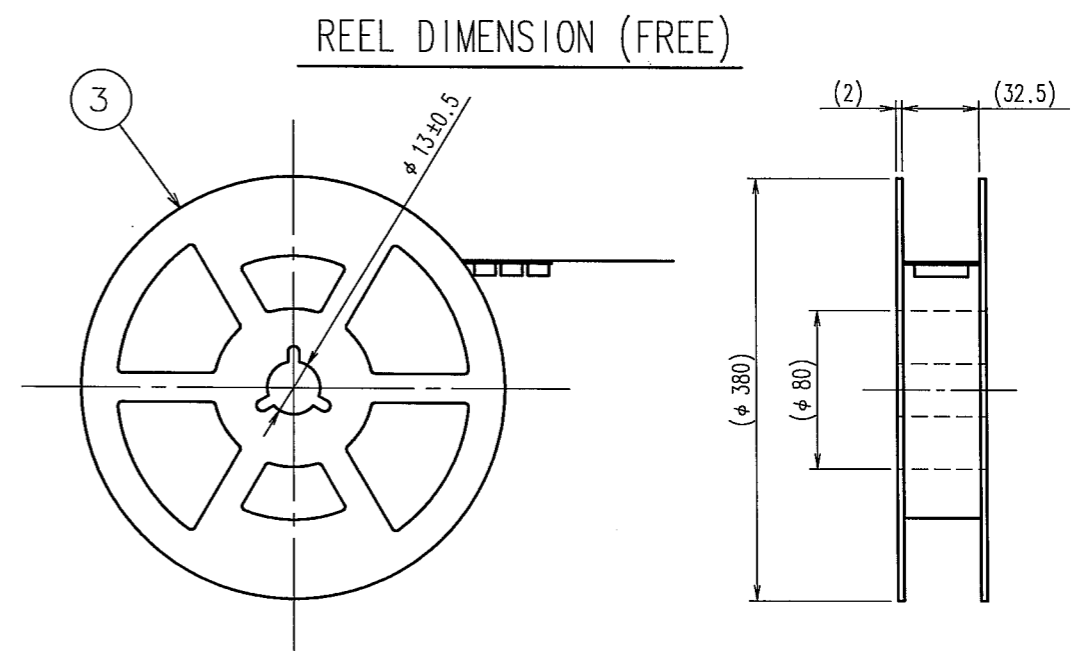
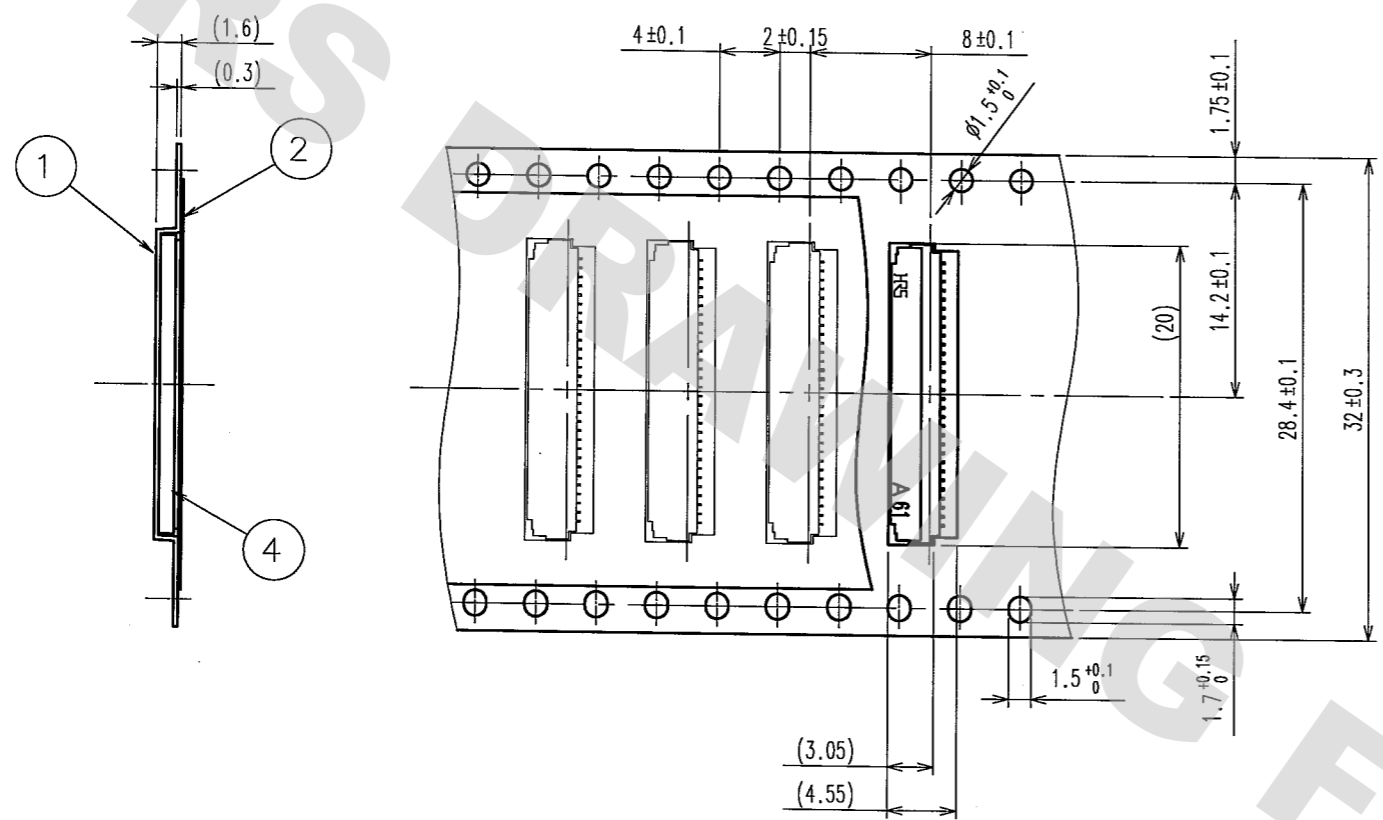

→
DIRECTION OF UNREELING

NOTE 1 THE DIMENSIONS IN PARENTHESES ARE FOR REFERENCE.
 2 PER REEL : 5000 CONNECTORS.
 3 REFER TO JIS C 0806 (PACKAGING OF COMPONENTS FOR AUTOMATIC HANDLING.)

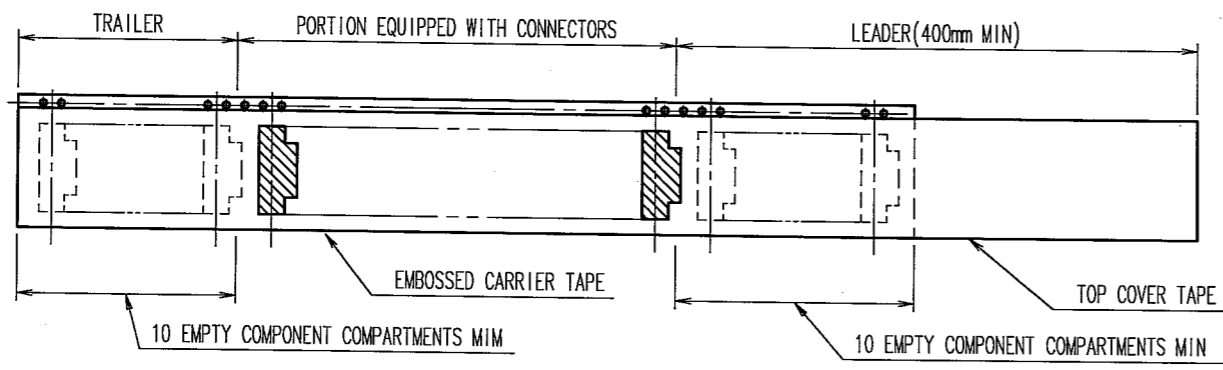

2	POLYESTER		4	(CONNECTOR)	
1	POLYSTYRENE		3	POLYSTYRENE	
NO.	MATERIAL	FINISH, REMARKS	NO.	MATERIAL	FINISH, REMARKS
CODE NO. (OLD) CL		DRAWN N. ISHIDA 05.07.29	DESIGNED S. OKAMURA 05.07.29	CHECKED R. Takayama 05.07.29	APPROVED M. Akishima 05.07.29
DRAWING NO. EDC3-155059-01			PART NO. FH26-61S-0.3SHW(05)		
SCALE 2:1			CODE NO. CL580-0213-0-05		
UNITS mm			3		

DRAWING FOR REFERENCE: This is subject to change without notice
08/11/2012

TO
NC

This connector is small and thin and requires delicate and careful handling.
 Read through the instructions shown below and handle the connector properly.
 Each values indicating here are for reference and may differ from standard value.

【 INSTRUCTIONS FOR MOUNTING ON THE BOARD 】

- ◆ **Warp of Board**
 Minimize warp of the board as much as possible.
 Lead co-planarity including reinforced metal fittings is 0.1 mm or less.
 Too much warp of the board may result in a soldering failure.
- ◆ **Load to Connector**
 Do not apply a force of 0.5 N or more to the connector before mounting it on the board.
 Otherwise, the connector may be broken.
 Do not insert the FPC or operate the connector before mounting it.
- ◆ **Load to Board**
 - Splitting a large board into several pieces
 - Screwing the board
 Avoid the handling described above so that no force is exerted on the board during the assembly process.
 Otherwise, the connector may become defective.
- ◆ **Amount of Warp**
 The warp of a 100-mm wide board should be 0.5 mm or less.
 The warp of board suffers stress on connector and the connector may become defective.

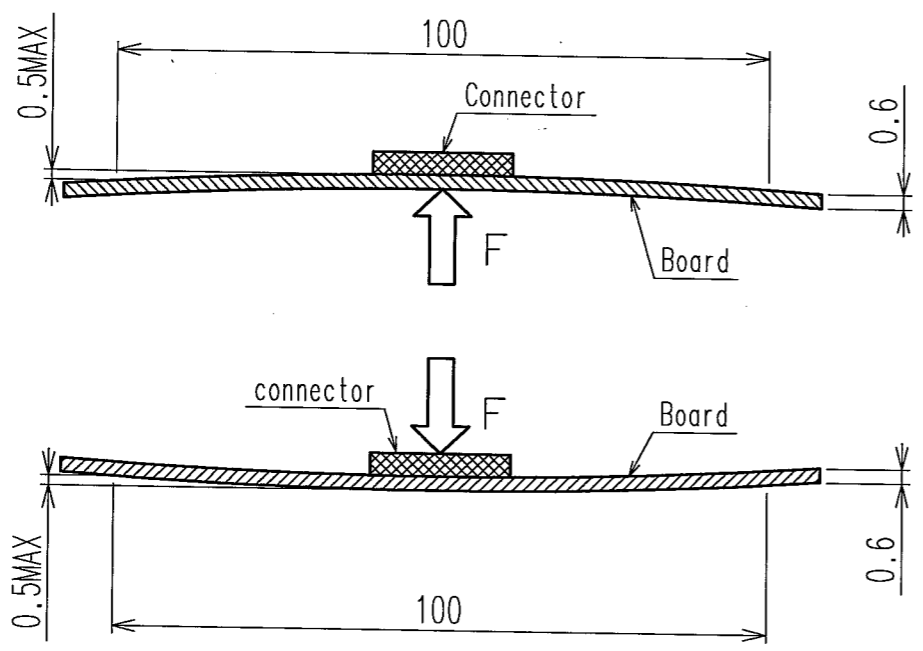

COUNT	DESCRIPTION OF REVISIONS	BY	CHKD	DATE	COUNT	DESCRIPTION OF REVISIONS	BY	CHKD	DATE
△					△				
△					△				
△					△				

【 INSTRUCTIONS ON INSERTING FPC AND CONNECTION 】

- ◆ **Use of the Lock Lever**
 1. Be very careful not to apply excessive force when releasing the lock lever in the initial position (with no FPC inserted).
 If you use your nail or finger as shown below, the terminals may be deformed.

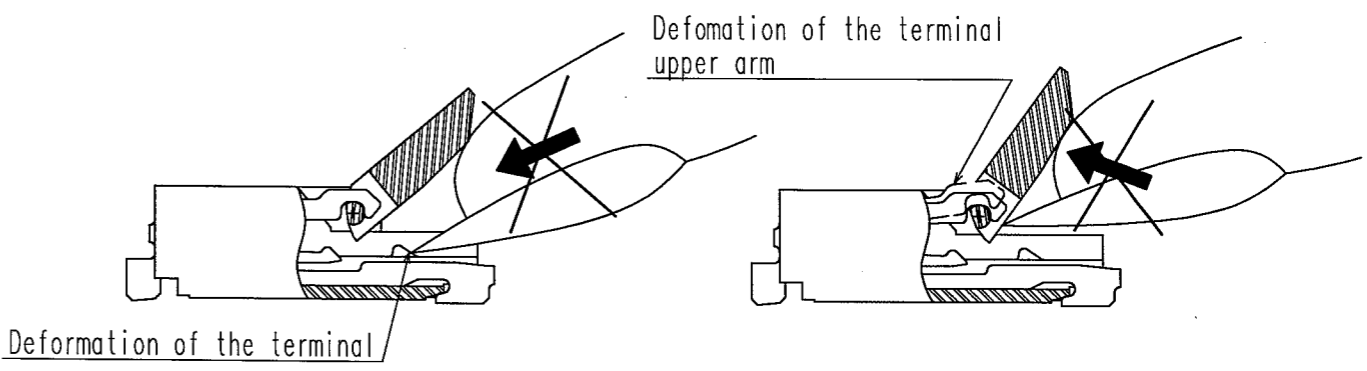

Example 1

Example 2

2. The lock lever rotates around the rotational axis as shown below.
 Rotate the lock lever.

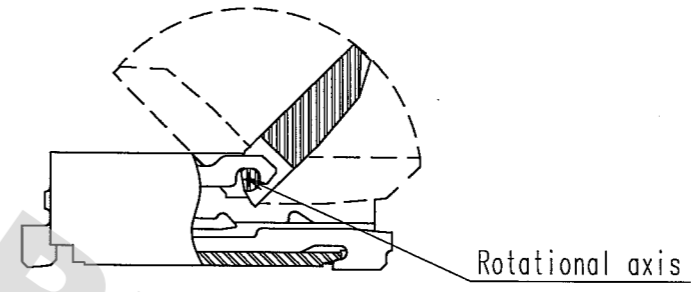

3. The lock lever will not open more than 135°.
 Do not apply any force backward beyond this point.
 Otherwise, the lock lever may come off or break.

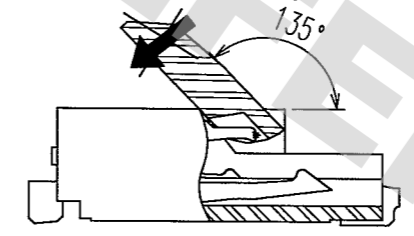

DRAWING FOR REFERENCE: This is subject to change without notice
08/11/2012

TO
NC

CODE NO. (OLD) CL	DRAWN N. ISHIDA 05-07-29	DESIGNED S. OKAMURA 05-07-29	CHECKED R. Takayanagi 05-07-29	APPROVED M. Ishida 05-07-29	RELEASED .
INSTRUCTION MANUAL		DRAWING NO. EDC3-155059-01		PART NO. FH26-61S-0.3SHW(05)	
SCALE - : 1	UNITS mm	HRS HIROSE ELECTRIC CO., LTD		CODE NO. CL580-0213-0-05	4

DRAWING FOR REFERENCE: This is subject to change without notice
08/11/2012

TO
NC

4. Move the lock lever at approximately the center.
5. Do not pinch or pick the lock lever to lift it as shown below. Otherwise, it may break.
(Do not carry out any operation other than rotating the lever as shown in 2 above.)

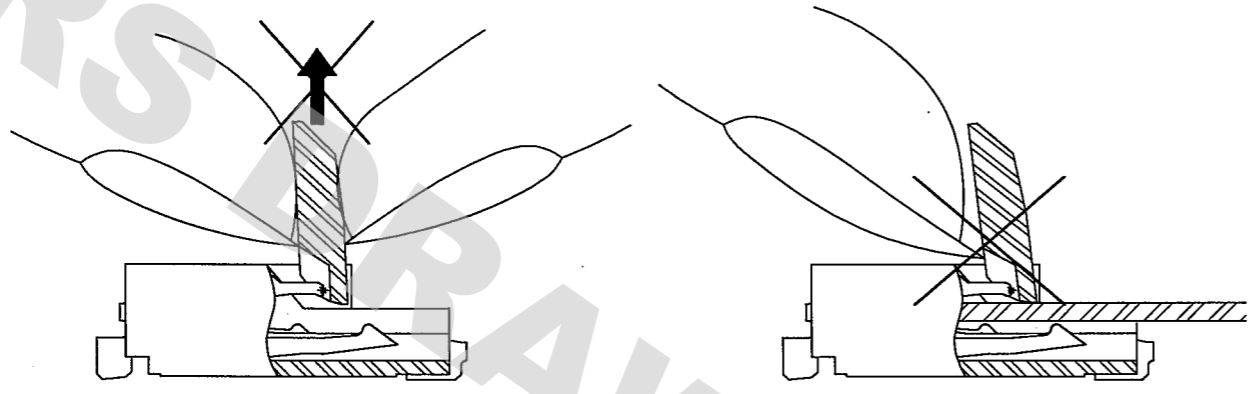

◆ Direction of Contacts
This connector has contacts on the bottom. Thus, insert it with the exposed conductors face down.

◆ Inserting the FPC
1. Insert the FPC horizontally along the surface and at a right angle to the connector. Insert it properly to the very end. If the FPC is inserted at a slant (incorrectly), the conductors may short-circuit due to pitch shift or the edge of the FPC may catch in the terminals, resulting in deformation of the terminals. This connector has a ZIF structure, and its effective engagement length is 0.35 mm (when the recommended FPC nominal is used). Use the lock lever carefully to prevent the FPC from dislocating after inserting it.

2. Do not insert the FPC diagonally from above. If the FPC is inserted at a slant (incorrectly) as shown below in the FPC insertion process, the FPC may bend and patterns may break or the FPC may not insert completely, resulting in improper conduction.

- *Keep a sufficient FPC insertion space in the stage of the layout in order to avoid incorrect FPC insertion. Besides, it is not difficult to insert FPC correctly all the way to the end. Design the proper layout of parts.
- *Make adjustments with the FPC manufacturer for FPC bending performance and wire breakage.

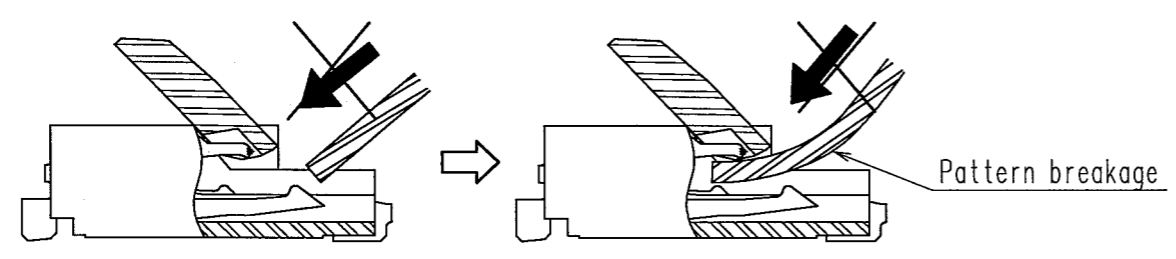

◆ Checking the Locking Condition
In the locked condition, make sure that the lock lever is horizontal on the board surface. Do not apply excessive force to it near the 0° position of the lever. Otherwise, the terminals may be deformed. (Allowable force: 1 N or less)

5				6				7				8			
COUNT	DESCRIPTION OF REVISIONS	BY	CHKD	DATE	COUNT	DESCRIPTION OF REVISIONS	BY	CHKD	DATE	COUNT	DESCRIPTION OF REVISIONS	BY	CHKD	DATE	
△					△					△					
△					△					△					
△					△					△					

【 INSTRUCTIONS ON FPC LAYOUT AFTER CONNECTION 】

◆ Load to FPC
Be very careful not to apply any force to the FPC after inserting it. Otherwise, the connector may become unlocked or the FPC may break. Fix the FPC, in particular, when loads are applied to it continuously. Design the FPC layout with care not to bend it sharply near the insertion opening.

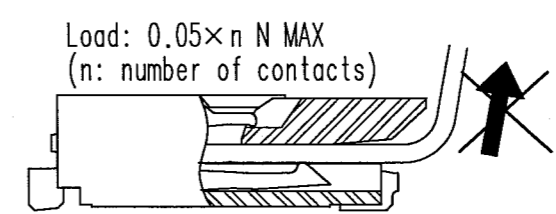

【 INSTRUCTIONS ON REMOVING FPC 】

◆ Release the lock lever to remove the FPC.

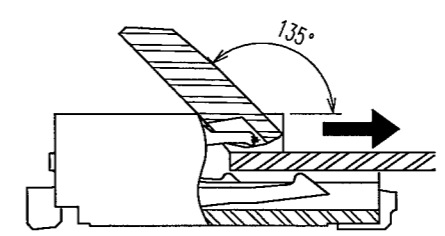

【 OTHER INSTRUCTIONS 】

◆ Instructions on Manual Soldering
Follow the instructions shown below when soldering the connector manually during repair work, etc.
1. Do not perform reflow soldering or manual soldering with the FPC inserted into the connector.
2. Do not heat the connector excessively. Be very careful not to let the soldering iron contact any parts other than connector leads. Otherwise, the connector may be deformed or melt.
3. Do not use excessive solder (or flux).
If excessive solder (or flux) is used on the terminals, solder or flux may adhere to the contacts or rotating parts of the lock lever, resulting in poor contact or a rotation failure of the lock lever.
Supplying excessive solder to the reinforcing bracket may hinder lock lever rotation, resulting in breakage of the connector.

CODE NO. (OLD) CL	DRAWN N. ISHIDA 05-07-29	DESIGNED S. OKAMURA 05-07-29	CHECKED <i>R. Takayama</i> 05-07-29	APPROVED <i>M. Ishida</i> 05-07-29	RELEASED .
INSTRUCTION MANUAL					
SCALE - : 1	DRAWING NO. EDC3-155059-01		PART NO. FH26-61S-0.3SHW(05)		
UNITS mm	HRS HIROSE ELECTRIC CO., LTD		CODE NO. CL580-0213-0-05		5

X-ON Electronics

Largest Supplier of Electrical and Electronic Components

Click to view similar products for [FFC & FPC Connectors](#) category:

Click to view products by [Hirose](#) manufacturer:

Other Similar products are found below :

[K-FC20](#) [FH29B-80S-0.2SHW\(99\)](#) [FPH-2022G](#) [AYF332735](#) [52610-1075](#) [52610-1275](#) [52610-1934](#) [501864-3091-TR225](#) [086222026001800](#)
[52610-0675](#) [62684-36210E9ALF](#) [52746-1671-TR250](#) [10051922-2810EHLF](#) [6-520415-9](#) [SFV6R-1STE9HLF](#) [XF3M-2915-1B-R100](#)
[1658549-1](#) [46214008010800](#) [AYF534065TA](#) [AYF351525](#) [086212040340800+](#) [AYF530365TA](#) [67000-014LF](#) [67000-004LF](#)
[006207341915000+](#) [DS1020-19RT1D](#) [67000-003LF](#) [67000-011LF](#) [67000-016LF](#) [HFW14R-2STE9LF](#) [SFV32R-2STBE9HLF](#) [SFW12R-](#)
[5STE9LF](#) [SFW18R-1STAE9LF](#) [SFW4R-5STE9LF](#) [52807-0430](#) [046283021002868+](#) [THD1015-8CL-SN](#) [67000-006LF](#) [502250-8027](#)
[104267-9617](#) [66987-011LF](#) [AYF362535](#) [F0501-T-50-20T-R](#) [HFW8S-2STAE1HLF](#) [67000-008LF](#) [67000-012LF](#) [ECC576069EU](#) [F1002-B-](#)
[20-20T-R](#) [HFW15S-2STAE1HLF](#) [0781271110](#)