

Feb.1.2022 Copyright 2022 HIROSE ELECTRIC CO., LTD. All Rights Reserved.
In case of consideration for using Automotive equipment / device which demand high reliability, kindly contact our sales window correspondents.

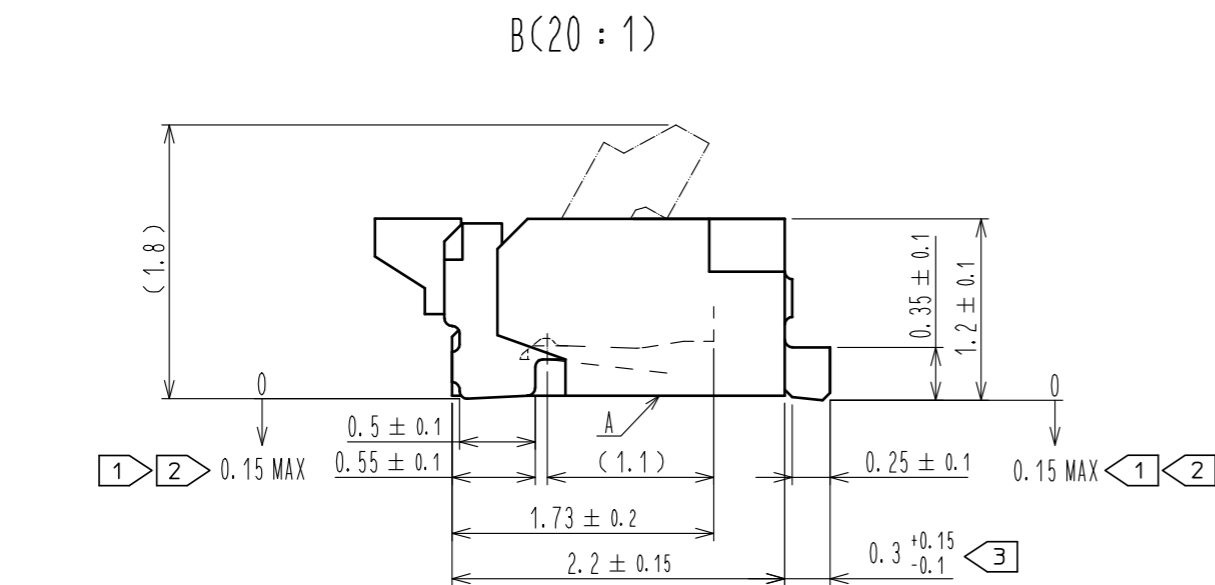
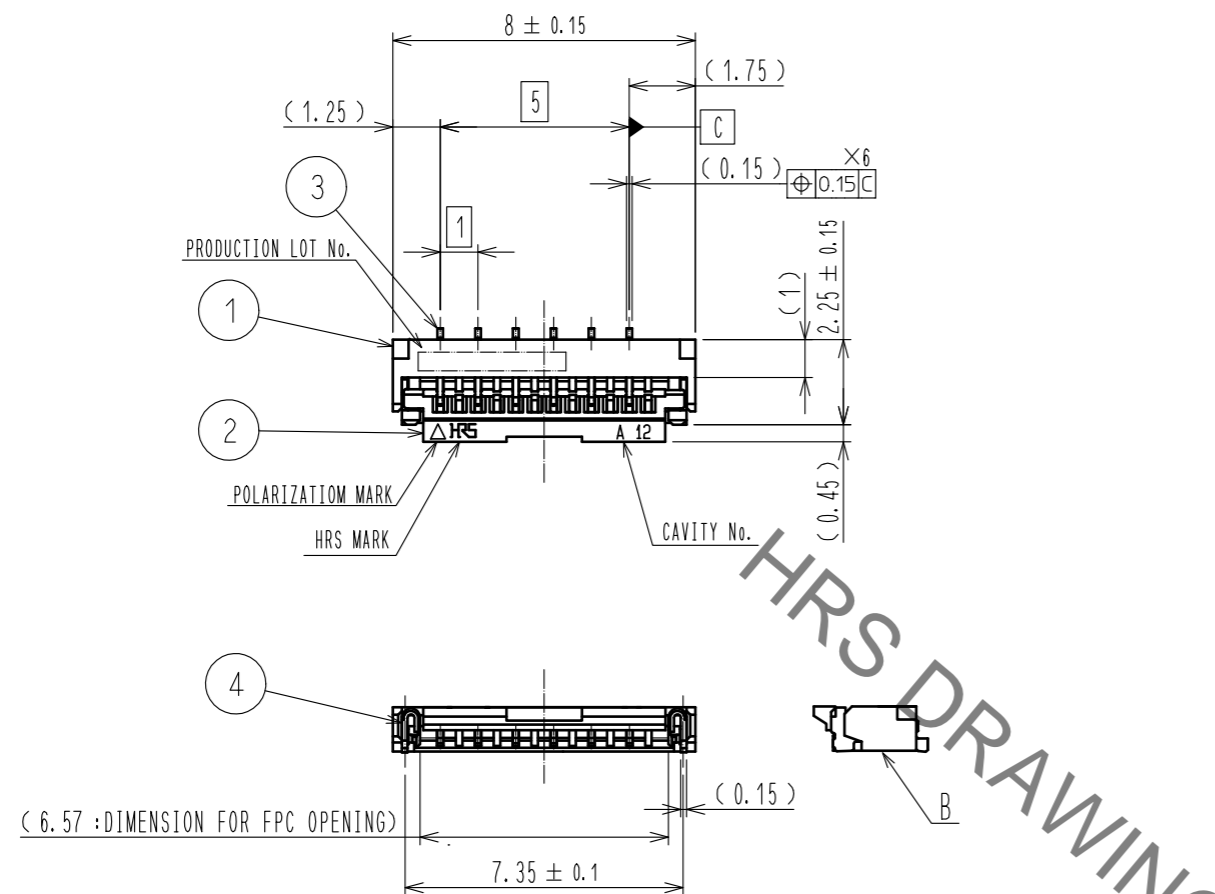

- NOTES
- ① LEAD CO-PLANARITY INCLUDING REINFORCED METAL FITTINGS SHALL BE 0.1 MAX.
 - ② DIMENSION: FROM REFERENCE A.
 - ③ DIFFERENCE OF EACH CONTACT LEAD TO BE MAX 0.1.
 - 4 TO BE DELIVERED WITH TAPE AND REEL PACKAGES. SEE ATTACHED PACKAGING SPECIFICATIONS FOR DETAILS.
 - 5 NOTE THAT PREVENTIVE HOLE FOR SINK MARK COULD BE ADDED FOR IMPROVEMENT.
 - 6 THE DIMENSIONS IN PARENTHESES ARE FOR REFERENCE.

RECOMMENDED LAND PATTERN, METAL MASK(FREE)

RECOMMENDED METAL MASK THICKNESS: t=0.10

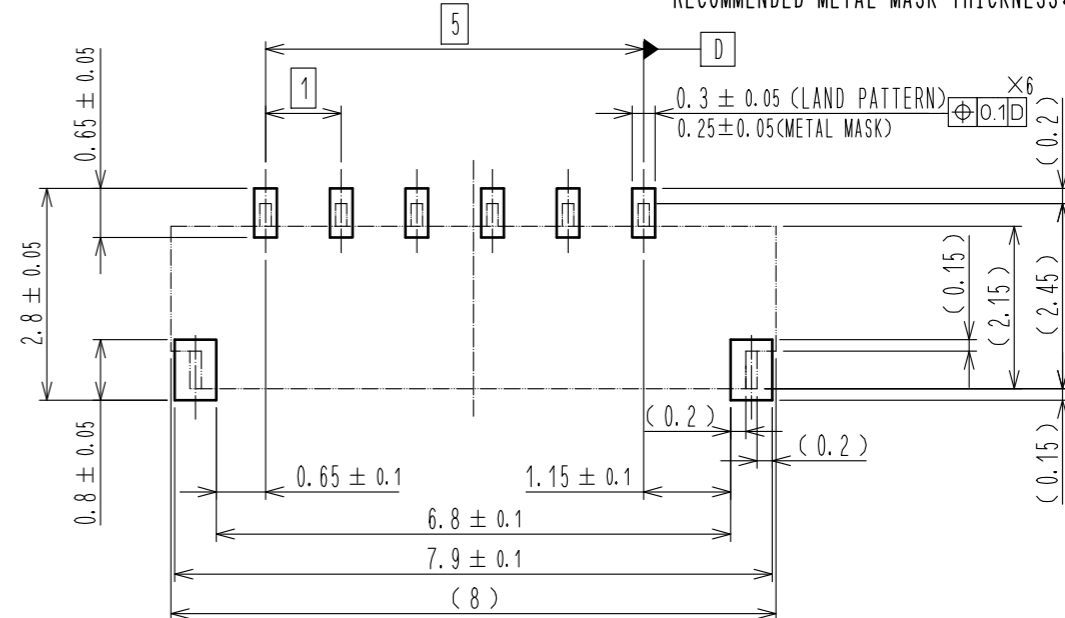

RECOMMENDED FPC, FFC(FREE)

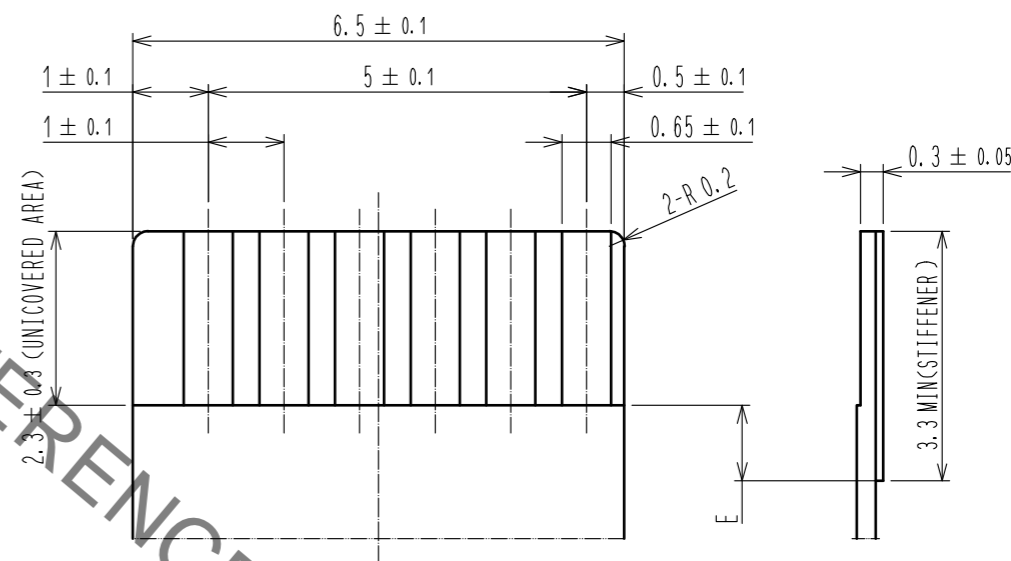

FOR FPC APPLICATION, STIFFENER MATERIAL IS POLYIMID, HEAT CURED ADHESIVE.
FOR FFC APPLICATION, PAY ATTENTION TO THE TOLERANCE OF FPC THICKNESS AT MATING AREA.
DIMENSION E MUST BE 0.5mm MINIMUM WHEN THE STIFFENER IS SHORTER THAN 3.3mm.

4	PHODPHOR BRONZE (PLATED MATERIAL)	TIN PLATING(REFLOW FINISHED) 1μm MIN OVER COPPER 0.5μm MIN			
3	PHODPHOR BRONZE	(CONTACT AREA, LEAD) GOLD PLATING 0.05μm MIN OVER NICKEL 1μm MIN (OTHER) NICKEL PLATING 1μm MIN	8	(CONNECTOR)	
2	PA	DEEP BROWN UL94V-0	7	POLYSTYRENE	
1	PA	BEIGE UL94V-0	6	POLYESTER	
			5	POLYSTYRENE	
NO.	MATERIAL	FINISH . REMARKS	NO.	MATERIAL	FINISH . REMARKS
UNITS mm		SCALE 5 : 1	COUNT	DESCRIPTION OF REVISIONS	
DESIGNED		CHECKED		DATE	
APPROVED : HS. HIRAHARA		20211229		DRAWING NO. EDC-159289-99-00	
CHECKED : HS. HIRAHARA		20211229		PART NO. FH33-12(6)SB-1SH(99)	
DESIGNED : NM. YONEYAMA		20211223		CODE NO. CL0580-1323-4-99	
DRAWN : TS. HONJO		20211223			

Feb.1.2022 Copyright 2022 HIROSE ELECTRIC CO., LTD. All Rights Reserved.
 In case of consideration for using Automotive equipment / device which demand high reliability, kindly contact our sales window correspondents.

EMBOSSED CARRIER TAPE DIMENSIONS(2:1)

REEL DIMENSIONS (FREE)

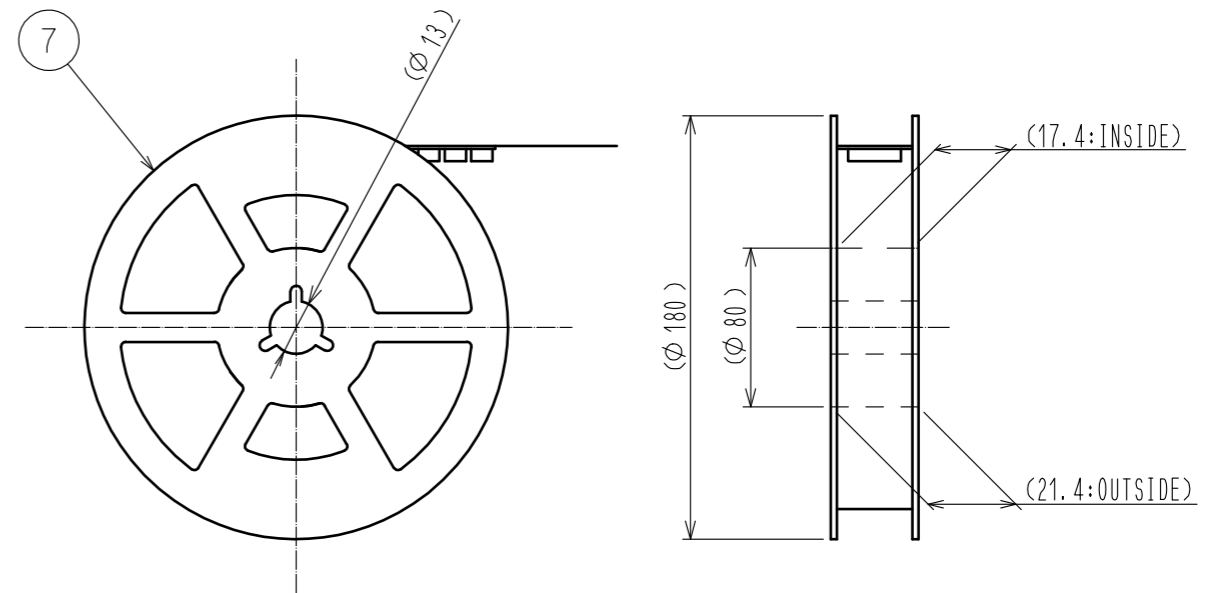
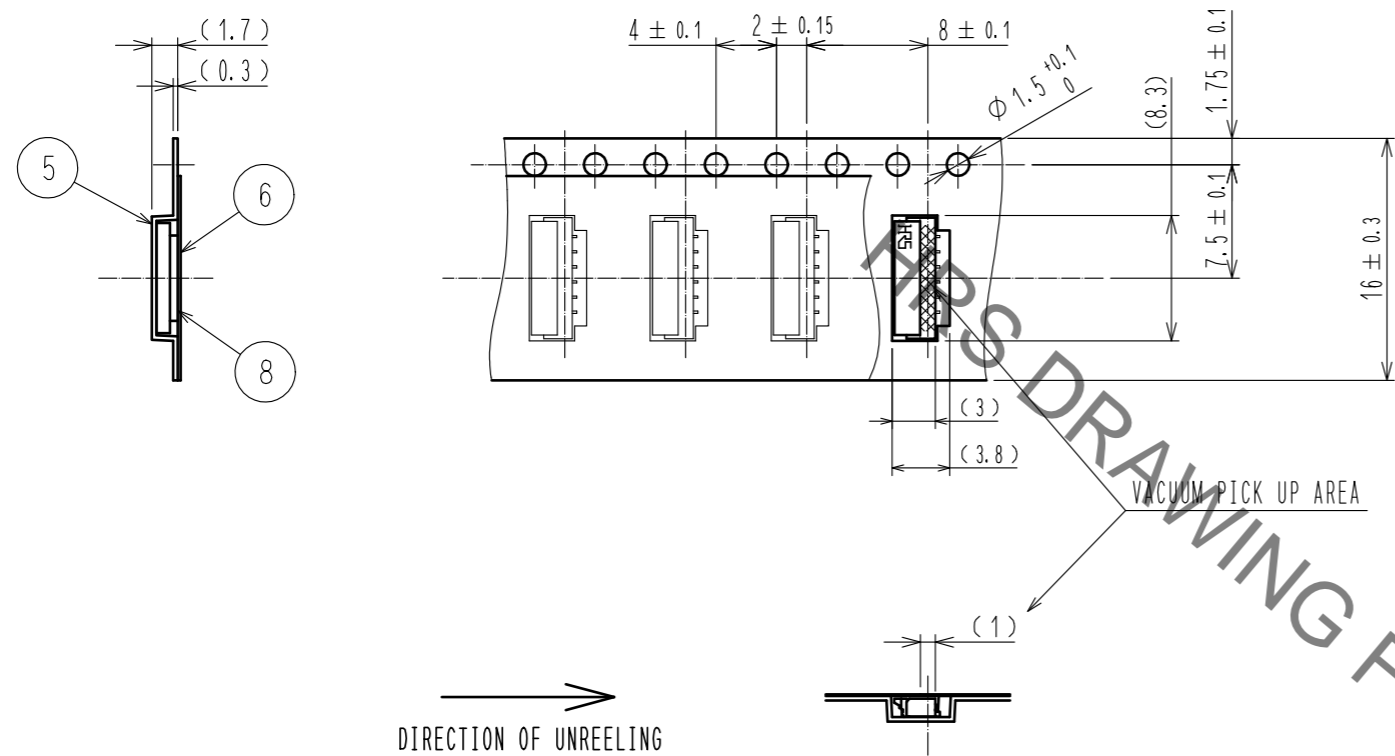

NOTES 7 PER REEL:500 CONNECTORS.
 8 REFER TO JIS C 0806 AND IEC 60286-3(PACKAGING OF COMPONENTS FOR AUTOMATIC HANDLING.)

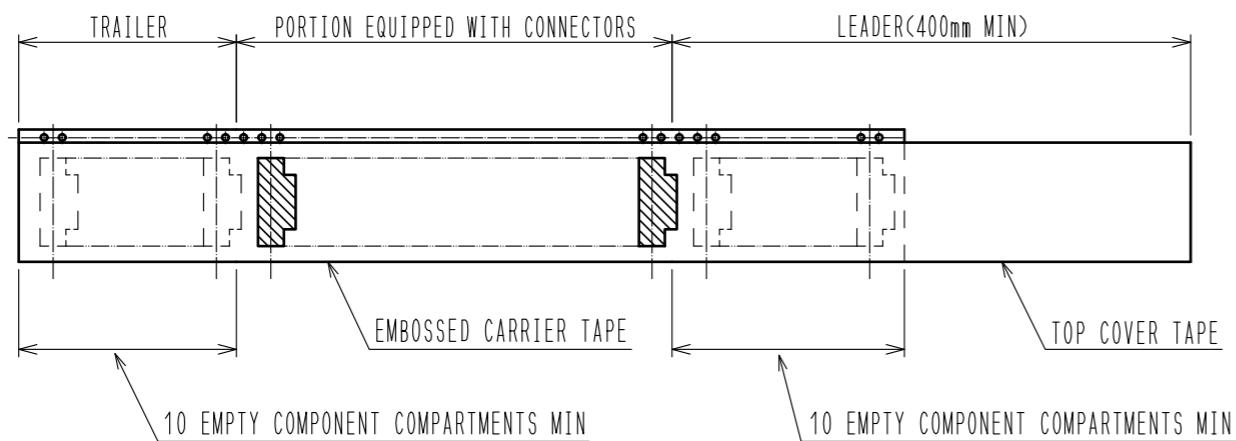

< DRAWING FOR PACKING >

HRS	DRAWING NO.	EDC-159289-99-00
	PART NO.	FH33-12(6)SB-1SH(99)
	CODE NO.	CL0580-1323-4-99
		2/4

Feb.1.2022 Copyright 2022 HIROSE ELECTRIC CO., LTD. All Rights Reserved.
In case of consideration for using Automotive equipment / device which demand high reliability, kindly contact our sales window correspondents.

This connector is small and thin and requires delicate and careful handling.
Read through the instructions shown below and handle the connector properly.
Each values indicating here are for reference and may differ from standard value.

[INSTRUCTIONS FOR MOUNTING ON THE BOARD]

◆Warp of Board

Minimize warp of the board as much as possible.
Lead co-planarity including reinforced metal fittings is 0.1 mm or less.
Too much warp of the board may result in a soldering failure.

◆Load to Connector

Do not apply a force of 1 N or more to the connector before mounting it on the board.
Otherwise, the connector may be broken.
Do not insert the FPC or operate the connector before mounting it.

◆Load to Board

• Splitting a large board into several pieces
• Screwing the board
Avoid the handling described above so that no force is exerted on the board during the assembly process.
Otherwise, the connector may become defective.

◆Amount of Warp

The warp of a 100mm wide board should be 1mm or less.
The warp of board suffers stress on connector and the connector may become defective.

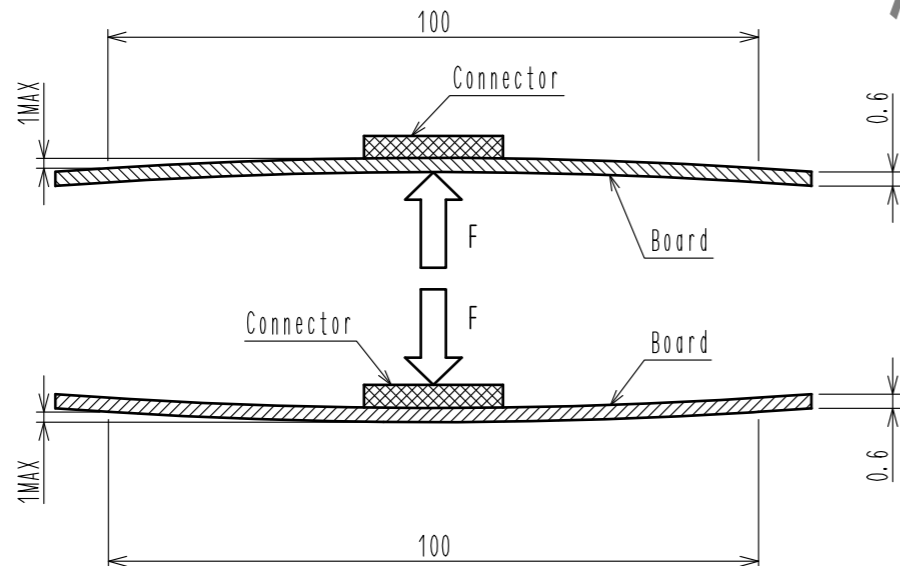

[INSTRUCTIONS ON INSERTING FPC AND CONNECTION]

◆Use of the Actuator

1. Be very careful not to apply excessive force when releasing the actuator in the initial position (with no FPC inserted).
If you use your nail or finger as shown below, the terminals may be deformed.

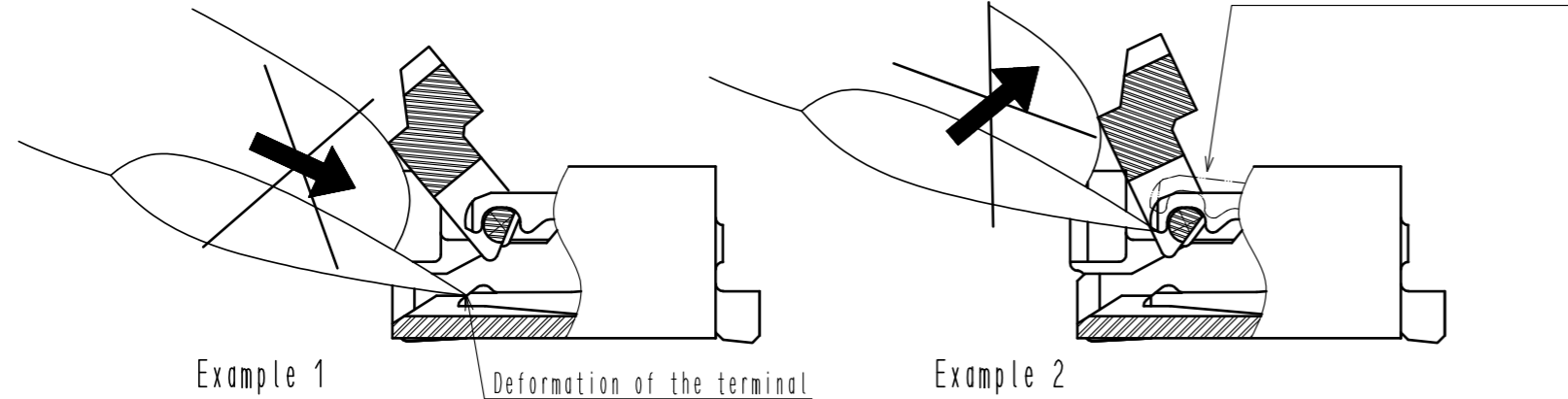

2. the actuator rotates around the rotational axis as shown below.
Rotate the actuator.

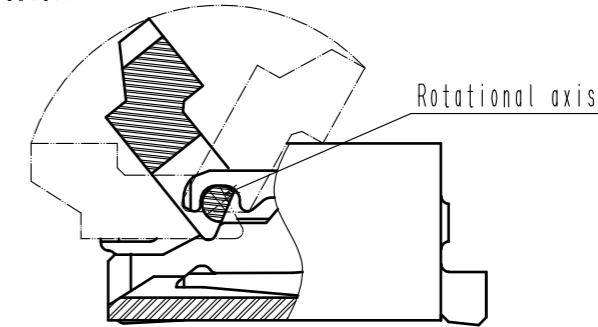

3. the actuator will not open more than 120°. Do not apply any force backward beyond this point. Otherwise, the actuator may come off or break.

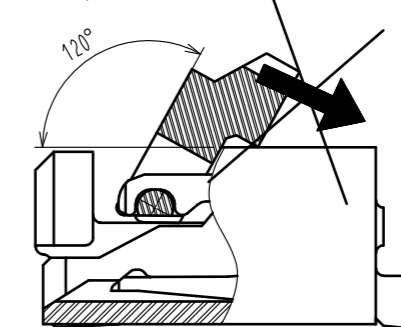

4. Move the actuator at approximately the Center. Do not operate the edge of actuator. Otherwise, the actuator may come off or break.

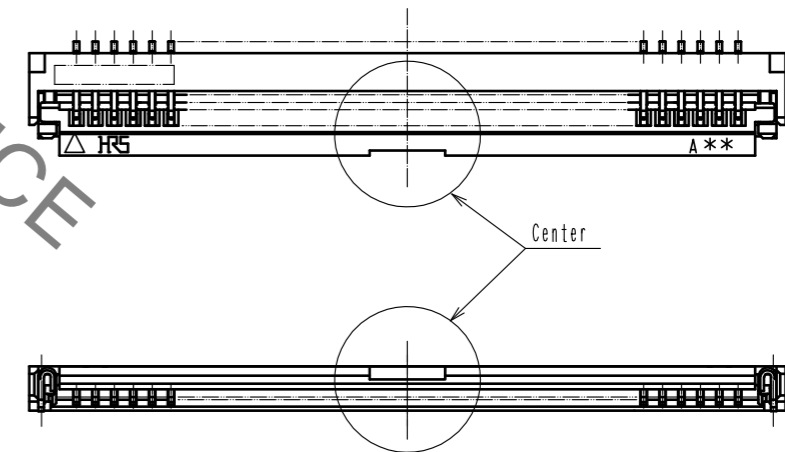

< INSTRUCTION MANUAL 1 >

HRS	DRAWING NO.	EDC-159289-99-00
	PART NO.	FH33-12(6)SB-1SH(99)
	CODE NO.	CL0580-1323-4-99
		3/4

Feb.1.2022 Copyright 2022 HIROSE ELECTRIC CO., LTD. All Rights Reserved.
In case of consideration for using Automotive equipment / device which demand high reliability, kindly contact our sales window correspondents.

5. Do not pinch or pick the actuator to lift it as shown below.
Otherwise, it may break.
(Do not carry out any operation other than rotating the actuator as shown in 2 above.)

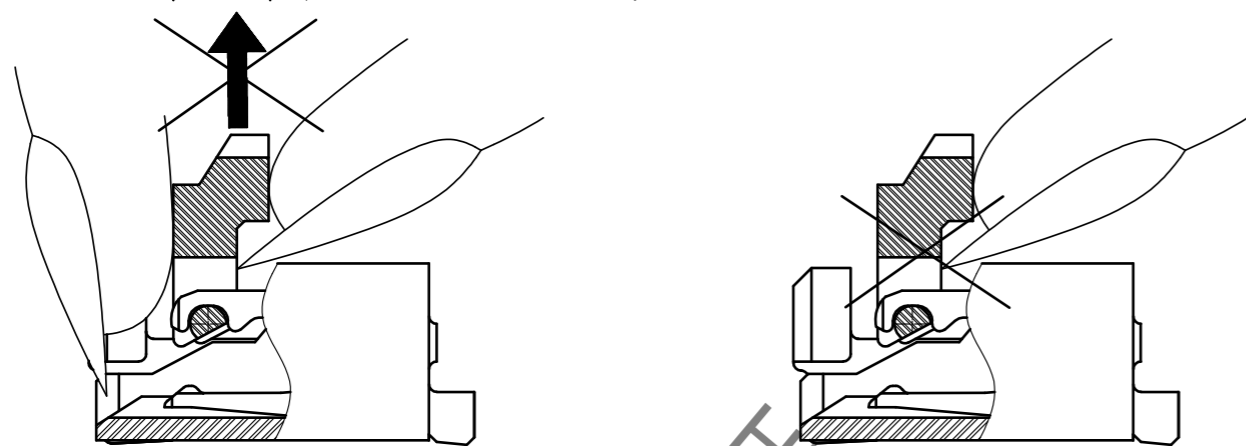

◆Direction of Contacts

This connector has contacts on the bottom. Thus, insert it with the exposed conductors face down.

◆Inserting the FPC

1. Insert the FPC horizontally along the surface and at a right angle to the connector.
Insert it properly to the very end.
IF the FPC is inserted at a slant (incorrectly),
the conductors may short-circuit due to pitch shift or the edge of the FPC may catch in the terminals,
resulting in deformation of the terminals.
This connector has a ZIF structure, and its effective engagement length is 1.1 mm
(when the recommended FPC nominal is used).
Use the actuator carefully to prevent the FPC from dislocating after inserting it.

2. Do not insert the FPC diagonally from above.
IF the FPC is inserted at a slant (incorrectly) as shown below in the FPC insertion process,
the FPC may bend and patterns may break or the FPC may not insert completely,
resulting in improper conduction.

※Keep a sufficient FPC insertion space in the stage of the layout in order to avoid incorrect FPC insertion.
Besides, it is not difficult to insert FPC correctly all the way to the end.
Design the proper layout of parts.

※Make adjustments with the FPC manufacturer for FPC bending performance and wire breakage.

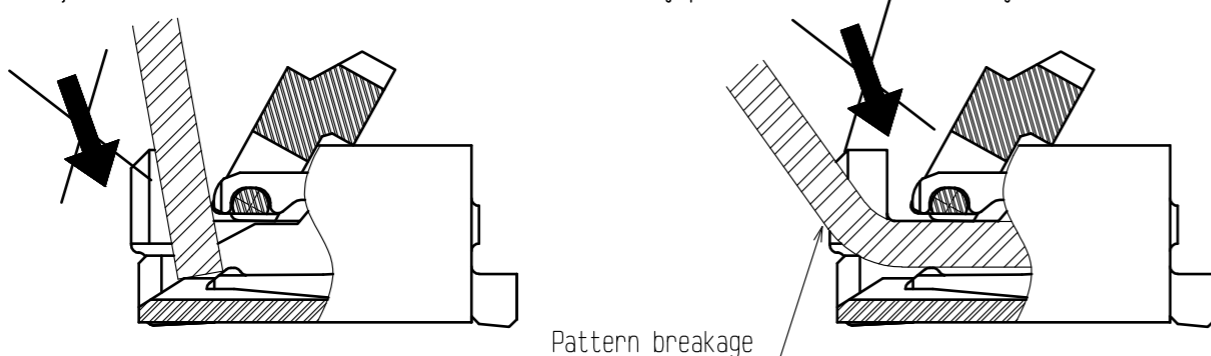

◆Checking the Locking Condition

In the locked condition, make sure that the actuator is horizontal on the board surface.
Do not apply excessive force to it near the 0° position of the actuator.
Otherwise, the terminals may be deformed. (Allowable force: 1 N or less)

【 INSTRUCTIONS ON FPC LAYOUT AFTER CONNECTION 】

◆Load to FPC

Be very careful not to apply any force to the FPC after inserting it.
Otherwise, the connector may become unlocked or the FPC may break.
Fix the FPC, in particular, when loads are applied to it continuously.
Design the FPC layout with care not to bend it sharply near the insertion opening.

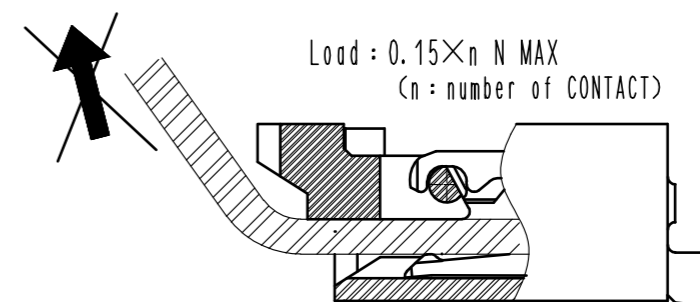

【 INSTRUCTIONS ON REMOVING FPC 】

◆Release the actuator to remove the FPC.

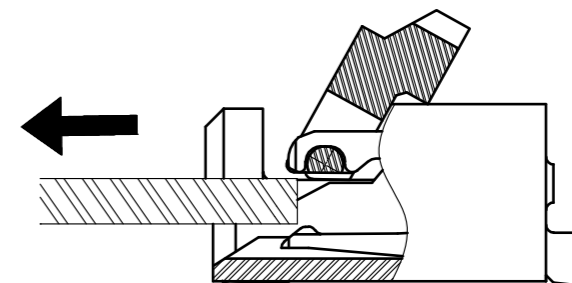

【 OTHER INSTRUCTIONS 】

◆Instructions on Manual Soldering

Follow the instructions shown below when soldering the connector manually during repair work, etc.

1. Do not perform reflow soldering or manual soldering with the FPC inserted into the connector.
2. Do not heat the connector excessively. Be very careful not to let the soldering iron contact any parts other than connector leads. Otherwise, the connector may be deformed or melt.
3. Do not use excessive solder (or flux).

If excessive solder (or flux) is used on the terminals, solder or flux may adhere to the contacts or rotating parts of the actuator, resulting in poor contact or a rotation failure of the actuator. Supplying excessive solder to the reinforcing bracket may hinder actuator rotation, resulting in breakage of the connector.

< INSTRUCTION MANUAL 2 >

HRS	DRAWING NO.	EDC-159289-99-00
	PART NO.	FH33-12(6)SB-1SH(99)
	CODE NO.	CL0580-1323-4-99

4/4

X-ON Electronics

Largest Supplier of Electrical and Electronic Components

Click to view similar products for [FFC & FPC Connectors](#) category:

Click to view products by [Hirose](#) manufacturer:

Other Similar products are found below :

[K-FC20](#) [FH29B-80S-0.2SHW\(99\)](#) [FPH-2022G](#) [AYF332735](#) [52610-1075](#) [52610-1275](#) [52610-1934](#) [501864-3091-TR225](#) [086222026001800](#)
[52610-0675](#) [62684-36210E9ALF](#) [52746-1671-TR250](#) [10051922-2810EHLF](#) [6-520415-9](#) [SFV6R-1STE9HLF](#) [XF3M-2915-1B-R100](#)
[1658549-1](#) [46214008010800](#) [AYF534065TA](#) [AYF351525](#) [086212040340800+](#) [AYF530365TA](#) [67000-014LF](#) [67000-004LF](#)
[006207341915000+](#) [DS1020-19RT1D](#) [67000-003LF](#) [67000-011LF](#) [67000-016LF](#) [HFW14R-2STE9LF](#) [SFV32R-2STBE9HLF](#) [SFW12R-](#)
[5STE9LF](#) [SFW18R-1STAE9LF](#) [SFW4R-5STE9LF](#) [52807-0430](#) [046283021002868+](#) [THD1015-8CL-SN](#) [67000-006LF](#) [502250-8027](#)
[104267-9617](#) [66987-011LF](#) [AYF362535](#) [F0501-T-50-20T-R](#) [HFW8S-2STAE1HLF](#) [67000-008LF](#) [67000-012LF](#) [ECC576069EU](#) [F1002-B-](#)
[20-20T-R](#) [HFW15S-2STAE1HLF](#) [0781271110](#)