

Dec.1.2021 Copyright 2021 HIROSE ELECTRIC CO., LTD. All Rights Reserved.
In case of consideration for using Automotive equipment / device which demand high reliability, kindly contact our sales window correspondents.

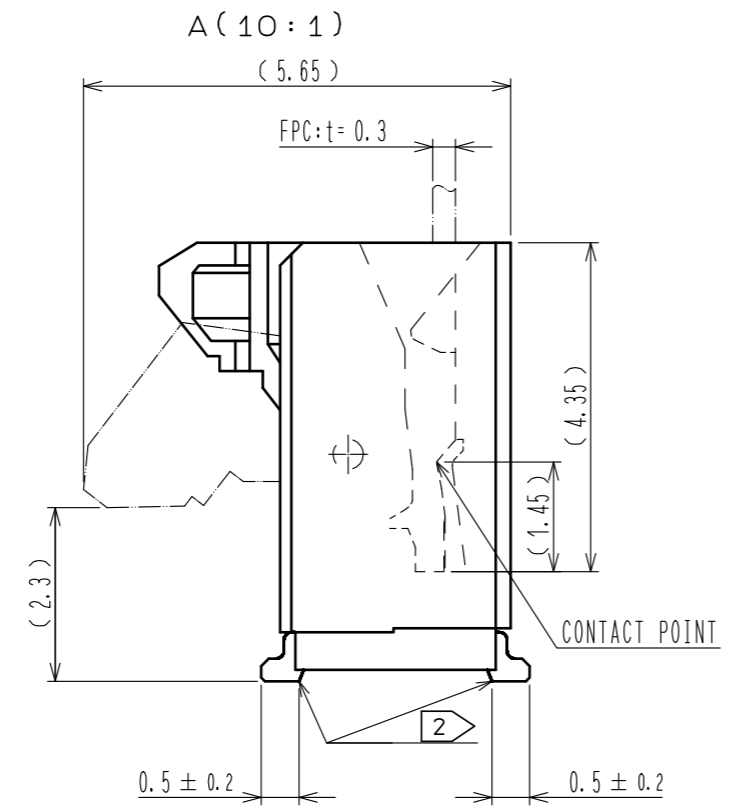
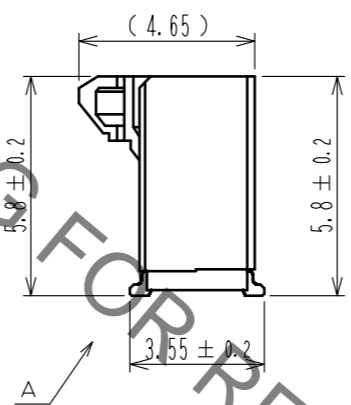
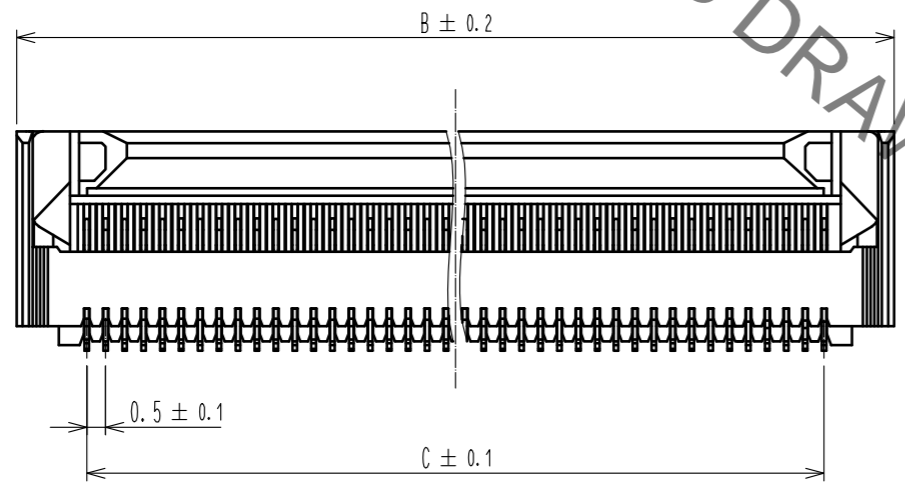
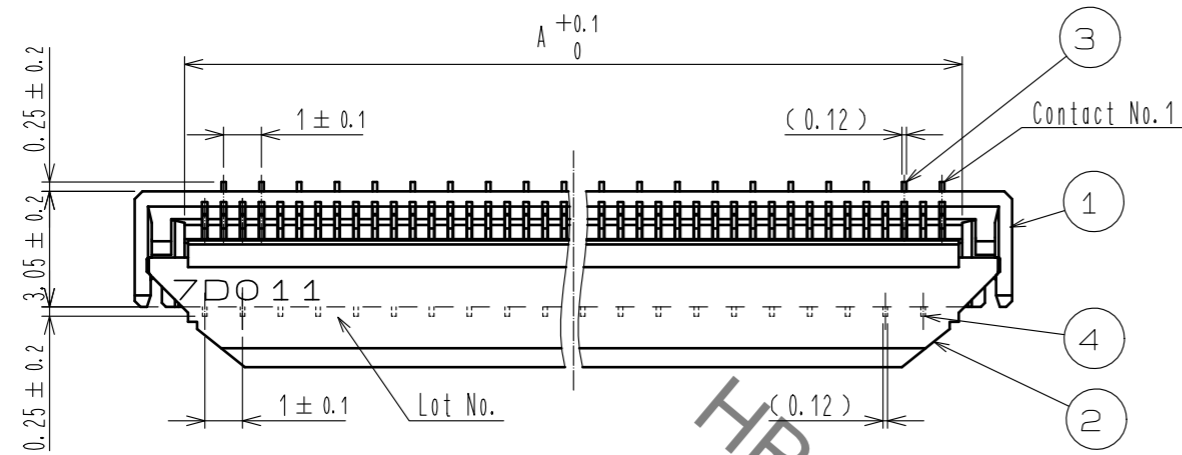

- NOTES 1. The dimension in parentheses are for reference.
 2. Lead CO-PLANARITY shall be 0.1 MAX.
 3. See dimension table in the appendix.
 4. This product satisfies halogen free requirements defined as 900ppm maximum chlorine, 900ppm maximum bromine, and 1500ppm maximum total of chlorine and bromine.
 5. 'n' represents the number of contacts.

HRS DRAWING FOR REFERENCE

4	PHOSPHOR BRONZE	(CONTACT AREA- LEAD) GOLD PLATING 0.05µm MIN. OVER NICKEL 1µm MIN. (OTHER) NICKEL 1µm MIN.			
3	PHOSPHOR BRONZE	(CONTACT AREA- LEAD) GOLD PLATING 0.05µm MIN. OVER NICKEL 1µm MIN. (OTHER) NICKEL 1µm MIN.	8	(CONNECTOR)	
2	LCP	(BLACK)	6	POLYESTER	
1	LCP	(BEIGE)	5	POLYSTYRENE	
NO.	MATERIAL	FINISH . REMARKS	NO.	MATERIAL	FINISH . REMARKS
UNITS		SCALE	COUNT	DESCRIPTION OF REVISIONS	
mm		5 : 1	8	DIS-F-00006690	
DESIGNED			DESIGNED	CHECKED	DATE
TA. SUZUKI			TA. SUZUKI	HS. HIRAHARA	20201012
APPROVED : NF. MIYAZAKI			20141224	DRAWING NO. EDC-159298-00-05	
CHECKED : HS. SAKAMOTO			20141224	PART NO. FH40-**S-0.5SV	
DESIGNED : RT. IKEDA			20141224	CODE NO. CL580	
DRAWN : RK. OGASAWARA			20141222		

Dec.1.2021 Copyright 2021 HIROSE ELECTRIC CO., LTD. All Rights Reserved.
 In case of consideration for using Automotive equipment / device which demand high reliability, kindly contact our sales window correspondents.

RECOMMENDED PCB MOUNTING PATTERN

NUMBER OF CONTACTS: EVEN NUMBER

NUMBER OF CONTACTS: ODD NUMBER

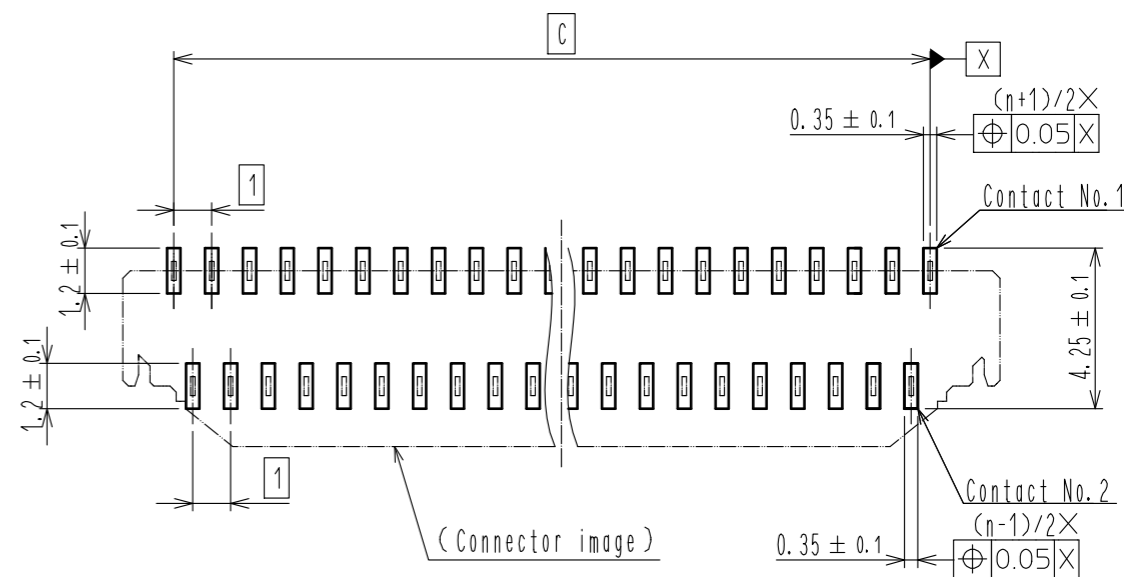
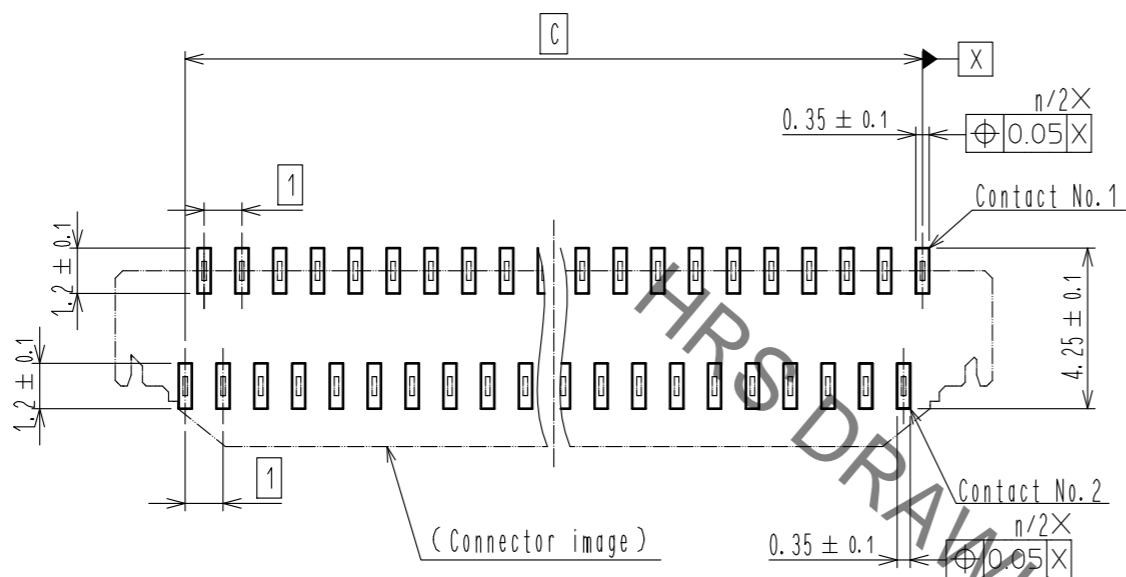

RECOMMENDED STENCIL PATTERN
 (RECOMMENDED STENCIL THICKNESS : t=0.15)

NUMBER OF CONTACTS: EVEN NUMBER

NUMBER OF CONTACTS: ODD NUMBER

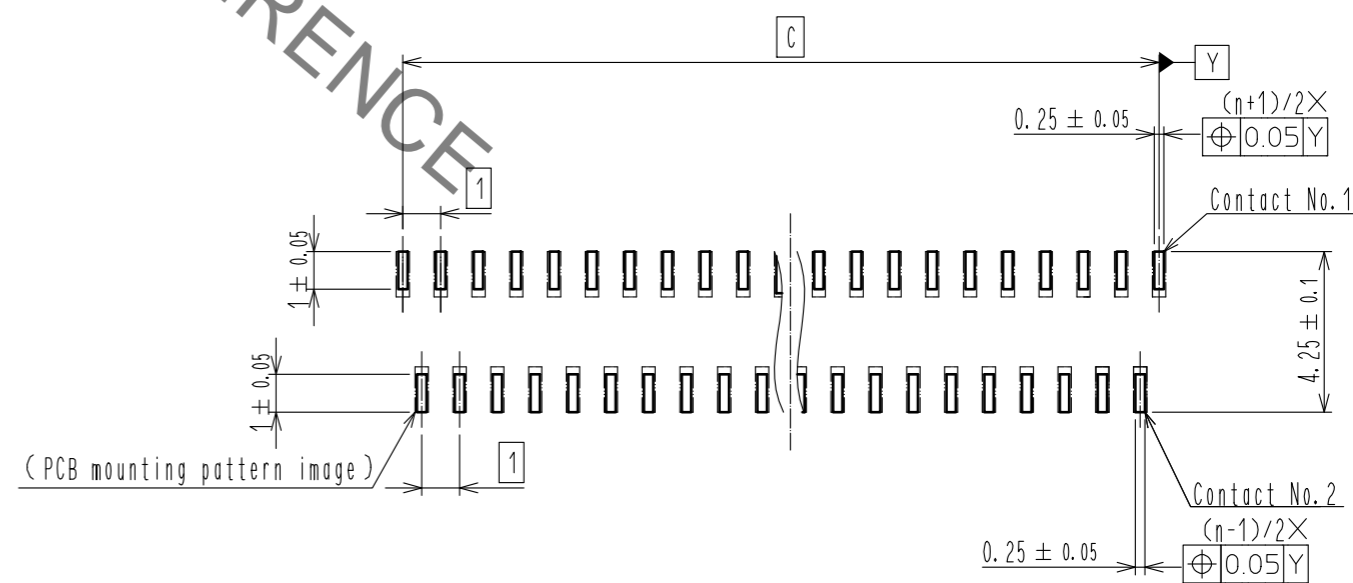
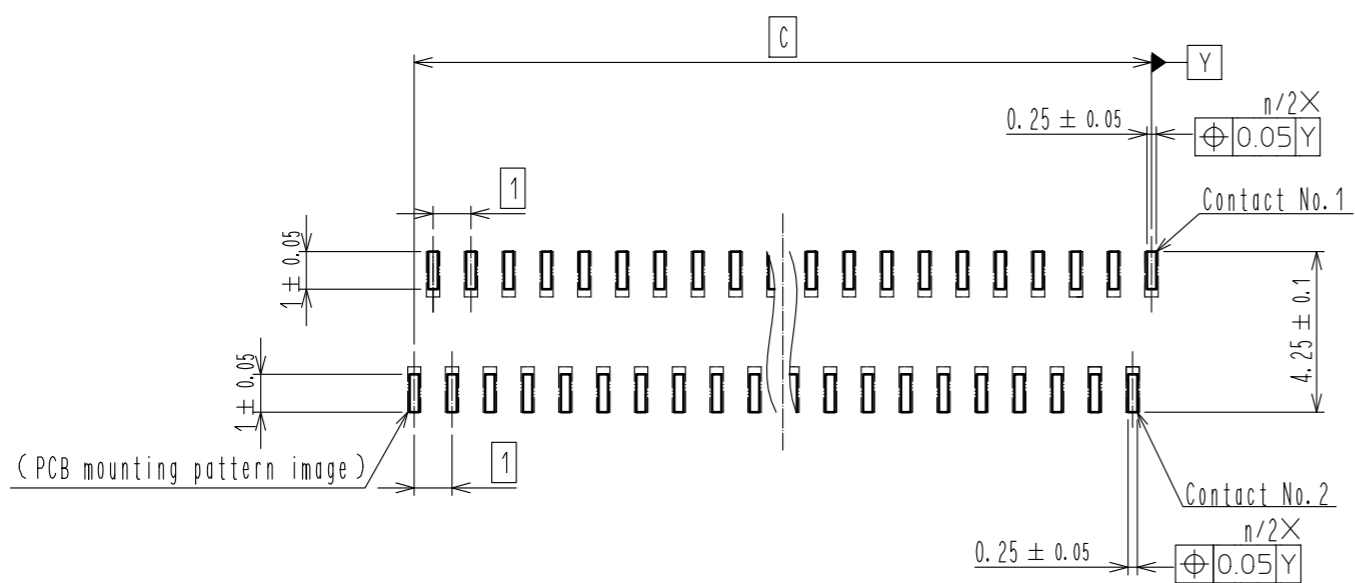

HRS	DRAWING NO.	EDC-159298-00-05
	PART NO.	FH40-**S-0.5SV
	CODE NO.	CL580
	2/9	

Dec.1.2021 Copyright 2021 HIROSE ELECTRIC CO., LTD. All Rights Reserved.
 In case of consideration for using Automotive equipment / device which demand high reliability, kindly contact our sales window correspondents.

RECOMMENDED FPC/FFC (15:1)

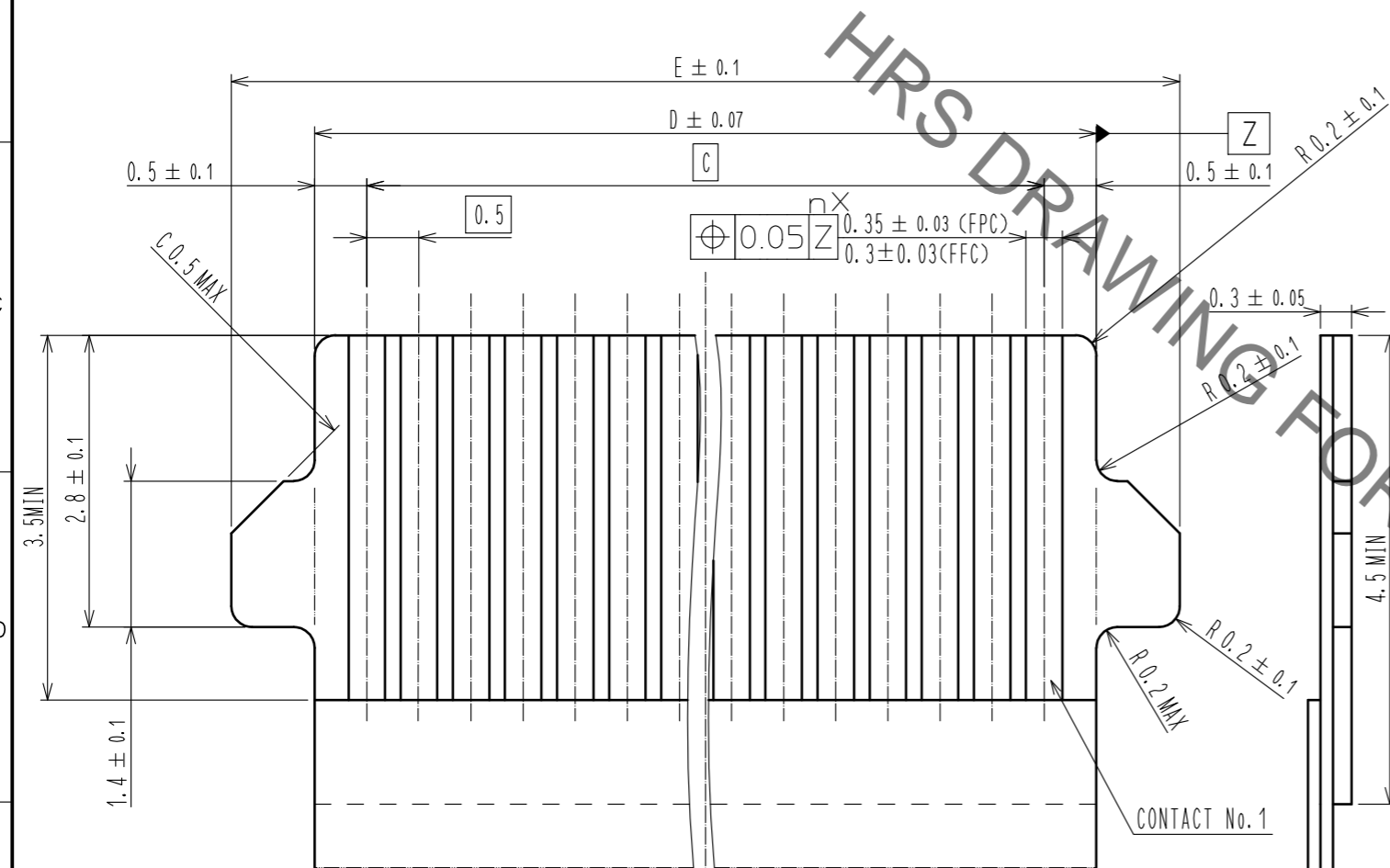

FPC CONFIGURATION (REFERENCE EXAMPLE) (SCALE:FREE)

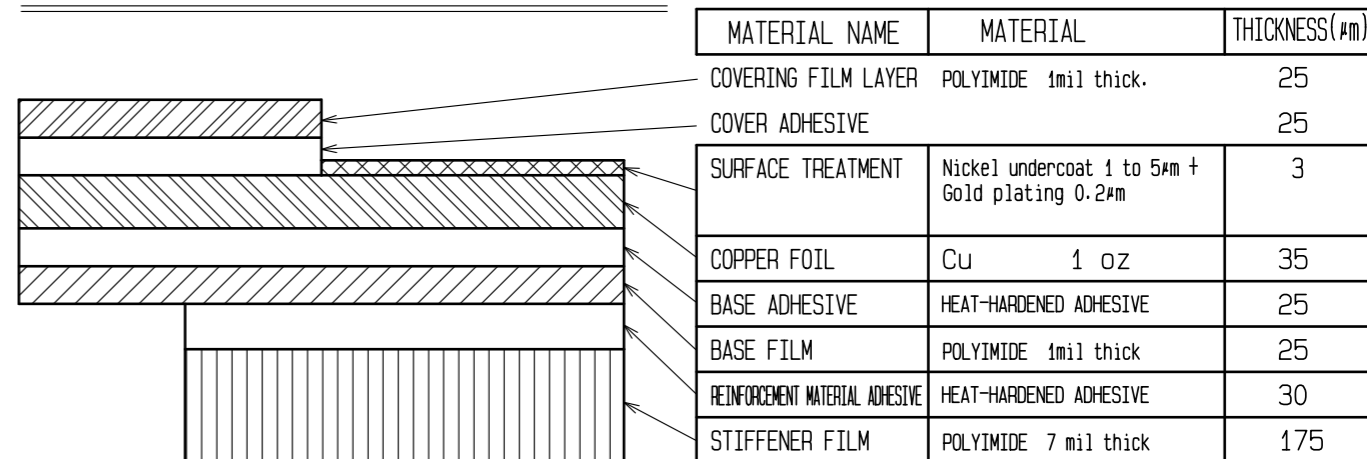

MATERIAL NAME	MATERIAL	THICKNESS(#m)
COVERING FILM LAYER	POLYIMIDE 1mil thick.	25
COVER ADHESIVE		25
SURFACE TREATMENT	Nickel undercoat 1 to 5#m + Gold plating 0.2#m	3
COPPER FOIL	Cu 1 oz	35
BASE ADHESIVE	HEAT-HARDENED ADHESIVE	25
BASE FILM	POLYIMIDE 1mil thick	25
REINFORCEMENT MATERIAL ADHESIVE	HEAT-HARDENED ADHESIVE	30
STIFFENER FILM	POLYIMIDE 7 mil thick	175

FFC CONFIGURATION (REFERENCE EXAMPLE) (SCALE:FREE)

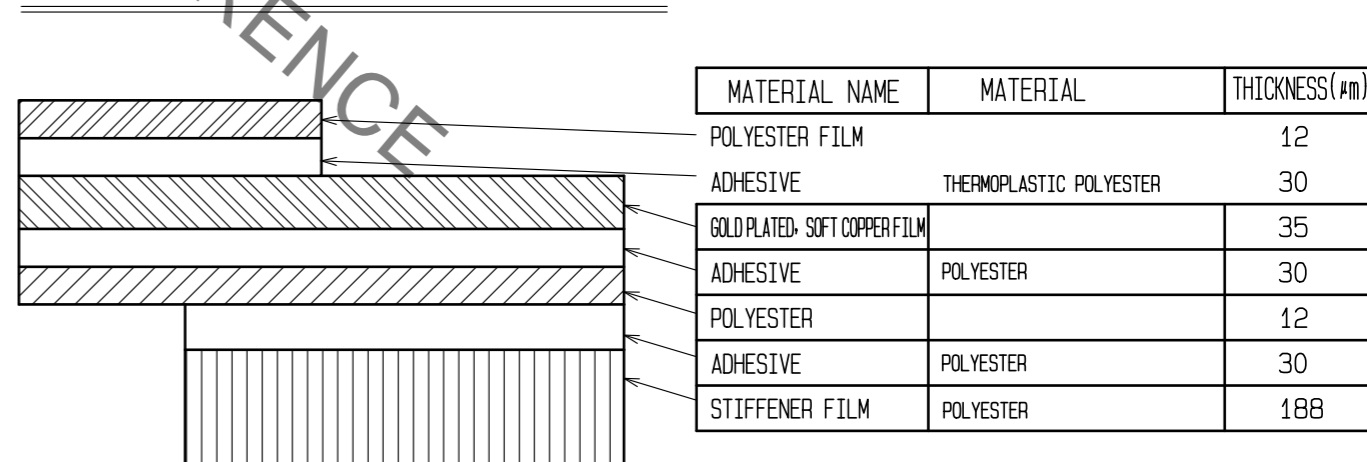

MATERIAL NAME	MATERIAL	THICKNESS(#m)
POLYESTER FILM		12
ADHESIVE	THERMOPLASTIC POLYESTER	30
GOLD PLATED SOFT COPPER FILM		35
ADHESIVE	POLYESTER	30
POLYESTER		12
ADHESIVE	POLYESTER	30
STIFFENER FILM	POLYESTER	188

HRS	DRAWING NO.	EDC-159298-00-05
	PART NO.	FH40-***S-0.5SV
	CODE NO.	CL580

3/9

Dec.1.2021 Copyright 2021 HIROSE ELECTRIC CO., LTD. All Rights Reserved.
In case of consideration for using Automotive equipment / device which demand high reliability, kindly contact our sales window correspondents.

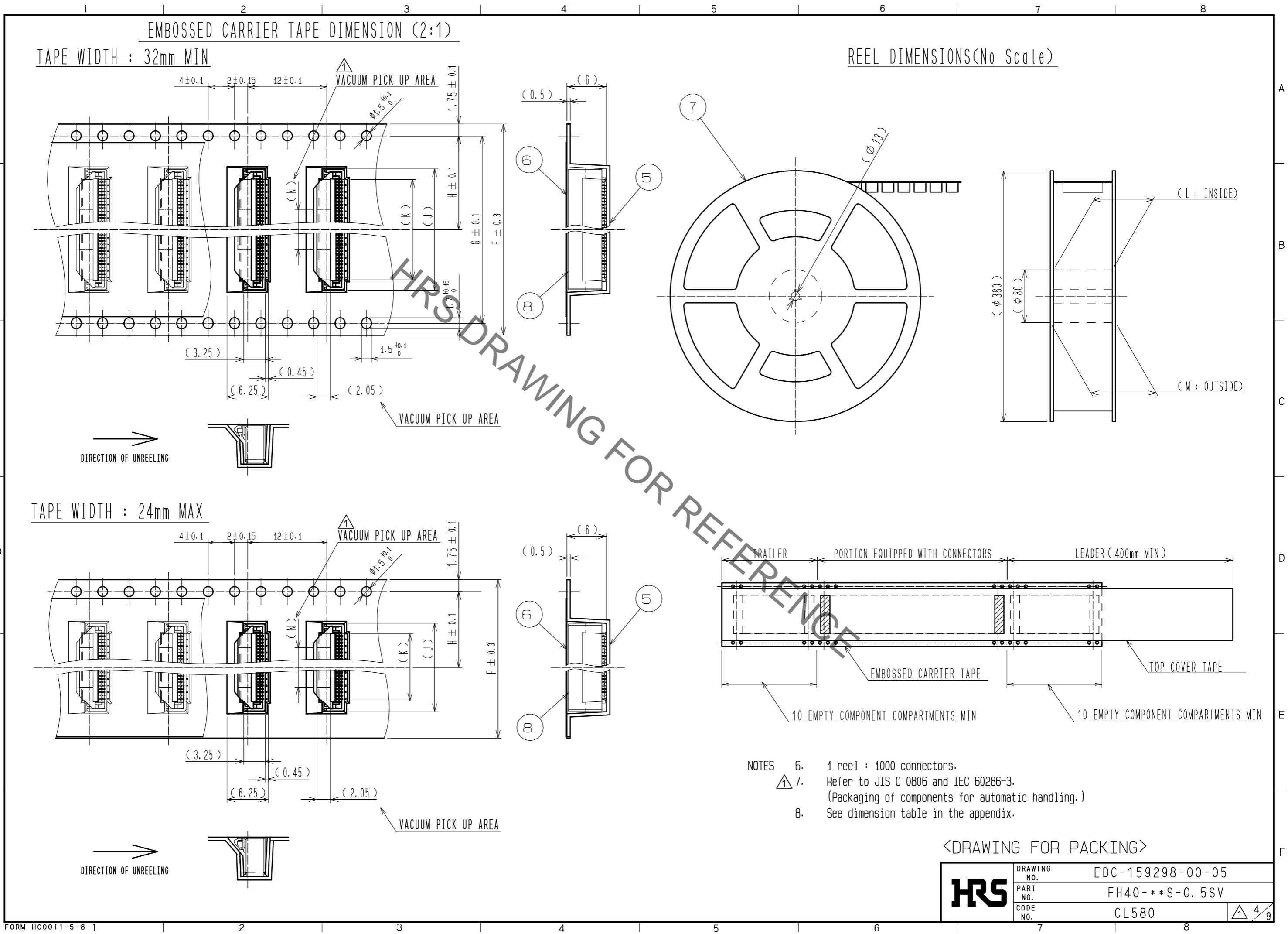



- NOTES
- 6. 1 reel : 1000 connectors.
 - 7. Refer to JIS C 0806 and IEC 60286-3.
(Packaging of components for automatic handling.)
 - 8. See dimension table in the appendix.

<DRAWING FOR PACKING>

HR	DRAWING NO.	EDC-159298-00-05
	PART NO.	FH40-**S-0.5SV
	CODE NO.	CL580
		4/9

Dec.1.2021 Copyright 2021 HIROSE ELECTRIC CO., LTD. All Rights Reserved.
 In case of consideration for using Automotive equipment / device which demand high reliability, kindly contact our sales window correspondents.

PART NO.	CODE NO.	NUMBER OF CONTACT	DIMENSION OF CONNECTOR, PCB MOUNTING PATTERN, STENCIL PATTERN AND FFC/FPC					DIMENSION OF DRAWING FOR PACKING 							
			A	B	C	D	E	F	G	H	J	K	L	M	N
FH40-10S-0.5SV	CL580-2104-6	10	5.57	8.2	4.5	5.5	7.1	16	—	7.5	8.4	5.2	17.4	21.4	3.5
FH40-20S-0.5SV	CL580-2105-9	20	10.57	13.2	9.5	10.5	12.1	24	—	11.5	13.4	10.2	25.4	29.4	6
FH40-24S-0.5SV	CL580-2106-1	24	12.57	15.2	11.5	12.5	14.1	24	—	11.5	15.4	12.2	25.4	29.4	6
FH40-30S-0.5SV	CL580-2108-7	30	15.57	18.2	14.5	15.5	17.1	32	28.4	14.2	18.4	15.2	33.4	37.4	6
FH40-40S-0.5SV	CL580-2107-4	40	20.57	23.2	19.5	20.5	22.1	44	40.4	20.2	23.4	20.2	45.4	49.4	6
FH40-45S-0.5SV	CL580-2101-8	45	23.07	25.7	22	23	24.6	44	40.4	20.2	25.9	22.7	45.4	49.4	6
FH40-50S-0.5SV	CL580-2100-5	50	25.57	28.2	24.5	25.5	27.1	44	40.4	20.2	28.4	25.2	45.4	49.4	6
FH40-60S-0.5SV	CL580-2109-0	60	30.57	33.2	29.5	30.5	32.1	56	52.4	26.2	33.4	30.2	57.4	61.4	6
FH40-64S-0.5SV	CL580-2102-0	64	32.57	35.2	31.5	32.5	34.1	56	52.4	26.2	35.4	32.2	57.4	61.4	6
FH40-80S-0.5SV	CL580-2103-3	80	40.57	43.2	39.5	40.5	42.1	56	52.4	26.2	43.4	40.2	57.4	61.4	8

HRS	DRAWING NO.	EDC-159298-00-05
	PART NO.	FH40-***S-0.5SV
	CODE NO.	CL580
		 5/9

Dec.1.2021 Copyright 2021 HIROSE ELECTRIC CO., LTD. All Rights Reserved.
In case of consideration for using Automotive equipment / device which demand high reliability, kindly contact our sales window correspondents.

This connector requires delicate and careful handling.
To prevent connector/FPC breakage and contact failure (mating failure, FPC pattern breakage, etc),
read through the instructions shown below and handle the connector properly.
This instruction manual is applicable to usage with FPC/FFC.

[Connector part nomenclature]

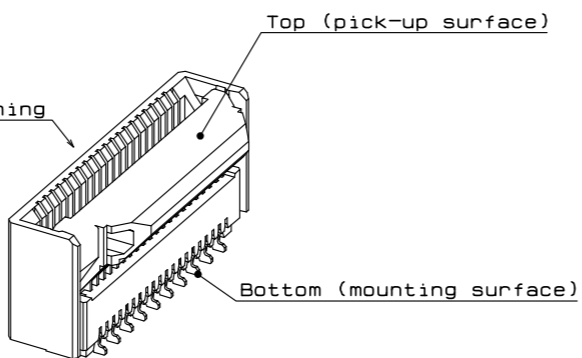
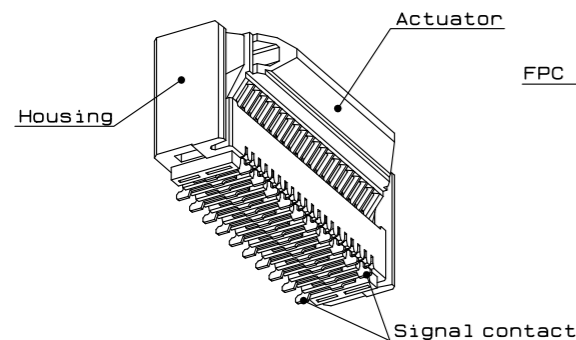

[Operation and precautions]

1. Initial condition

The product is supplied with the actuator closed.
Actuator does not have to be operated before inserting FPC.

[Caution]

- Do not open the actuator when the FPC is not inserted(Example 1).
- Do not insert FPC or operate actuator before mounting(Example 1).

Example 1)

X NG

- When delivered -

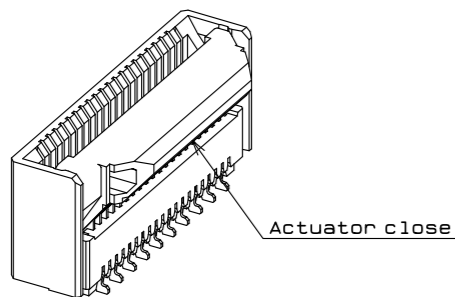

Before mounting

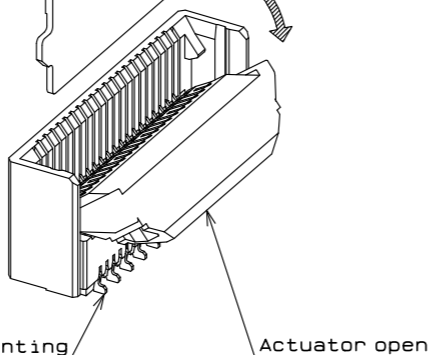

2. How to insert FPC

Insert the FPC into the connector opening vertically to the PCB surface(Example 2).
Insert it properly to the very end.

[Caution]

- Make sure the actuator is closed when inserting the FPC.
Do not insert the FPC when the actuator is open(Example 3).
- While actuator is open, it is structured so that FPC can't be inserted,
but if it is forced to insert FPC it will cause breakage.
- Do not insert the FPC when the actuator is pressed from above a finger(Example 4).
- Insert the FPC pattern surface on the opposite side of the actuator operation part (Example 5).
- Align both sides of the tip of FPC vertically to the sides of the connector opening and insert straight forward(Example 6).
- Do not twist the FPC to up and down or right and left or an angle(Example 7, 8).
- Do not open actuator with fingers when insert FPC(Example 9).

Example 2)

O OK

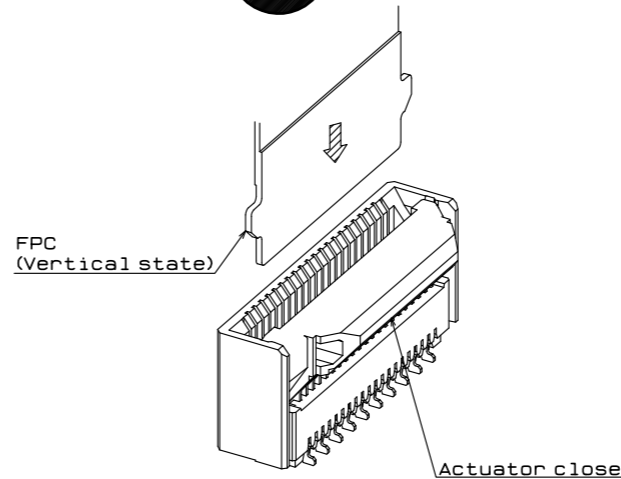

Example 3)

X NG

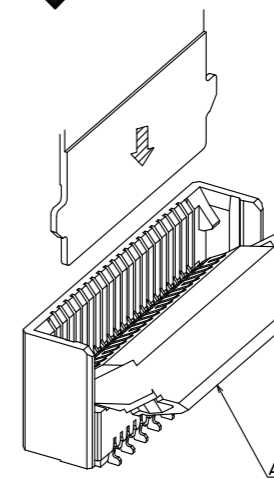

Example 4)

X NG

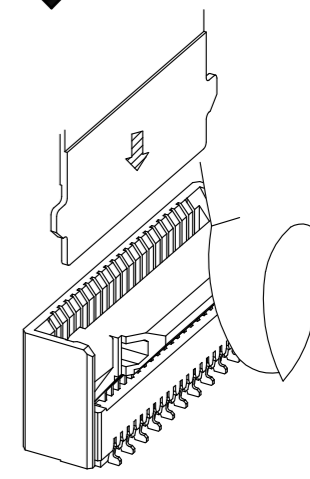

Example 5)

O OK

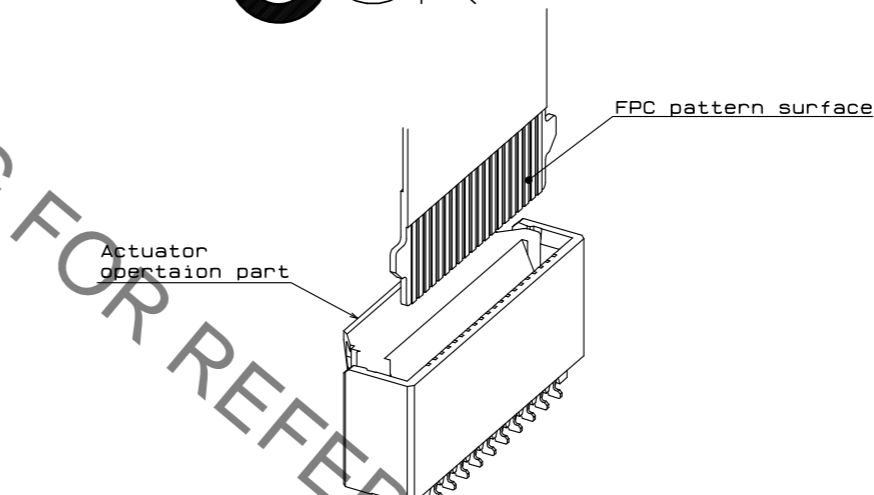

Example 6)

O OK

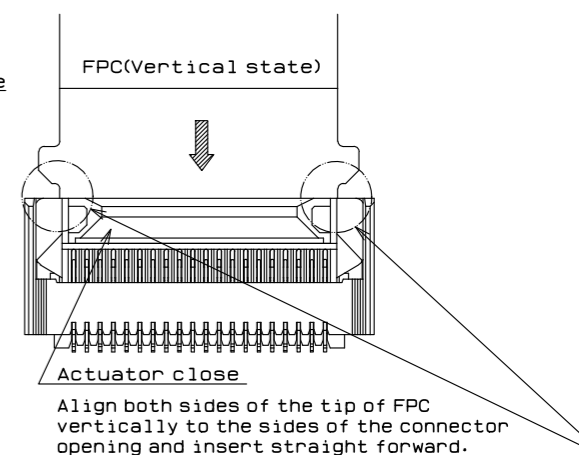

Example 7)

X NG

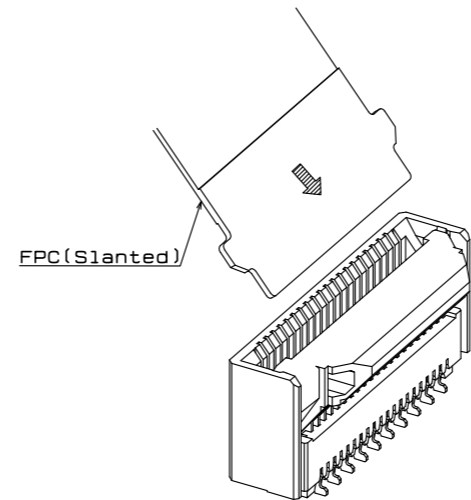

Example 8)

X NG

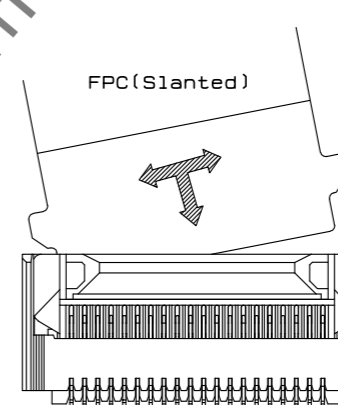

Example 9)

X NG

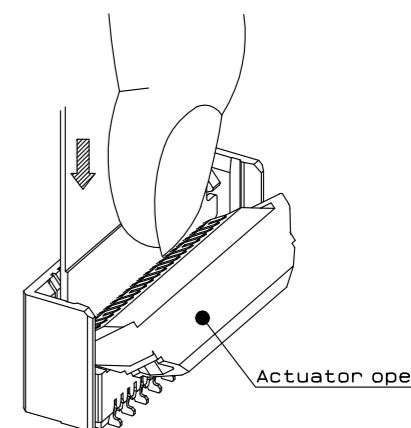

△ <Instruction manual(1)>

HRS	DRAWING NO.	EDC-159298-00-05
	PART NO.	FH40-**S-0.5SV
	CODE NO.	CL580
		6/9

Dec.1.2021 Copyright 2021 HIROSE ELECTRIC CO., LTD. All Rights Reserved.
In case of consideration for using Automotive equipment / device which demand high reliability, kindly contact our sales window correspondents.

3. FPC insertion check
 Make sure that the FPC tabs are located in proper position after FPC insertion (Example 10).
 (The FPC position is to be aligned by the protrusion of the housing.)

[Caution]
 - Do not insert the FPC at an angle and/or stop it before insertion is completed (Example 11, 12).

Example 10)

OK

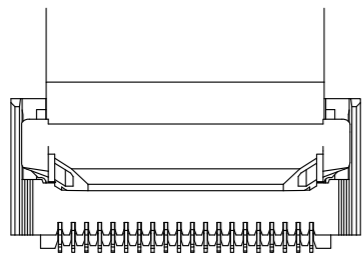

FPC is completely inserted to the end.

Example 11)

NG

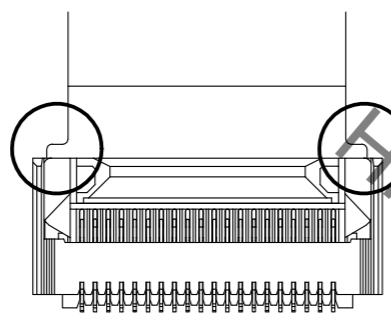

Insertion of FPC is shallow and not fully inserted to the end.

Example 12)

NG

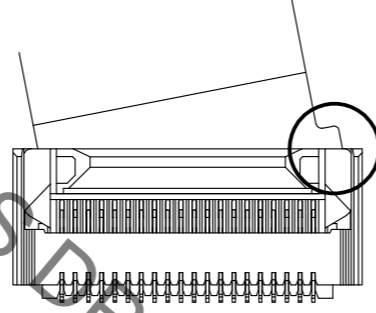

FPC is inserted in slanted angle and not fully inserted to the end.

4. Use of the actuator (open/close)
 Slowly flip down the actuator to the lock (Example 13).
 Slowly flip up the actuator to release the lock (Example 14).

[Caution]
 - To open/close the actuator, operate at the center of the actuator (Example 15).
 - To open/close the actuator, do not operate the actuator at one end only (Example 16).
 - The actuator is opened up to the movable limit, 90 degree. Do not open the actuator beyond the specified degree or apply excess force to the actuator (Example 17).
 - Do not pick the actuator to lift and pull it (Example 18).
 - Operate the actuator by hand without using sharp tool such as Tweezers. (Example 19).
 - Do not apply excess force to the actuator during the operation (Example 20).

Example 13)

OK

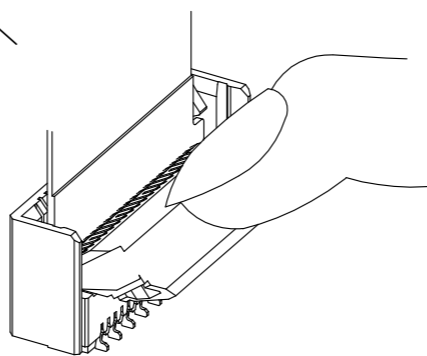
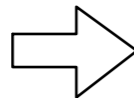
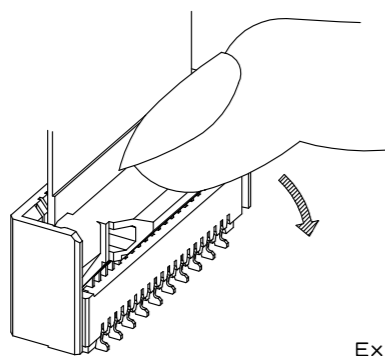

Example 14)

OK

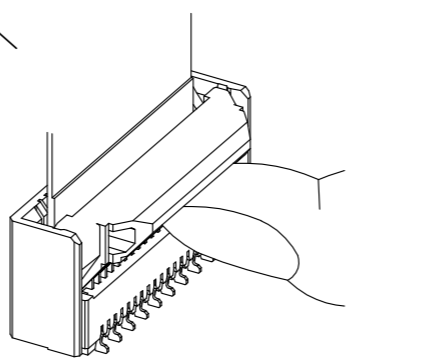
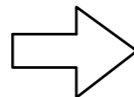
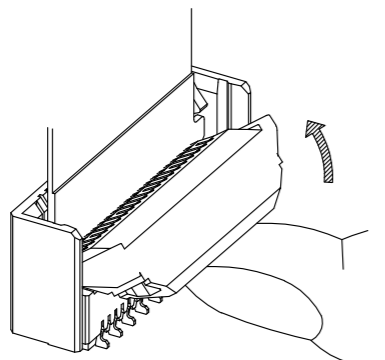

Example 15)

OK

Operate the actuator at the center

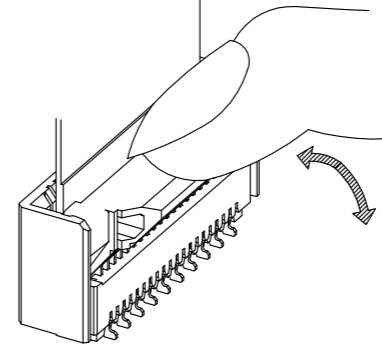

Example 16)

NG

Do not operate the actuator at one end only

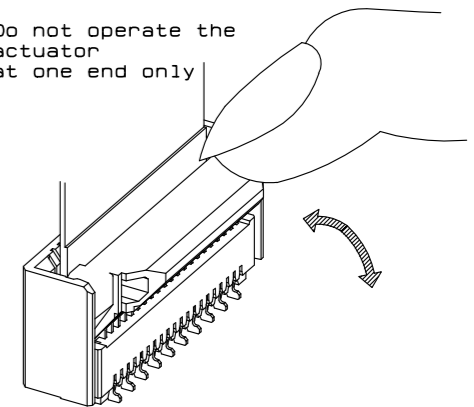

Example 17)

NG

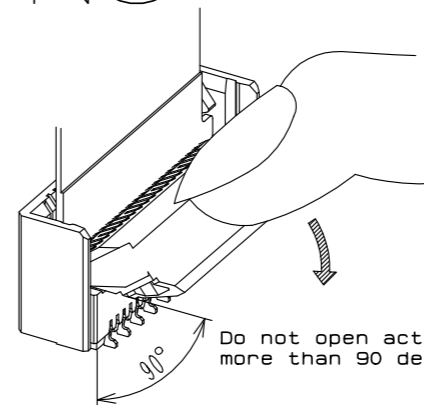

Do not open actuator more than 90 degree.

Example 18)

NG

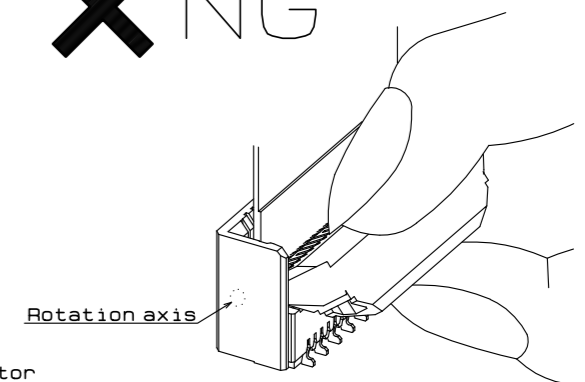

The excess stress which is applied on the rotation axis, could cause breakage.

Example 19)

NG

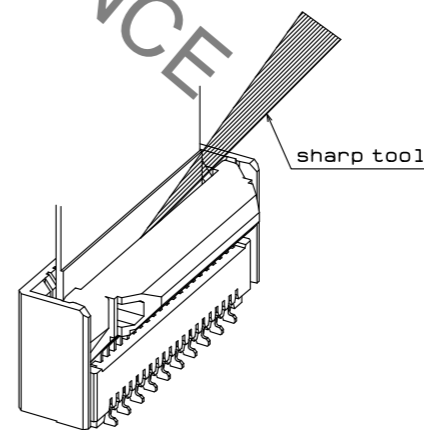

sharp tool

Example 20)

NG

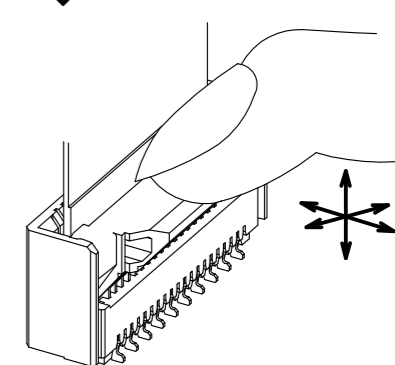

Do not apply excess force to the actuator during the operation.

△ <Instruction manual(2)>

HRS	DRAWING NO.	EDC-159298-00-05	7/9
	PART NO.	FH40-**S-0.5SV	
	CODE NO.	CL580	

Dec.1.2021 Copyright 2021 HIROSE ELECTRIC CO., LTD. All Rights Reserved.
In case of consideration for using Automotive equipment / device which demand high reliability, kindly contact our sales window correspondents.

5. How to remove FPC

After flip up the actuator to the fully opened position vertically withdraw the FPC(Example 21).

[Caution]

- Do not attempt to pull the FPC without unlocking the housing(Example 22).
- After forcibly remove FPC, retention force of FPC may decrease.
- This connector has a temporary FPC holding structure with the housing. For FPC removal, do not pull out the FPC other than in the vertically direction of the PCB(Example 23).

[Precautions for component layout]

Depending on a FPC rounding, a load is applied to the connector, and a contact failure may occur. To prevent a failure, take the following notes into a consideration during mechanism design.

[Caution]

- When fixing FPC after FPC cabling, avoid pulling FPC, and route the wire FPC with slack. In this regard, the stiffener is vertical to the PCB(Example 24).
- Avoid applying forces to FPC in vertical or horizontal directions. Do not bend the FPC excessively near the connector during use, or it may cause contact failure or FPC breakage. Stabilizing the FPC is recommended(Example 25, 26).
- Do not mount other components or enclosure touching to the FPC underneath the FPC stiffener(Example 27).
- Make adjustments with the FPC manufacturer for FPC bending performance and wire breakage.
- Keep a sufficient FPC insertion space in the stage of the layout in order to avoid incorrect FPC insertion. Appropriate FPC length and component layout are recommended for assembly ease. Too short FPC length makes assembly difficult.
- Keep spaces for the locking lever movement and its operation for PCB design and component layout.

Example 21)

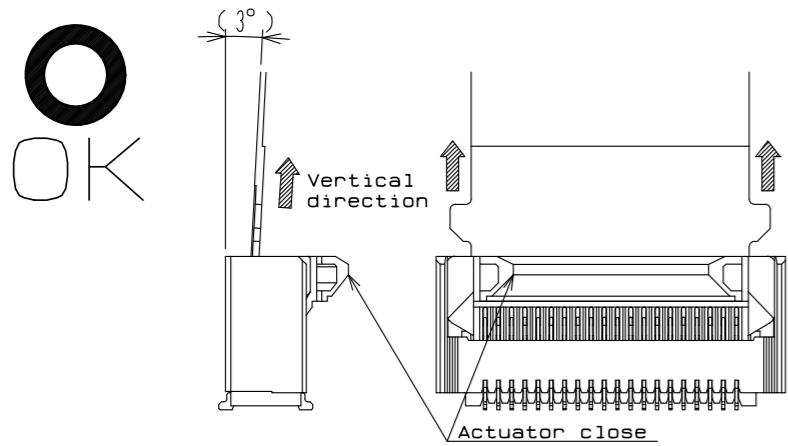

Example 22)

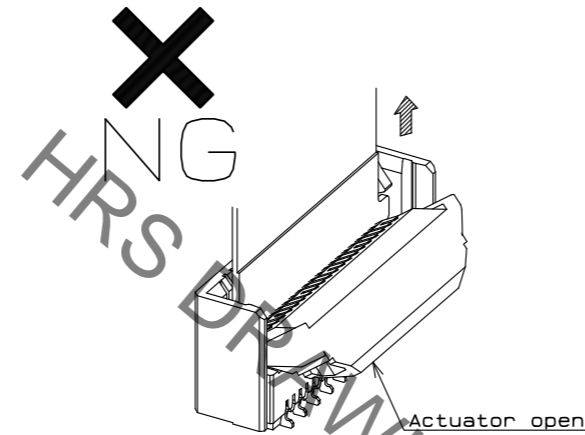

Example 23)

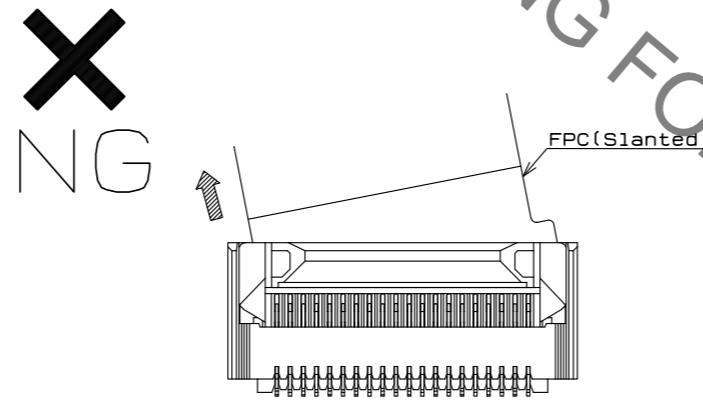
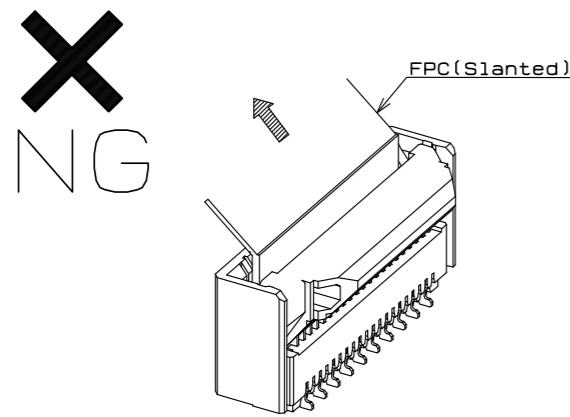

Example 24)

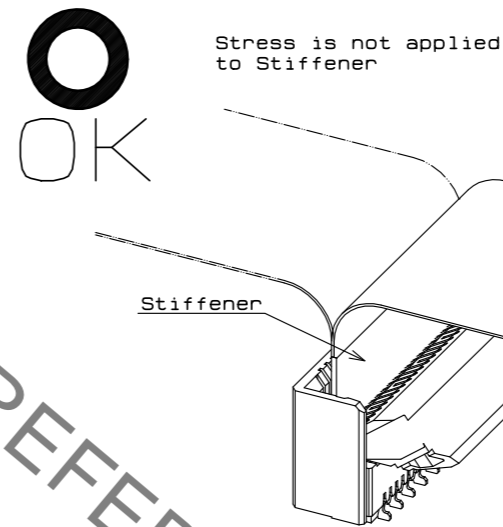

Example 25)

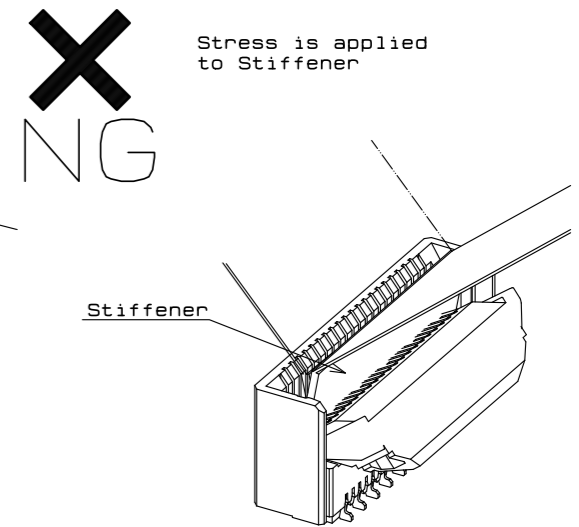

Example 26)

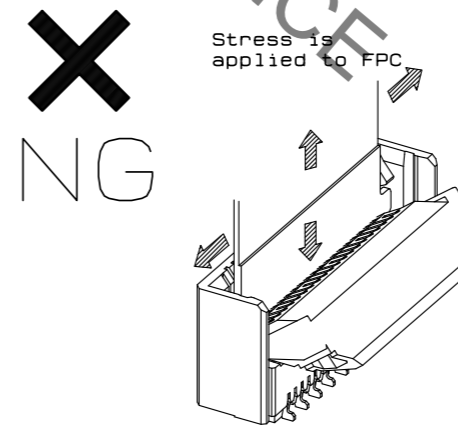

Example 27)

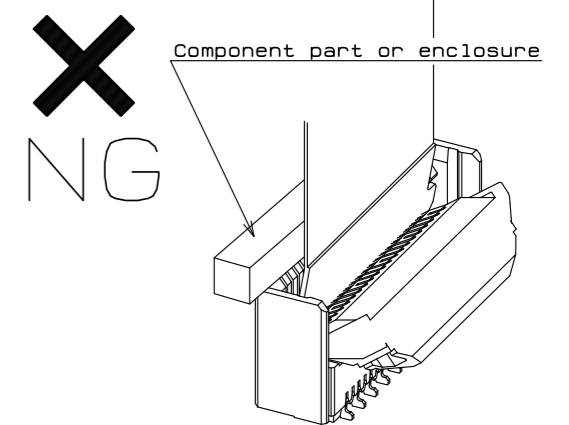

△ <Instruction manual(3)>

HRS	DRAWING NO.	EDC-159298-00-05
	PART NO.	FH40-**S-0.5SV
	CODE NO.	CL580
		△ 8/9

Dec.1.2021 Copyright 2021 HIROSE ELECTRIC CO., LTD. All Rights Reserved.
In case of consideration for using Automotive equipment / device which demand high reliability, kindly contact our sales window correspondents.

[Instructions for mounting on the PCB]

Follow the instructions shown below when mounting on the PCB.

[Caution]

- Refer to recommended layouts on the page 1 for PCB and stencil pattern.
- Shorter pattern width than the recommended PCB dimension, could cause solder wicking and/or flux penetration.
- Larger pattern than the recommended stencil dimension, could cause solder wicking and/or flux penetration.
- Clearance underneath the contact lead and the housing is very small. In case solder resist and/or silk screening are applied on PCB underneath the connector, verify the thickness, or it could push up the connector bottom and may cause soldering defect and/or insufficient fillet formation.
- Apply reflow temperature profile within the specified conditions. In individual applications, the actual temperature may vary, depending on solder paste type, volume/thickness and PCB size/thickness. Consult your solder paste and equipment manufacturer for specific recommendations.
- Prevent warpage of PCB, where possible, since it can cause soldering failure even with 0.1 mm max coplanarity.
- When mounting on the flexible board, please make sure to put a stiffener on the backside of the flexible board. We recommend a glass epoxy material with the thickness of 0.3 mm min.
- Do not add 1.0 N or greater external force when unroll or pick and place the connector etc, or it may get broken.

[Instructions for PCB handling after mounting the connector]

Follow the instructions shown below when mounting on the PCB.

[Caution]

- Splitting a large PCB into several pieces
 - Screwing the PCB
- During the handling described above, do not exert an excessive force on the PCB. Otherwise, the connector may become defective.
- The warp of a 100 mm wide PCB should be 1.0 mm or less. The warp of PCB suffers stress on connector and the connector may become defective (Example 27).

Example 27)

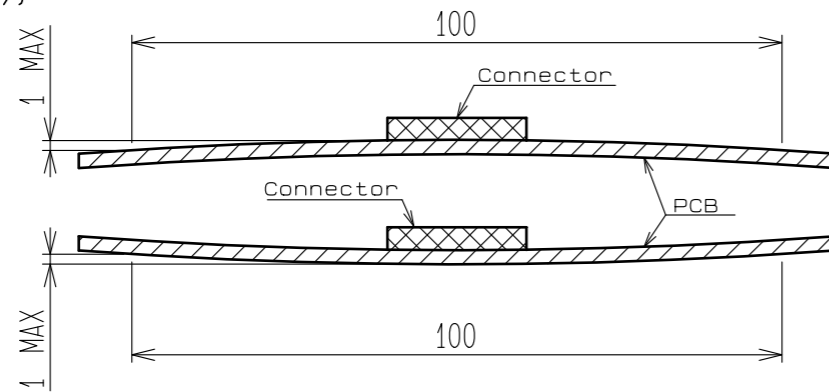

[Instructions on manual soldering]

Follow the instructions shown below when soldering the connector manually during repair work, etc.

[Caution]

- Do not perform manual soldering with the FPC inserted into the connector.
 - Do not heat the connector excessively. Be very careful not to let the soldering iron contact any parts other than connector leads. Otherwise, the connector may be deformed or melt.
 - Do not supply excessive solder (or flux).
- If excessive solder (or flux) is supplied on the terminals, solder or flux may adhere to the contacts, resulting in poor contact. Supplying excessive solder to the metal fittings may hinder locking lever rotation, resulting in breakage of the connector.

[Recommended reflow temperature profile]

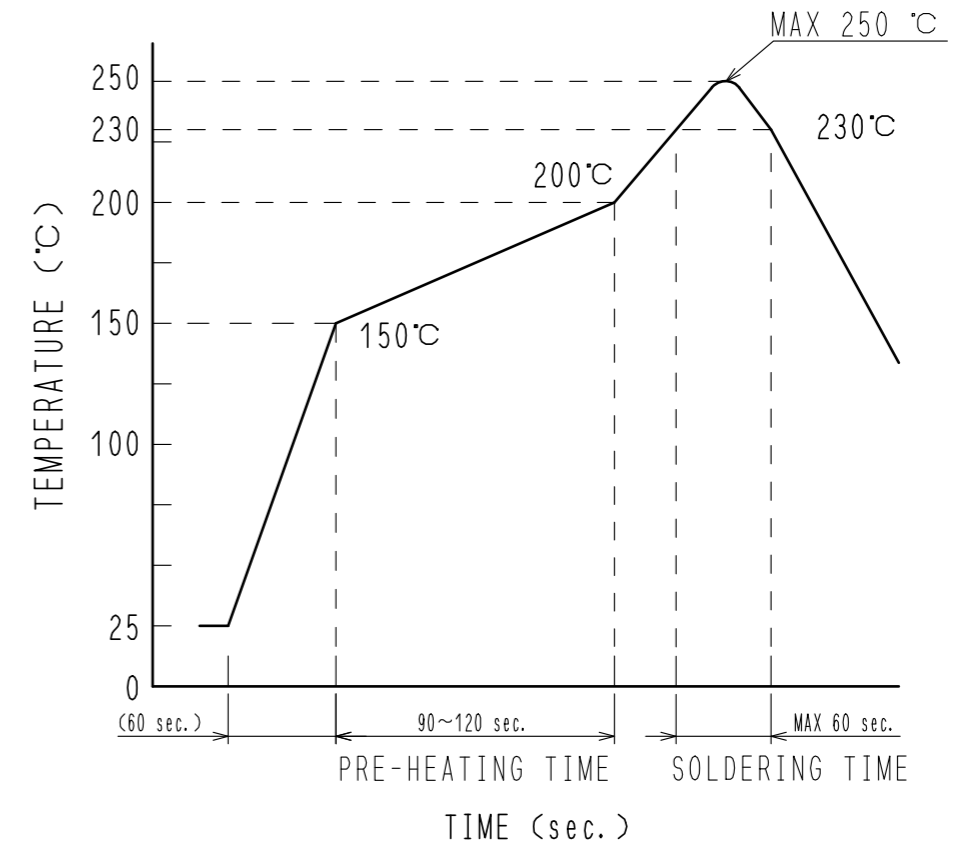

- Reflow method: IR reflow
 Number of reflow cycles: 2 cycles MAX.
 1) Reflow time
 Duration above 230°C: 60 sec MAX.
 (Peak temperature: 250°C MAX)
 2) Pre-heat time
 Pre-heat temperature (MIN): 150°C
 Pre-heat temperature (MAX): 200°C
 Pre-heat time: 90~120 sec.

△ <Instruction manual(4)>

HRS	DRAWING NO.	EDC-159298-00-05
	PART NO.	FH40-**S-0.5SV
	CODE NO.	CL580

1/9

X-ON Electronics

Largest Supplier of Electrical and Electronic Components

Click to view similar products for [FFC & FPC Connectors](#) category:

Click to view products by [Hirose](#) manufacturer:

Other Similar products are found below :

[K-FC20](#) [FH29B-80S-0.2SHW\(99\)](#) [FPH-2022G](#) [AYF332735](#) [52610-1075](#) [52610-1275](#) [52610-1934](#) [501864-3091-TR225](#) [086222026001800](#)
[52610-0675](#) [62684-36210E9ALF](#) [52746-1671-TR250](#) [10051922-2810EHLF](#) [6-520415-9](#) [SFV6R-1STE9HLF](#) [XF3M-2915-1B-R100](#)
[1658549-1](#) [46214008010800](#) [AYF534065TA](#) [AYF351525](#) [086212040340800+](#) [AYF530365TA](#) [67000-014LF](#) [67000-004LF](#)
[006207341915000+](#) [DS1020-19RT1D](#) [67000-003LF](#) [67000-011LF](#) [67000-016LF](#) [HFW14R-2STE9LF](#) [SFV32R-2STBE9HLF](#) [SFW12R-](#)
[5STE9LF](#) [SFW18R-1STAE9LF](#) [SFW4R-5STE9LF](#) [52807-0430](#) [046283021002868+](#) [THD1015-8CL-SN](#) [67000-006LF](#) [502250-8027](#)
[104267-9617](#) [66987-011LF](#) [AYF362535](#) [F0501-T-50-20T-R](#) [HFW8S-2STAE1HLF](#) [67000-008LF](#) [67000-012LF](#) [ECC576069EU](#) [F1002-B-](#)
[20-20T-R](#) [HFW15S-2STAE1HLF](#) [0781271110](#)