

Jan.1.2022 Copyright 2022 HIROSE ELECTRIC CO., LTD. All Rights Reserved.  
In case of consideration for using Automotive equipment / device which demand high reliability, kindly contact our sales window correspondents.

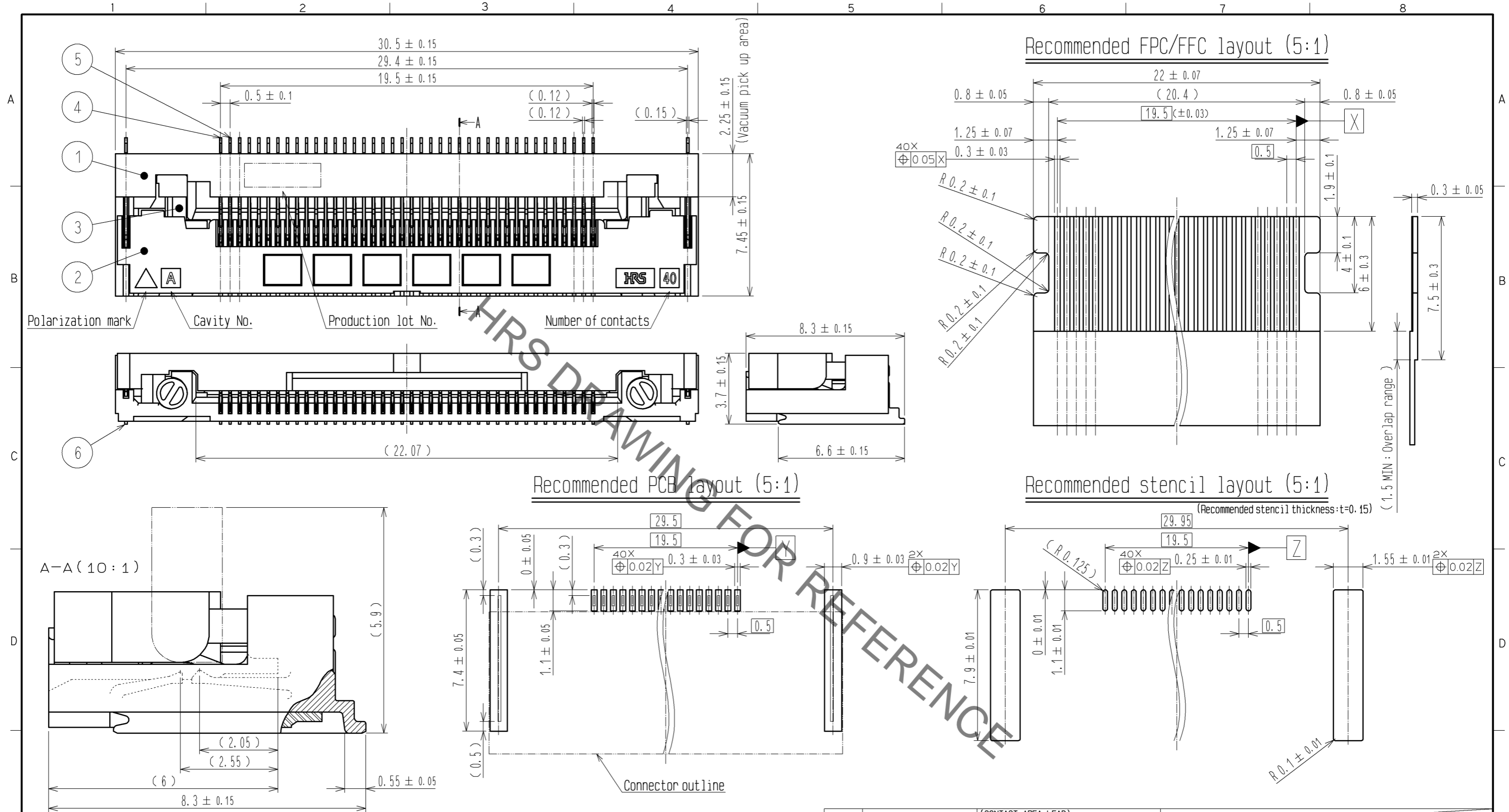

- Notes
- The dimensions in parentheses are for reference dimensions.
  - Lead coplanarity including metal fittings shall be 0.1mm max.
  - Delivered as tape and reel package.  
See packaging specification for details.
  - Material core-outs and/or slits may be added on the insulator body or actuator.  
Location or configuration will not affect form, fit or function.
  - Slight dark spots or material discoloration will not affect form, fit or function.
  - This product satisfies halogen free requirements defined as 900ppm maximum chlorine, 900ppm maximum bromine, and 1500ppm maximum total of chlorine and bromine.

5	PHOSPHOR BRONZE	(CONTACT AREA-LEAD) GOLD PLATING 0.03µm MIN OVER NICKEL 1µm MIN. (OTHER) NICKEL PLATING 1µm MIN.	10	(CONNECTOR)	
4	PHOSPHOR BRONZE	(CONTACT AREA-LEAD) GOLD PLATING 0.03µm MIN OVER NICKEL 1µm MIN. (OTHER) NICKEL PLATING 1µm MIN.	9	POLYSTYRENE	
3	LCP	BLACK UL94V-0	8	POLYESTER	
2	LCP	BLACK UL94V-0	7	POLYSTYRENE	
1	LCP	GRAY UL94V-0	6	PHOSPHOR BRONZE (PLATED MATERIAL)	TIN PLATING(REFLOW FINISHED)1µm MIN OVER COPPER 0.3mm MIN.
NO.	MATERIAL	FINISH . REMARKS	NO.	MATERIAL	FINISH . REMARKS

  

UNITS mm		SCALE 5 : 1	COUNT 	DESCRIPTION OF REVISIONS	DESIGNED	CHECKED	DATE
APPROVED : MO. ISHIDA 13.09.02				DRAWING NO. EDC3-347196-00			
CHECKED : YN. TAKASHITA 13.09.02				PART NO. FH50-40S-0.5SH			
DESIGNED : SU. SUNAGA 13.08.30				CODE NO. CL580-4004-2-00			
DRAWN : SU. SUNAGA 13.08.30							

Jan.1.2022 Copyright 2022 HIROSE ELECTRIC CO., LTD. All Rights Reserved.  
 In case of consideration for using Automotive equipment / device which demand high reliability, kindly contact our sales window correspondents.

Embossed carrier tape dimensions (2:1)

Reel dimensions (SCALE:FREE)

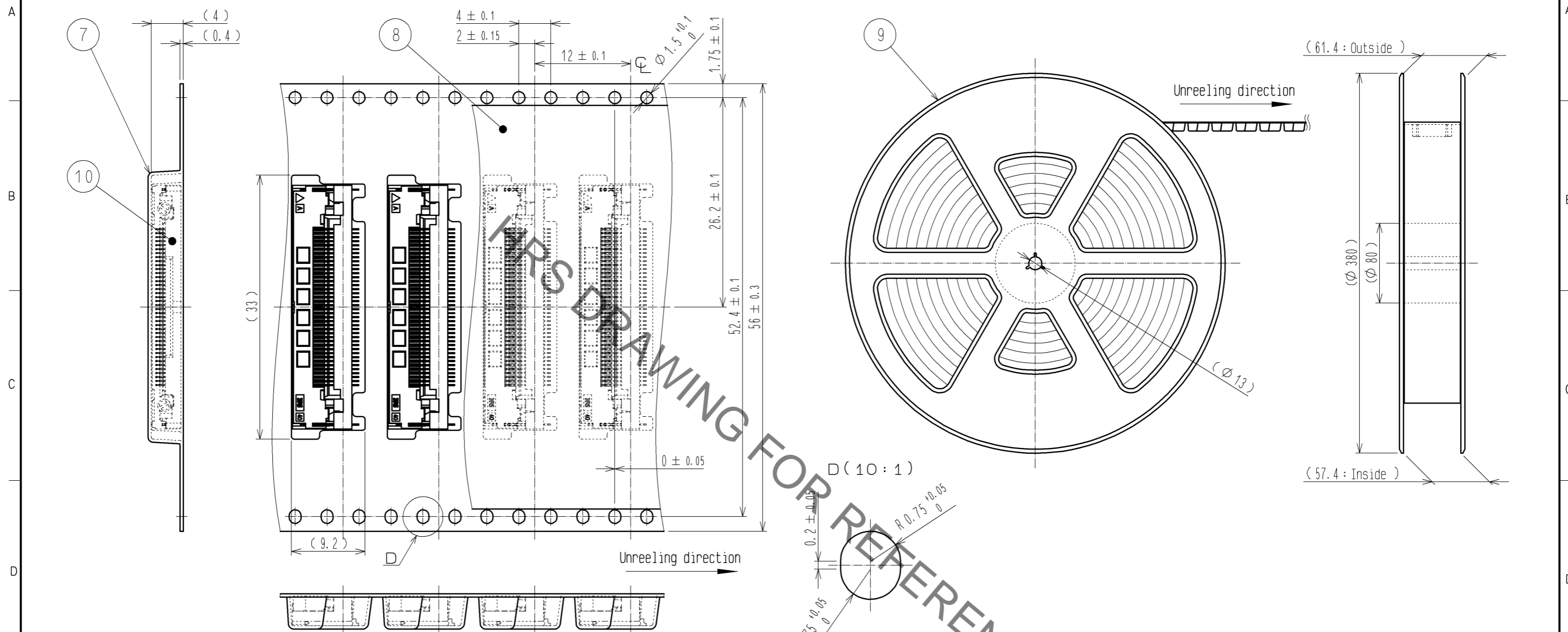

Leader, trailer dimensions (SCALE:FREE)

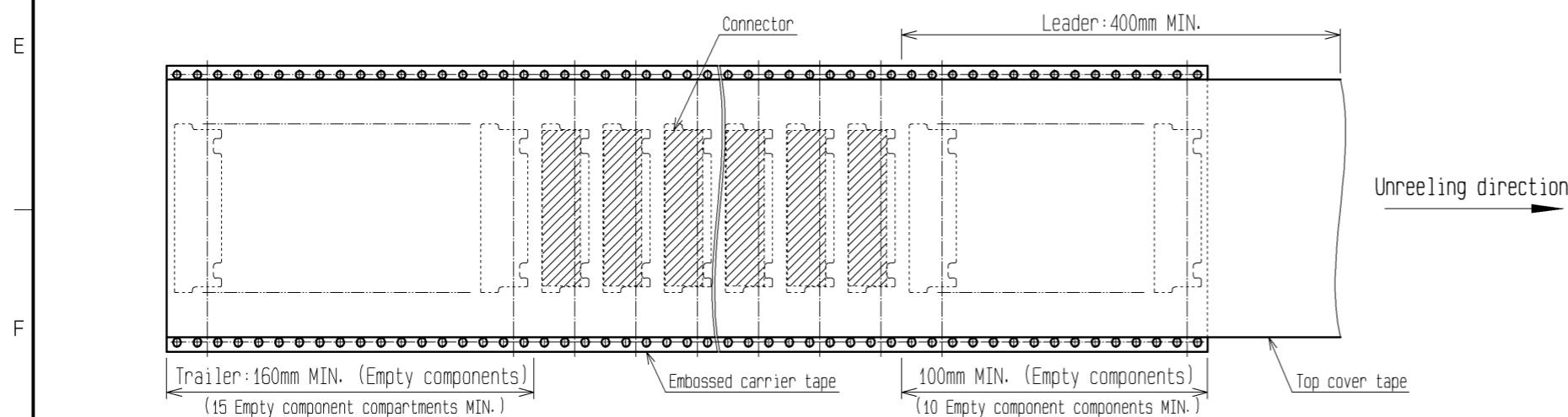

- Notes
- 7. Per reel : 1,000 connectors.
  - 8. Refer to JIS C 0806 (packaging of components for automatic handling.)

< PACKAGING SPECIFICATION >

<b>HRS</b>	DRAWING NO.	EDC3-347196-00	△ 2/7
	PART NO.	FH50-40S-0.5SH	
	CODE NO.	CL580-4004-2-00	

Jan.1.2022 Copyright 2022 HIROSE ELECTRIC CO., LTD. All Rights Reserved.  
In case of consideration for using Automotive equipment / device which demand high reliability, kindly contact our sales window correspondents.

This connector requires careful handling.  
Follow recommendations given below to prevent connector/FPC/FFC breakage and contact failure (mating failure, FPC/FFC pattern breakage, etc.).  
The numerical values shown are not part of the connector specification.

[Operations and Precautions]

1. How to operate the actuator

Apply load to rotate the actuator by 90 degrees. [Fig.1]

[Caution]

- ◆ Do not insert any tools or fingernails inside the connector while opening it as this may cause damage to the contacts. [Fig.2]
- ◆ The actuator is opened up to the movable limit, 90 degrees. Do not open the actuator beyond the specified degree or apply excess force to the actuator. [Fig.3]
- ◆ Operate the actuator by hand without using sharp tool such as tweezers. [Fig.4]
- ◆ Do not attempt to dislodge the open actuator as this may cause damage to the connector. [Fig.5]

2. How to insert FPC/FFC

Insert the FPC/FFC into the connector parallel to the PCB plane and perpendicular to the connector after opening the actuator by 90 degrees.  
Insert it properly to the end. [Fig.6, Fig.7]

[Caution]

- ◆ This is a bottom contact point connector. FPC/FFC must be inserted with the exposed contact surfaces facing down.
- ◆ This connector has temporary FPC/FFC holding structure with cams on each sides of the connector. Tactile sensation generated during FPC/FFC insertion does not affect connector quality.
- ◆ Do not insert the FPC/FFC at a sharp angle as this may cause contact deformation, FPC/FFC pattern breakage or only partial insertion in the connector. [Fig.8, Fig.9]

[Fig.1]

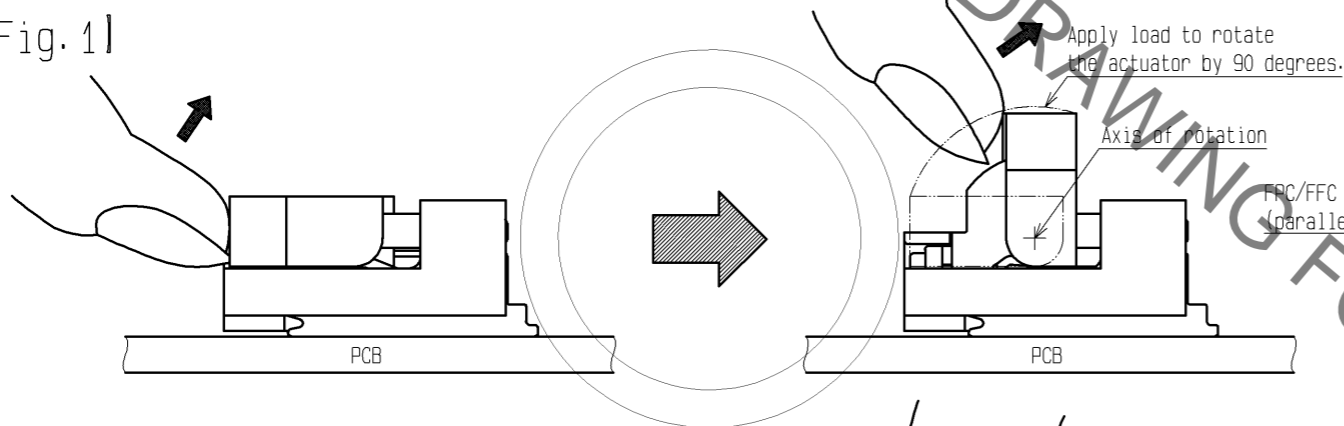

[Fig.6]

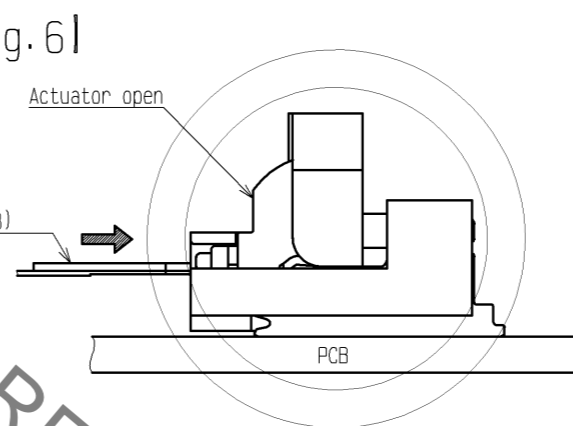

[Fig.7]

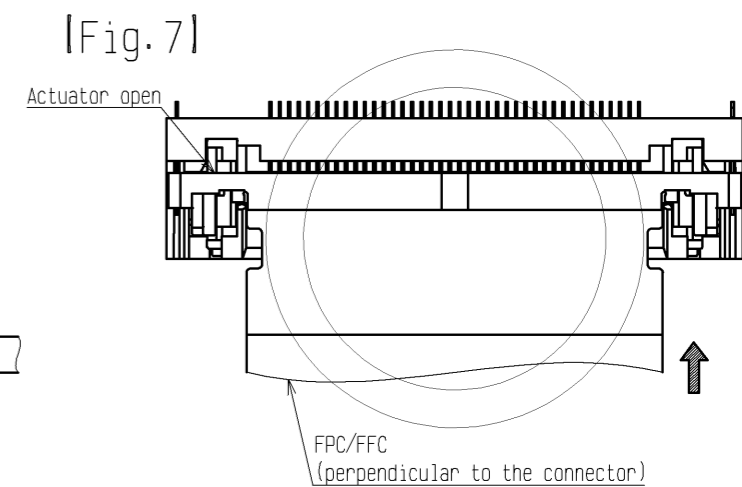

[Fig.2]

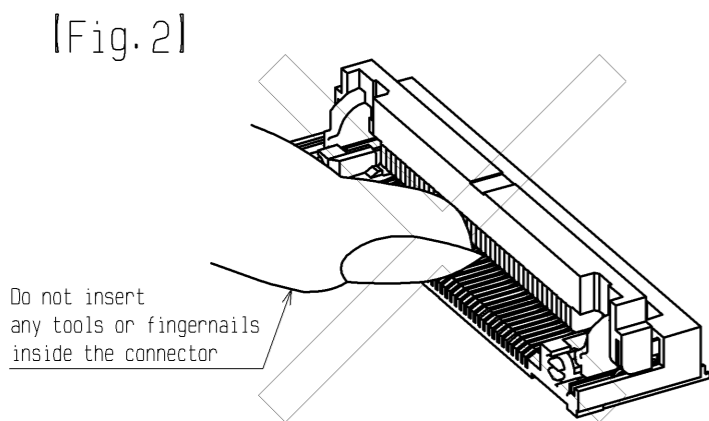

[Fig.3]

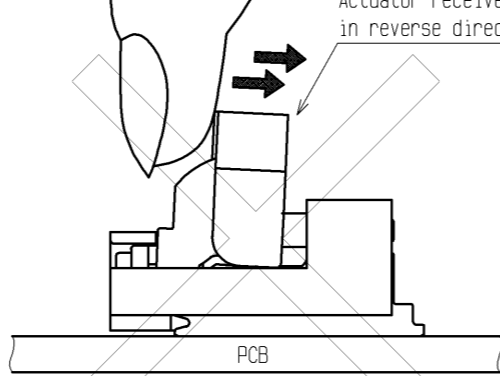

[Fig.8]

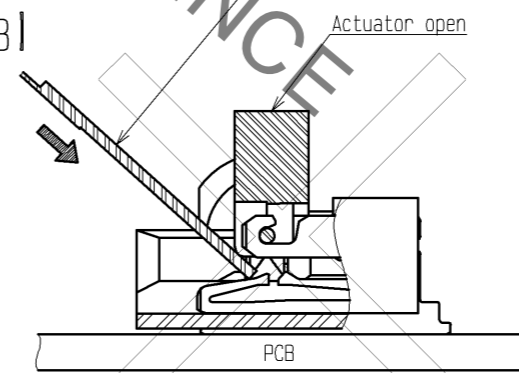

[Fig.9]

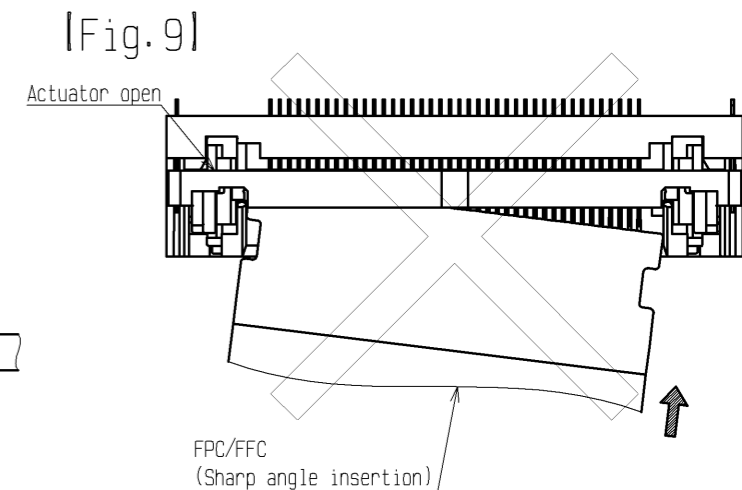

[Fig.4]

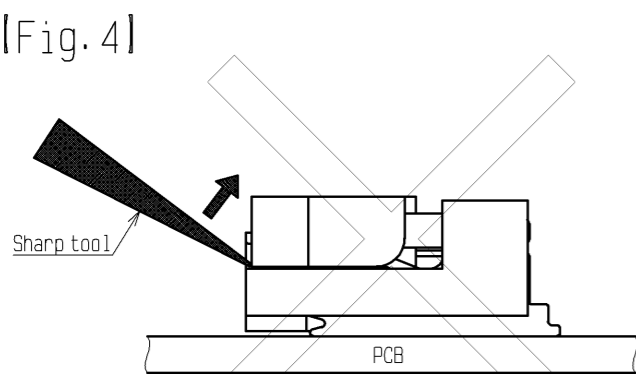

[Fig.5]

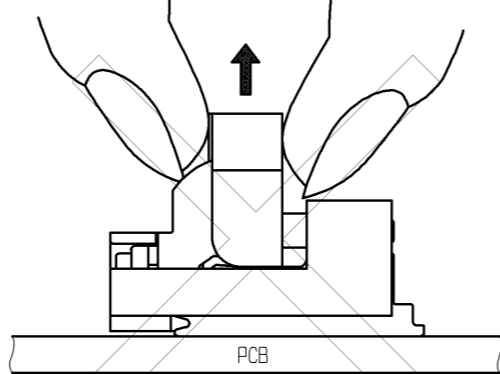

< INSTRUCTION MANUAL (1) >

<b>HRS</b>	DRAWING NO.	EDC3-347196-00
	PART NO.	FH50-40S-0.5SH
	CODE NO.	CL580-4004-2-00
		3/7

Jan.1.2022 Copyright 2022 HIROSE ELECTRIC CO., LTD. All Rights Reserved.  
In case of consideration for using Automotive equipment / device which demand high reliability, kindly contact our sales window correspondents.

### 3. How to lock

Apply load to rotate the actuator by 90 degrees after inserting the FPC/FFC to the end. [Fig.10]

#### [Caution]

- ◆ The actuator does not close if the FPC/FFC is not inserted to the end (hereinafter called "Incomplete mating"). "Incomplete mating prevention structure"
  - ◆ Do not rotate the actuator to the counter direction. Otherwise, it may break. [Fig.11]
  - ◆ Operate the actuator by hand without using sharp tool such as tweezers. [Fig.12]
  - ◆ Do not attempt to dislodge the open actuator as this may cause damage to the connector. [Fig.13]
  - ◆ Apply load to the center on the actuator to rotate it. Do not apply force to the actuator at one end only. Uneven load could twist the actuator and cause actuator breakage. [Fig.14, Fig.15]
  - ◆ Although this connector has "Incomplete mating prevention structure" of FPC/FFC, avoid forcible actuator operation in incomplete mating mode, or this could damage connector. Stop the operation and confirm the FPC/FFC positioning. When you detect incomplete mating, direction of the slit on cam indicates mode of the FPC/FFC insertion as shown in ① and ② below.
- ① If the slit on cam rotates along with closing actuator, the FPC/FFC is inserted to the end. Proceed the operation. [Fig.16]
- ② If the slit on cam remains still while the actuator is closed, the FPC/FFC is not inserted correctly. STOP the operation and confirm FPC/FFC positioning. [Fig.17]

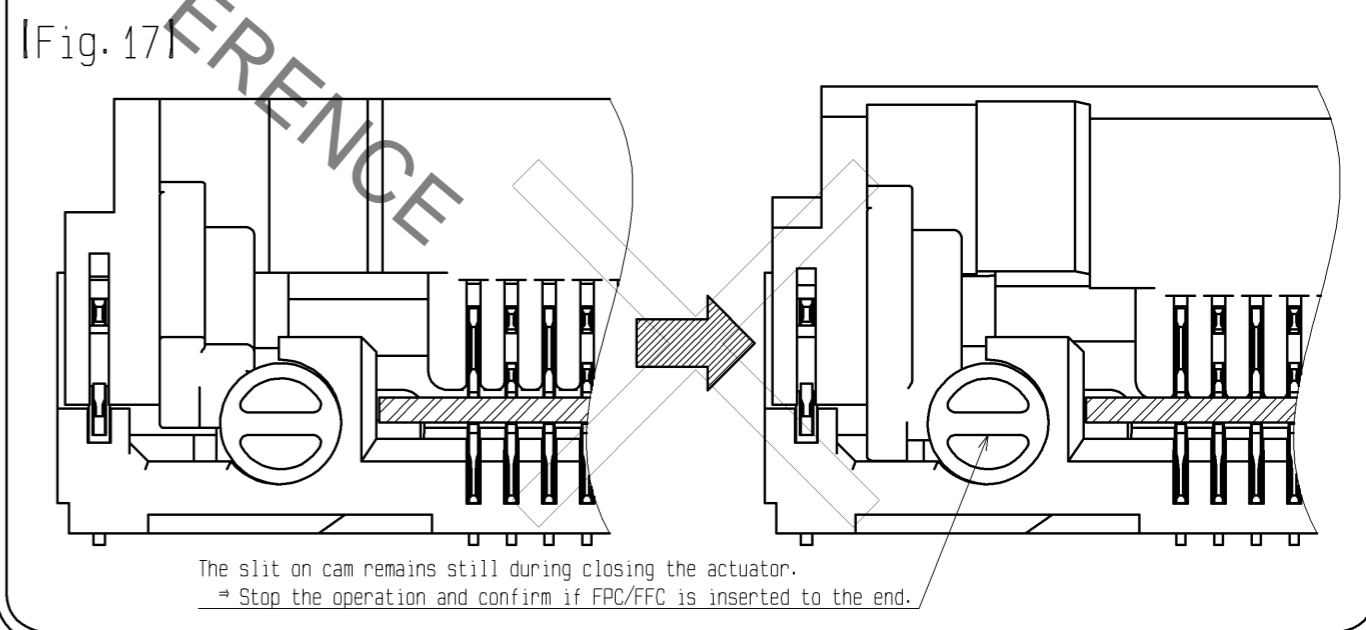
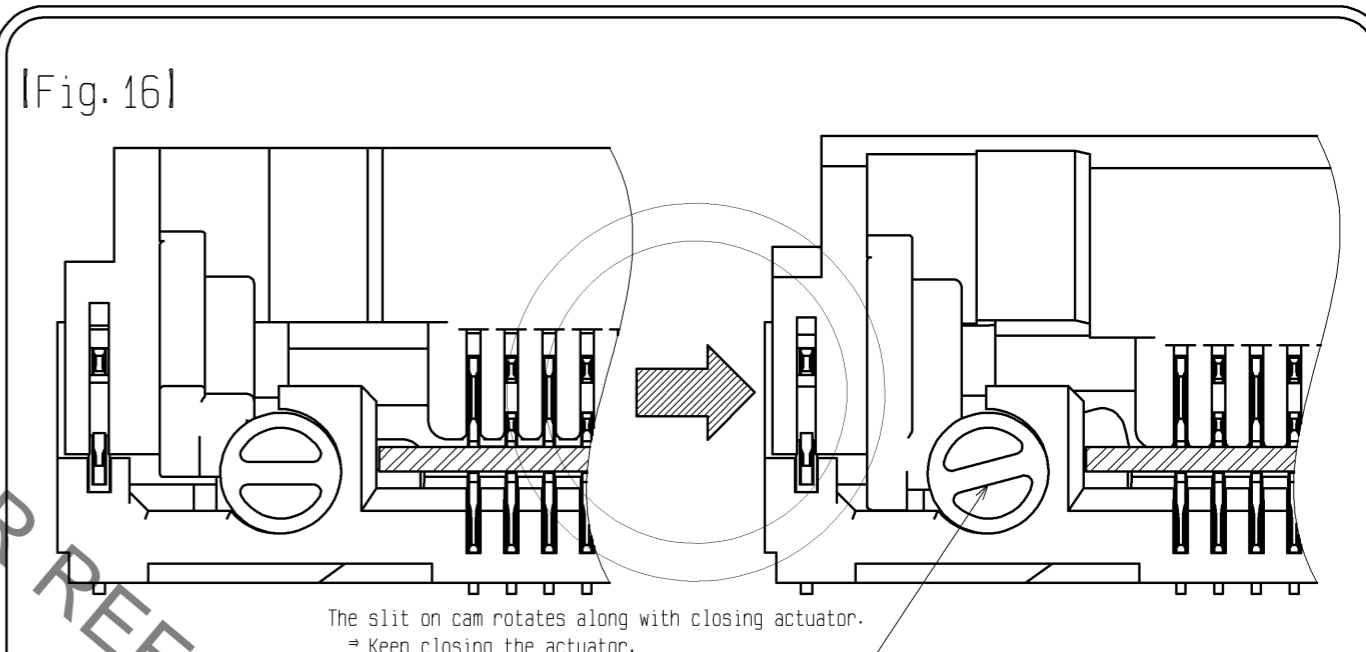
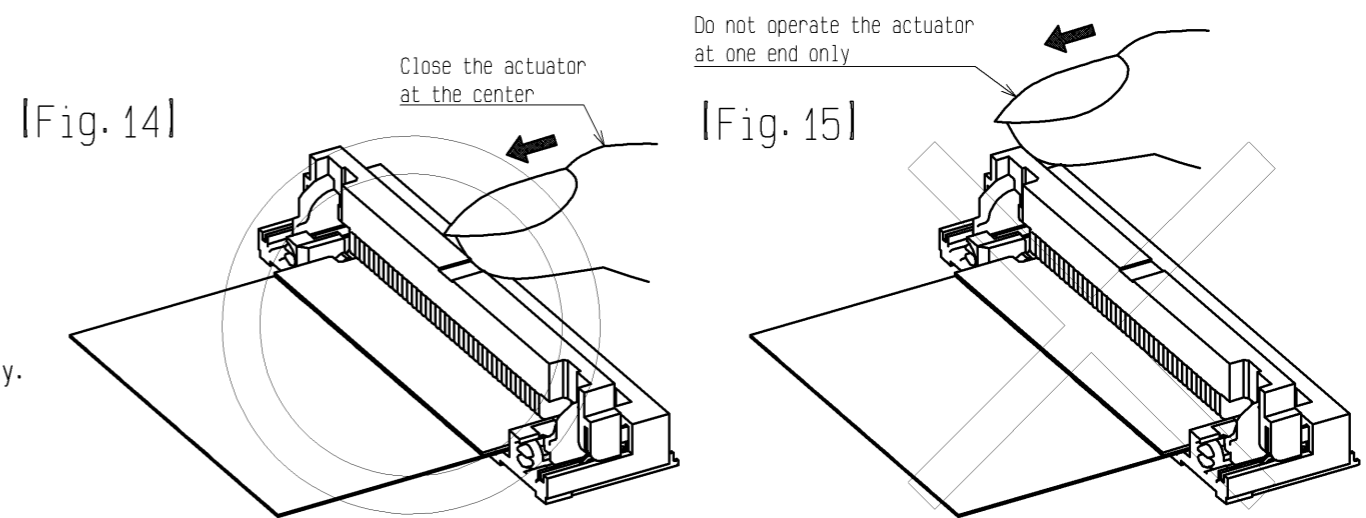
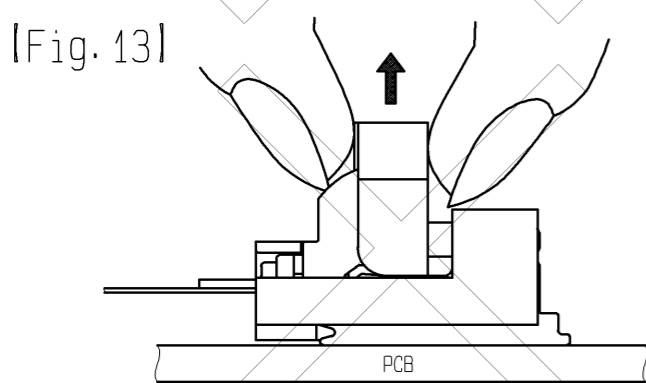
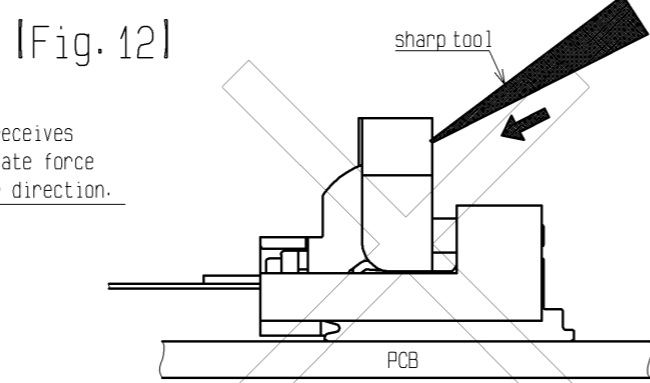
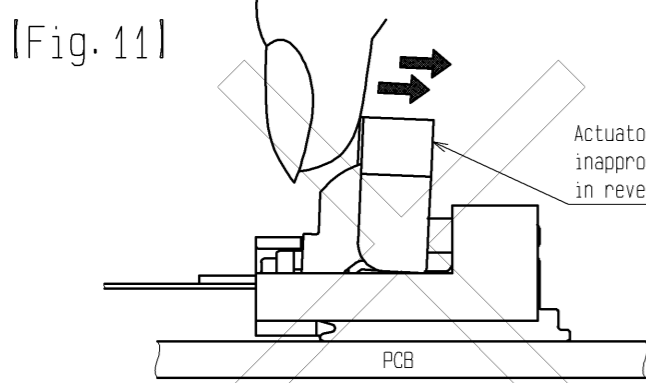
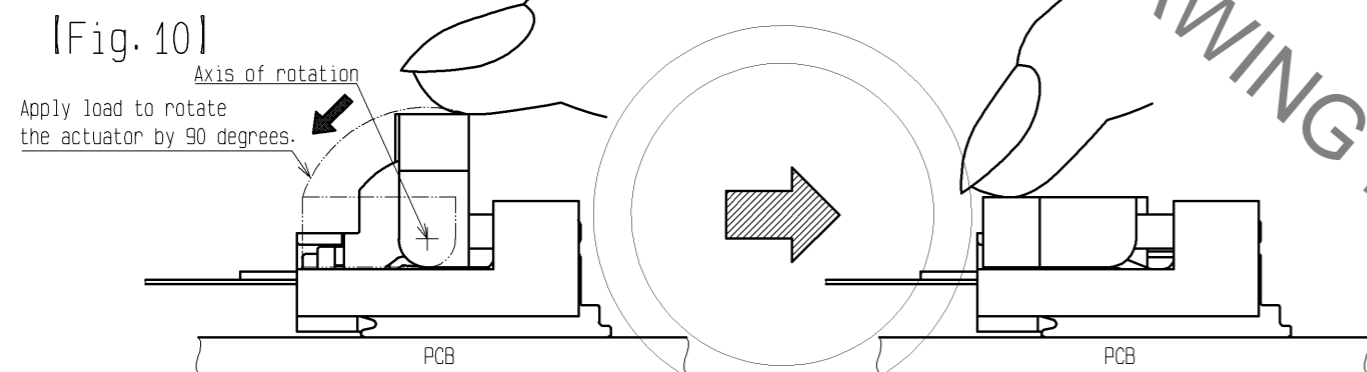

< INSTRUCTION MANUAL (2) >

<b>HRS</b>	DRAWING NO.	EDC3-347196-00
	PART NO.	FH50-40S-0.5SH
	CODE NO.	CL580-4004-2-00
		△ 4/7

Jan.1.2022 Copyright 2022 HIROSE ELECTRIC CO., LTD. All Rights Reserved.  
In case of consideration for using Automotive equipment / device which demand high reliability, kindly contact our sales window correspondents.

3. How to unlock

To release the lock, apply load to rotate the actuator by 90 degrees. [Fig.18]

[Caution]

- ◆ The actuator is opened up to the movable limit, 90 degrees.  
Do not open the actuator beyond the specified degree or apply excess force to the actuator. [Fig.19]
- ◆ Operate the actuator by hand without using sharp tool such as tweezers. [Fig.20]
- ◆ Apply load to the center on the actuator to rotate it.  
Do not apply force to the actuator at one end only.  
Uneven load could twist the actuator and cause actuator breakage. [Fig.21, Fig.22]

[Fig.18]

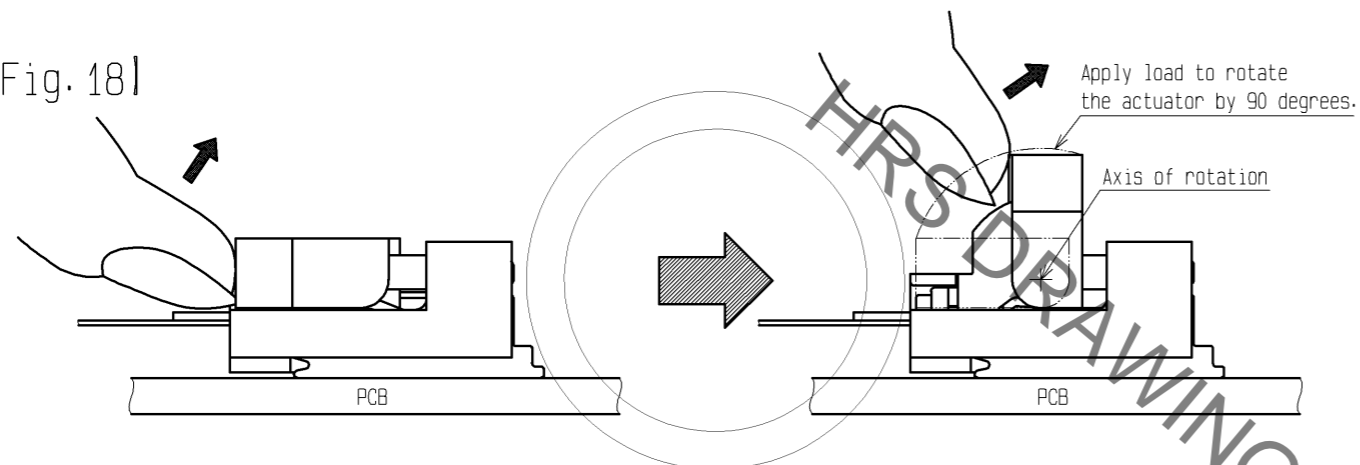

[Fig.19]

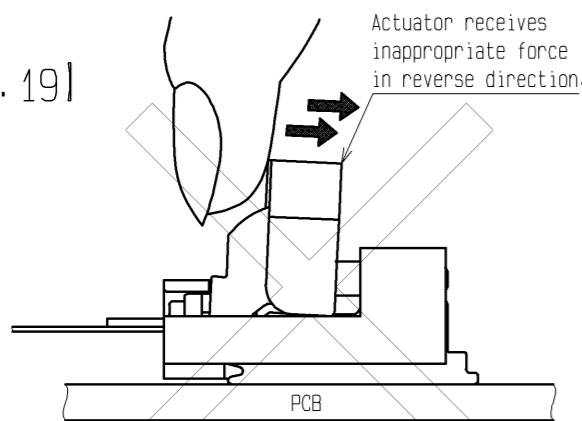

[Fig.20]

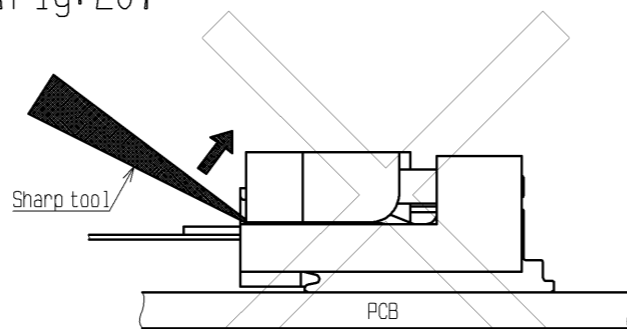

[Fig.21]

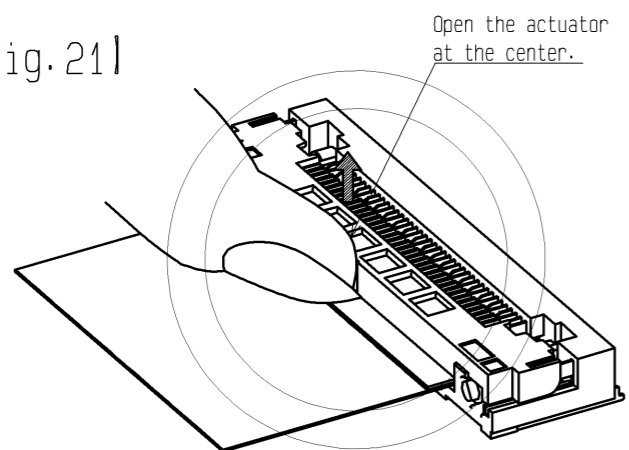

[Fig.22]

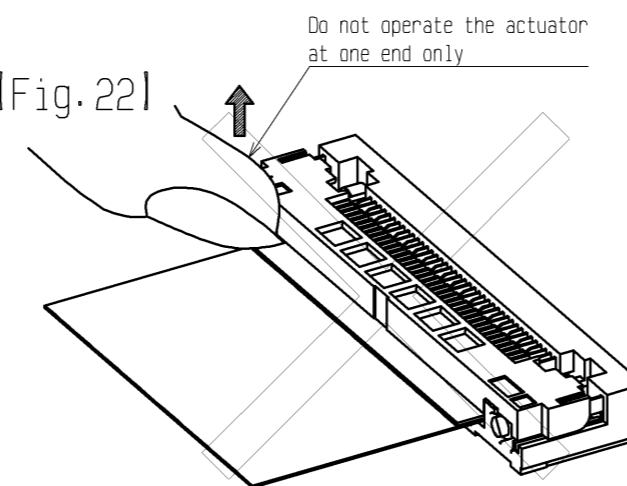

5. How to remove FPC/FFC

After rotating the actuator to the fully opened position, carefully remove the FPC/FFC in the direction parallel to the PCB mounting surface. [Fig.23, Fig.24]

[Caution]

- ◆ Do not remove the FPC/FFC at a sharp angle as this may cause connector breakage or FPC/FFC pattern breakage. [Fig.25, Fig.26]
- ◆ This connector has temporary FPC/FFC holding structure with cams on each sides of the connector. Tactile sensation generated during FPC/FFC removal does not affect connector quality.
- ◆ When the actuator is not fully opened, do not attempt to remove the FPC/FFC as this may cause damage to the connector.  
In that case, stop the operation and confirm if the actuator opens to 90 degrees.  
Then proceed the operation.  
Direction of the slit on cam shows if the FPC/FFC can be removed as shown in ① and ② below.
- ① When the slit on cam is horizontal, the FPC/FFC can be removed. [Fig.27]
- ② If the slit on cam is angled, forcible FPC/FFC removal could cause damage to the connector.  
Confirm if the actuator opens to 90 degrees. [Fig.28]
- ◆ Do not attempt to remove the FPC/FFC without unlocking the actuator.  
This could damage connector and FPC/FFC. [Fig.29]

[Fig.23]

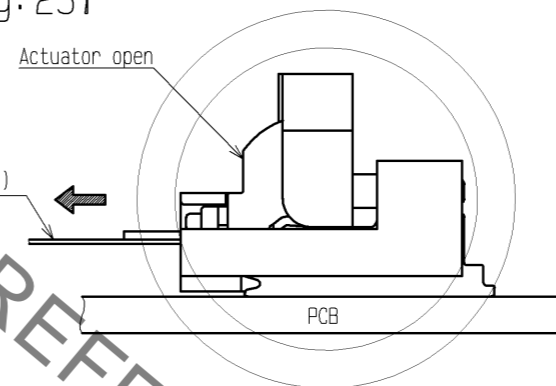

[Fig.24]

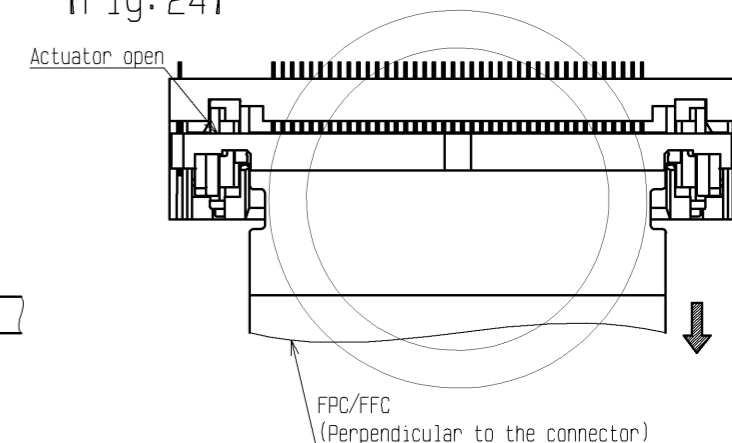

[Fig.25]

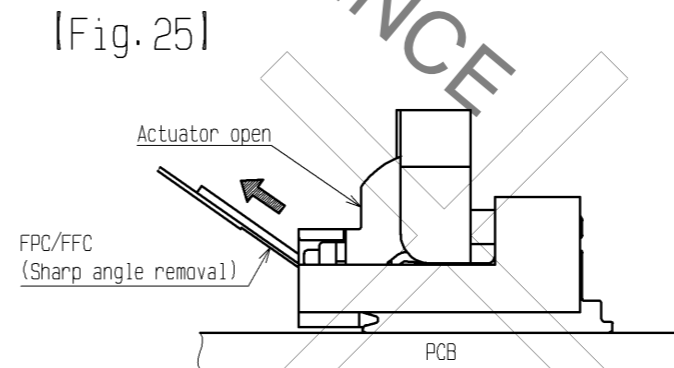

[Fig.26]

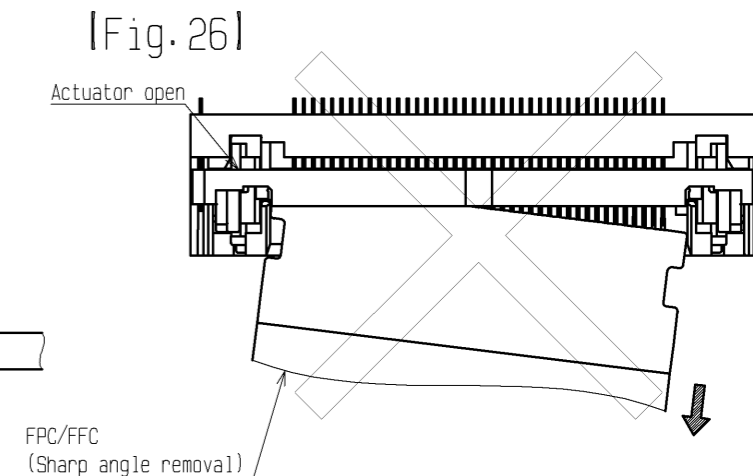

< INSTRUCTION MANUAL (3) >

<b>HRS</b>	DRAWING NO.	EDC3-347196-00
	PART NO.	FH50-40S-0.5SH
	CODE NO.	CL580-4004-2-00
		△ 5/7

Jan.1.2022 Copyright 2022 HIROSE ELECTRIC CO., LTD. All Rights Reserved.  
 In case of consideration for using Automotive equipment / device which demand high reliability, kindly contact our sales window correspondents.

[Fig.27]

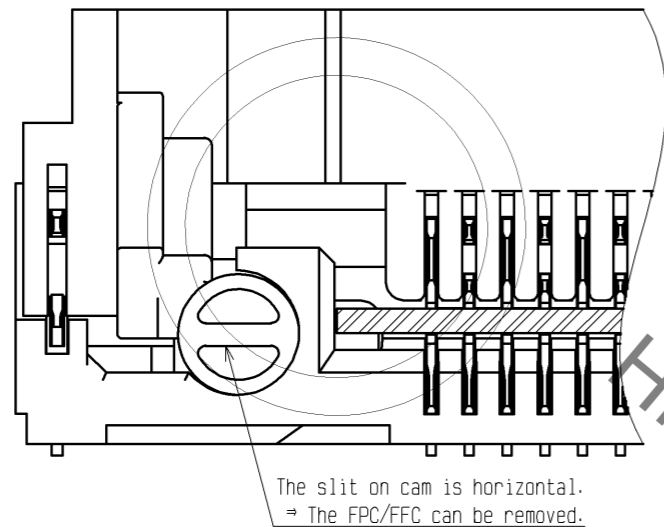

The slit on cam is horizontal.  
 ⇒ The FPC/FFC can be removed.

[Fig.28]

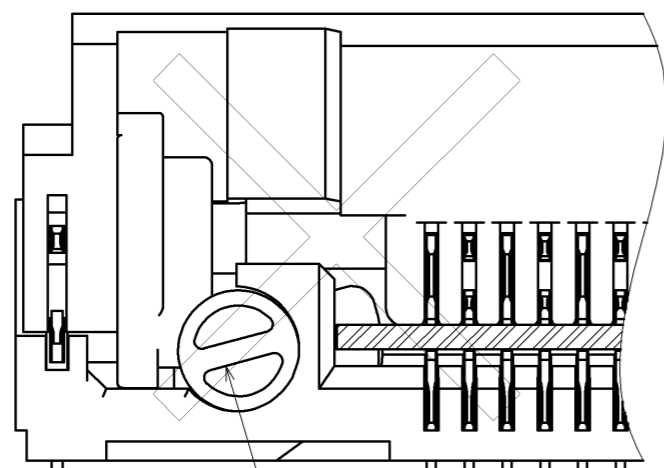

The slit on cam angled.  
 ⇒ Forcible FPC/FFC removal in this condition could cause damage to the connector.  
 Confirm if the actuator opens to 90 degrees.

[Fig.29]

Actuator close

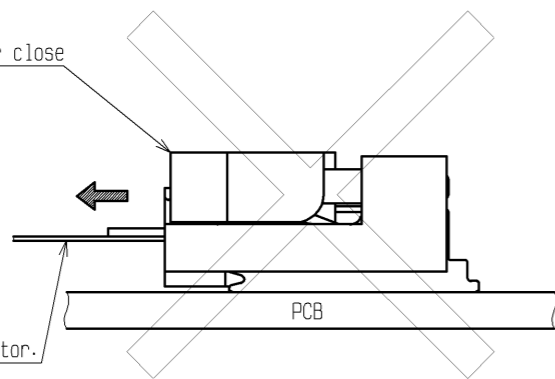

Do not attempt to pull the FPC/FFC without unlocking the actuator.

[Precautions for PCB layout]

Depending on a FPC/FFC wiring, load is applied to the connector, and contact failure (mating failure, FPC/FFC pattern breakage, etc.) may occur.  
 To prevent a failure, take the following notes into a consideration during mechanism design.

[Caution]

- ◆ Avoid applying forces to FPC/FFC in vertical or horizontal directions.  
 In addition, avoid pulling up and down on the FPC/FFC. [Fig.30]
- ◆ During FPC/FFC wiring, avoid pulling FPC/FFC, and route the wire FPC/FFC with slack.  
 In this regard, the stiffener is parallel to the PCB. [Fig.31]
- Do not bend the FPC/FFC excessively near the connector during use, or it may cause contact failure or FPC/FFC breakage. [Fig.32]
- Fixing the FPC/FFC is recommended to prevent these failures.
- ◆ Make sure to provide enough space for FPC/FFC assembly in order to prevent sharp angle insertion.  
 A FPC/FFC that is too short is difficult to assemble.
- ◆ Do not mount other components touching to the FPC/FFC underneath stiffener. [Fig.33]
- ◆ Refer to recommended layout on the page 1 for FPC/FFC design.  
 In addition, please consult FPC/FFC suppliers for the flexibility of bending FPC/FFC.
- ◆ Please design the PCB and component layout to provide enough space for actuator operation.

[Fig.30]

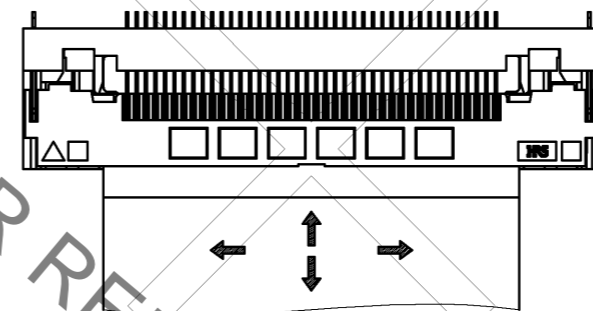

[Fig.31]

Stiffener(Parallel to the PCB)

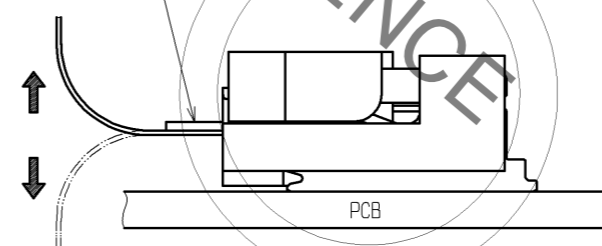

[Fig.32]

Stiffener(Angled)

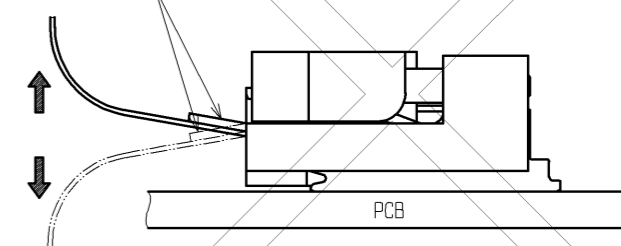

[Fig.33]

Stiffener(Angled)

Component part

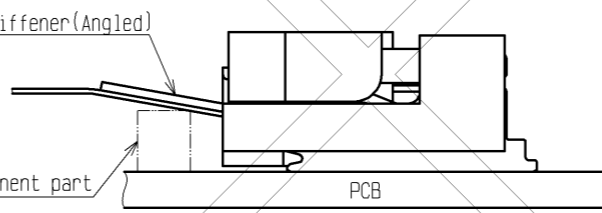

< INSTRUCTION MANUAL (4) >

**HRS**

DRAWING NO.	EDC3-347196-00
PART NO.	FH50-40S-0.5SH
CODE NO.	CL580-4004-2-00

△ 6/7

Jan.1.2022 Copyright 2022 HIROSE ELECTRIC CO., LTD. All Rights Reserved.  
In case of consideration for using Automotive equipment / device which demand high reliability, kindly contact our sales window correspondents.

[Instructions for mounting on the PCB]

Follow the instructions shown below when mounting on the PCB.

[Caution]

- ◆ Refer to recommended layouts on the page 1 for PCB and stencil design.
- ◆ Prevent warpage of PCB, where possible, since it can cause soldering failure even with 0.1mm max coplanarity.
- ◆ A stiffener must be provided on mounted side of FPC for easy handling. Confirmation is required prior to mass production.
- ◆ When unreeled or pick and place the connector, do not apply any external force to the connector over 1N to prevent connector damage.
- ◆ Apply reflow temperature profile within the specified conditions. In individual applications, the actual temperature may vary, depending on solder paste type, volume/thickness and PCB size/thickness. Confirmation is required prior to mass production.

[Instructions for PCB handling after mounting the connector]

Follow the instructions shown below when handling the PCB after mounting the connector.

[Caution]

- ◆ Split PCBs with multiple piece production. Screw down PCB etc. Do not apply any force to the connectors during the process, or connectors could be damaged.
- ◆ The bend of a 100mm wide PCB should be 1 mm or less. Excessive bending of PCB may cause malfunction or damage to the connector. [Fig.34]

[Fig. 34]

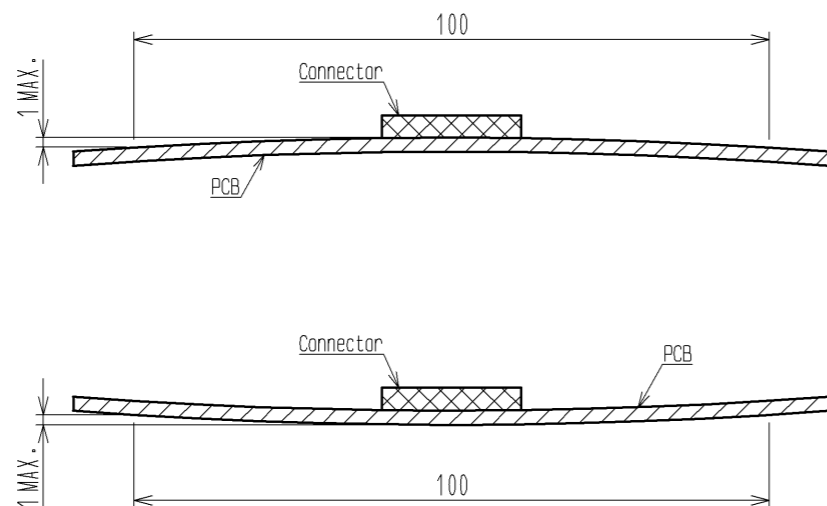

[Instructions for manual soldering]

Follow the instructions shown below for manual soldering such as repair work.

[Caution]

- ◆ Do not perform soldering operations with the FPC/FFC inserted in the connector.
- ◆ The soldering iron must contact only the terminals. Do not touch any other part of the connector with the soldering iron.
- ◆ Do not apply excessive solder (or flux). If excessive solder (or flux) is applied on the terminals, solder or flux may adhere to the contacts or rotating parts of the actuator, resulting in the poor contact or rotation failure of the actuator. Do not use excessive solder on the metal fittings as this may interfere with the actuator rotation and cause connector damage.

HRS DRAWING FOR REFERENCE

< INSTRUCTION MANUAL (5) >

<b>HRS</b>	DRAWING NO.	EDC3-347196-00
	PART NO.	FH50-40S-0.5SH
	CODE NO.	CL580-4004-2-00



## X-ON Electronics

Largest Supplier of Electrical and Electronic Components

*Click to view similar products for [FFC & FPC Connectors](#) category:*

*Click to view products by [Hirose](#) manufacturer:*

Other Similar products are found below :

[K-FC20](#) [FH29B-80S-0.2SHW\(99\)](#) [FPH-2022G](#) [AYF332735](#) [52610-1075](#) [52610-1275](#) [52610-1934](#) [501864-3091-TR225](#) [086222026001800](#)  
[52610-0675](#) [62684-36210E9ALF](#) [52746-1671-TR250](#) [10051922-2810EHLF](#) [6-520415-9](#) [SFV6R-1STE9HLF](#) [XF3M-2915-1B-R100](#)  
[1658549-1](#) [46214008010800](#) [AYF534065TA](#) [AYF351525](#) [086212040340800+](#) [AYF530365TA](#) [67000-014LF](#) [67000-004LF](#)  
[006207341915000+](#) [DS1020-19RT1D](#) [67000-003LF](#) [67000-011LF](#) [67000-016LF](#) [HFW14R-2STE9LF](#) [SFV32R-2STBE9HLF](#) [SFW12R-](#)  
[5STE9LF](#) [SFW18R-1STAE9LF](#) [SFW4R-5STE9LF](#) [52807-0430](#) [046283021002868+](#) [THD1015-8CL-SN](#) [67000-006LF](#) [502250-8027](#)  
[104267-9617](#) [66987-011LF](#) [AYF362535](#) [F0501-T-50-20T-R](#) [HFW8S-2STAE1HLF](#) [67000-008LF](#) [67000-012LF](#) [ECC576069EU](#) [F1002-B-](#)  
[20-20T-R](#) [HFW15S-2STAE1HLF](#) [0781271110](#)