

# 1mm Pitch Wire-to-Board Connectors supporting LVDS signal

## FX15 Series

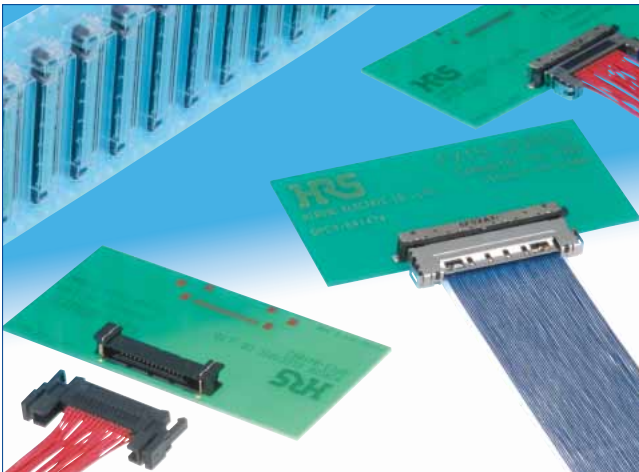

### Space saving, Equal length transmission lines

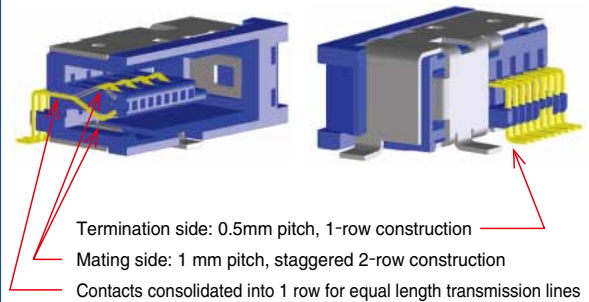

Fig.1

## Features

### 1. Space-saving

Reduction in space is achieved by designing the contacts in 2-row staggered 1mm pitch on the mating side and on a single row 0.5mm pitch on the termination side (Fig.1).

### 2. Equal length transmission lines

Contact configuration provides equal length transmission lines, which prevents LVDS signal loss within the connector.

### 3. Variations

Availability of shielded and non-shielded types allows for design flexibility and cost reduction.

### 4. Self alignment and self-guiding

Built-in guide posts allow secure self-alignment within  $\pm 1.5\text{mm}$  (Fig.2).

### 5. Secure and complete mating / unmating

Side latch locking provides complete and secure mating, as well as easy unmating (Fig.3).

### 6. Enhanced shielding performance with FX15S

Enlarged metal shields prevent intrusion and emission of electromagnetic interference, which enhances the integrity of the LVDS signal (Fig.4).

### 7. RoHS compliant

All materials and substances used to produce this product comply with RoHS standards.

### Self-alignment of $\pm 1.5\text{mm}$

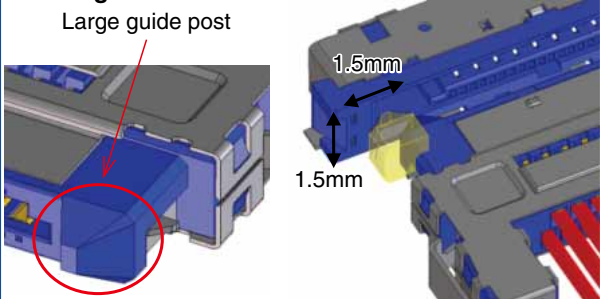

Fig.2

### Side latch -locks

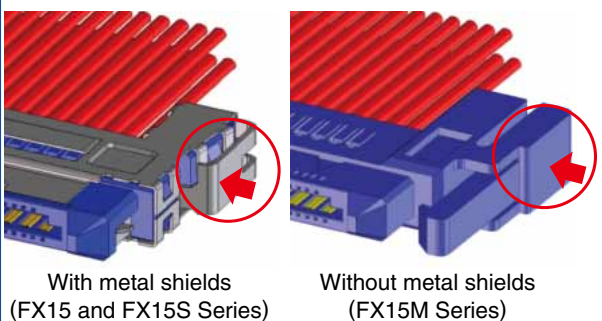

Fig.3

### High Shielding Performance

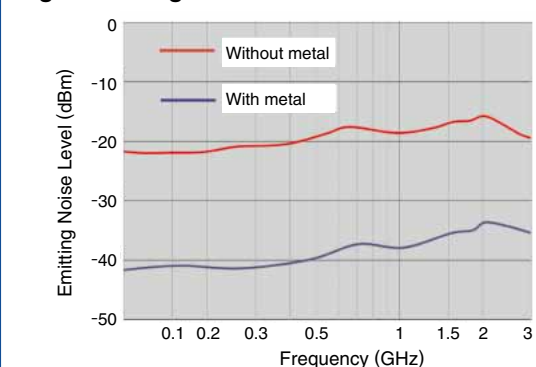

Fig.4

## Product Specifications

Ratings	Current rating Voltage rating	0.5A 100V AC	Operating temperature range Storage temperature range	-55°C to +80°C (Note 1) -10°C to +60°C (Note 2)
Item	Specification	Conditions		
1. Contact resistance	60mΩ max. (Note 3)	1mA		
2. Insulation resistance	500MΩ min.	100V DC		
3. Withstanding voltage	No flashover or insulation breakdown.	300V AC/one minute		
4. Insertion-Extraction force	2N min., 30N max.	With corresponding connector		
5. Mating cycles	Contact resistance : 80mΩ max.(Note 3)	50 cycles		
6. Vibration resistance	No electrical discontinuity of 1μs or more.	Frequency: 10 to 55 Hz, single amplitude of 0.75mm, 2 hours, 3 axis		
7. Shock resistance	No electrical discontinuity of 1μs or more.	Acceleration of 490m/s <sup>2</sup> , 11ms durations, sine half-wave waveform, 3 cycles, 3axis.		
8. Humidity resistance	Contact resistance : 80mΩ max. No damage, cracks, or parts dislocation.(Note 3)	96 hours at 40°C, RH 90% to 95%		
9. Temperature cycle	Contact resistance : 80mΩ max. (Note 3) Insulation resistance : 500MΩ min.	Temperature : -55°C → +15°C to +35°C → +85°C → +15°C to +35°C Time : 30 → 5 → 30 → 5 (Minutes) 5 cycles		
10. Salt spray	Contact resistance : 80mΩ max. (Note 3) No corrosions	5% water solution for 48 hours.		

Note 1 : Includes temperature rise caused by current flow.

Note 2 : The term “storage” refers to products stored for long period of time prior to mounting and use. Operating temperature and humidity range includes non-conducting condition of installed connectors in storage, shipment or during transportation.

Note 3 : Includes wire conductor resistance (12mm long).

## Materials / Finish

### ● Receptacle

Component	Material	Finish	Remarks
Insulator	Polyamide	Color : Black	UL94V-0
Contact	Phosphor bronze	Contact area : Gold plated Termination area : Tin plated	_____
Metal shell (shielded version only)	FX15S : Nickel silver FX15SC : Stainless steel	FX15S : _____ FX15SC : Tin plated	_____
Metal fittings (shielded version only)	Phosphor bronze	Selective gold flash plated	_____

### ● Plug

Component	Material	Finish	Remarks
Insulator	Polyamide	Color : Black	UL94V-0
Contact	Phosphor bronze	Contact area : Gold plated Termination area : Tin plated	_____
Metal shell (shielded version only)	Nickel silver	_____	_____
Metal latch locks (shielded version only)	Stainless steel	_____	_____
Metal shell, metal latch locks (on micro coax version only)	Stainless steel	Nickel plated	_____

## Product Number Structure

### ● Receptacle

**FX15 S - 31 S - 0.5 SH (\*\*)**

① ② ③ ④ ⑤ ⑥ ⑪

### ● Plug

**FX15 S - 31 P - C**

① ② ③ ④ ⑦

### ● Crimp contact

**FX15 - 3032 PCF B**

① ⑧ ⑨ ⑩

① Series Name	: FX15
② Configuration	Blank : With shields (or crimp contact) 15S : With shields – enhanced shielding 15SC : With shields – enhanced shielding (PCB mounting pattern : VESA standard) 15M : Without shields
③ Number of contacts	
④ Connector type	P : Male contact S : Female contact
⑤ Contact pitch	: 0.5 mm
⑥ Housing configuration	SH : Right angle SV : Straight
⑦ Termination	C : Crimp 0.5SD : Micro-coaxial cable GND : Separate ground plate
⑧ Applicable conductor	2830 : 28 to 30 AWG 3032 : 30 to 32 AWG
⑨ Packaging	PCF : Male contact / reel
⑩ Plating (contact area)	B : Gold plated
⑪ Packaging	Blank : Embossed Packaging (1,000 pcs/reel) (30) : Embossed Packaging (100 pcs/reel)

# FX15 Series – Functional Diagram

## Crimp contact

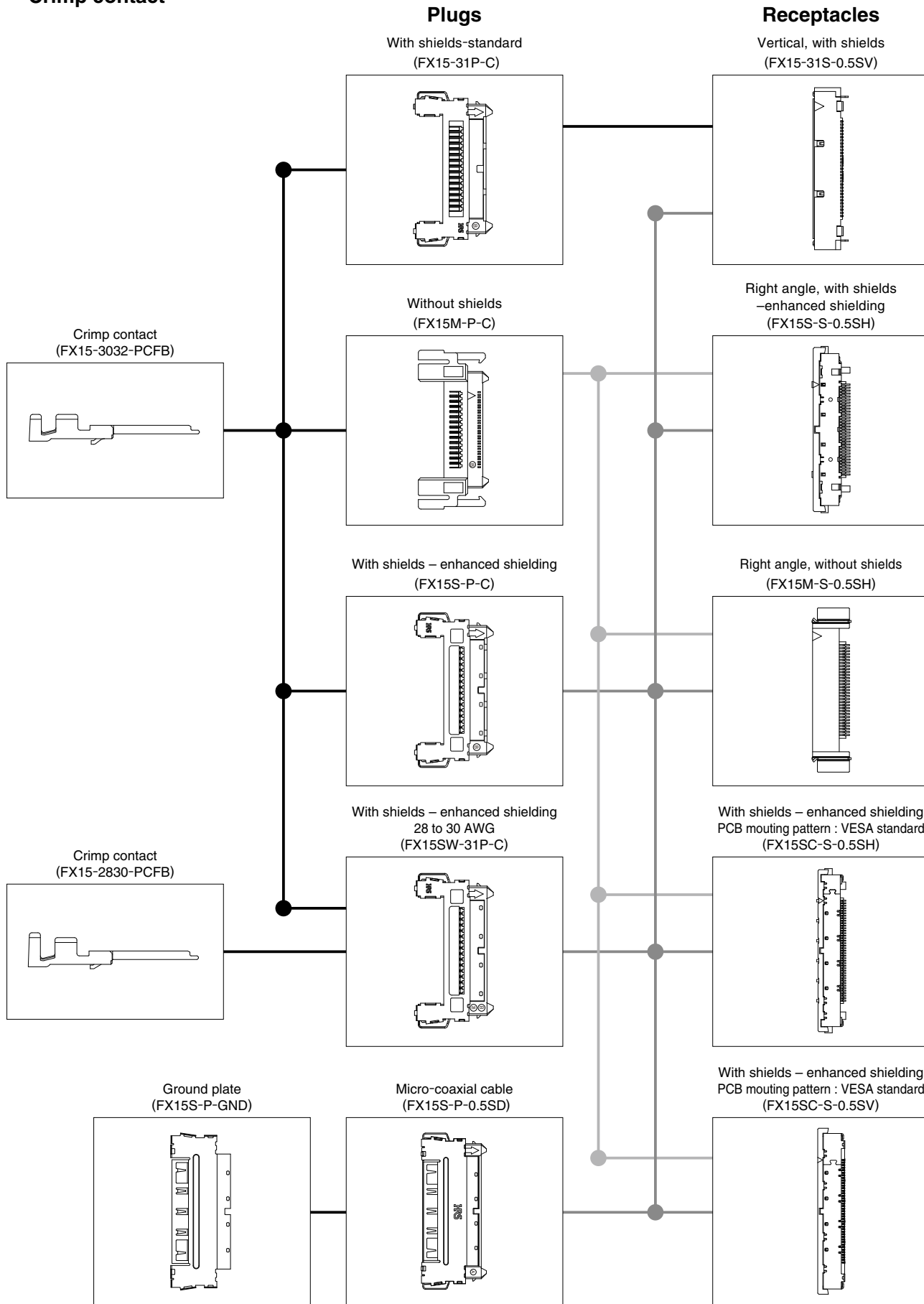

Dec.1.2021 Copyright 2021 HIROSE ELECTRIC CO., LTD. All Rights Reserved.

## Plugs

### ● With shields (FX15-31P-C)

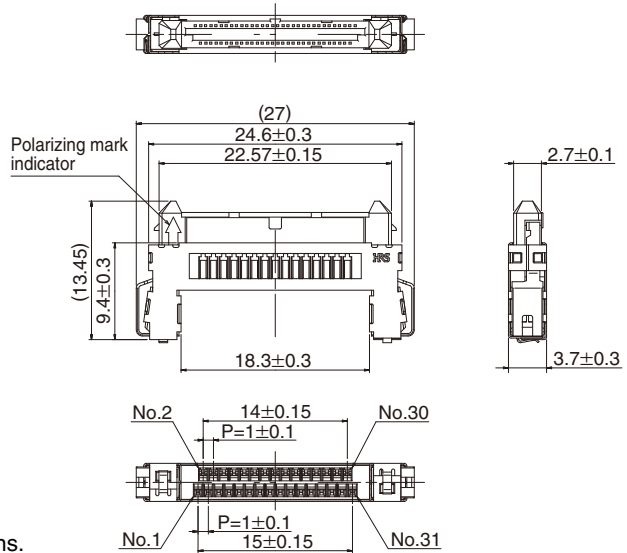
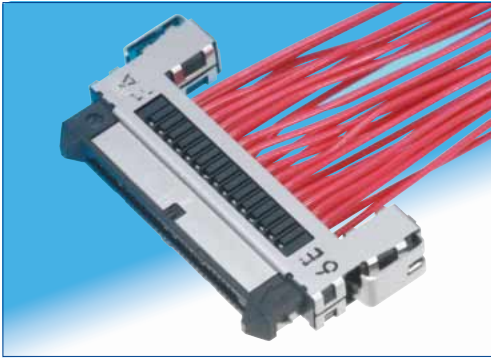

Part No.	HRS No.	No. of contacts	RoHS
FX15-31P-C	575-2101-2	31	Yes

Note 1 : Packaged in trays.

Note 2 : Dimensions in parenthesis ( ) are reference dimensions.

### ● With shields, enhanced shielding (FX15S-\*\*\*P-C)

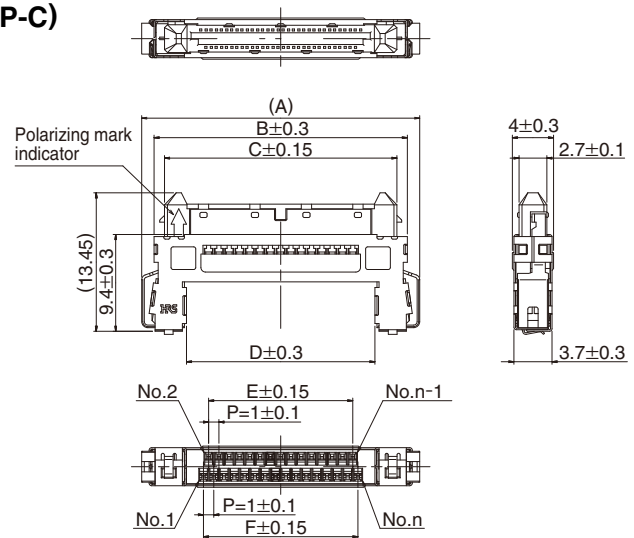
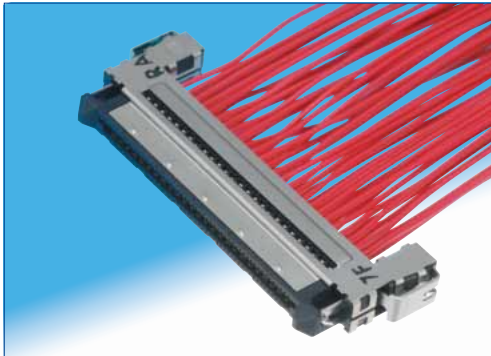

Part No.	HRS No.	No. of contacts	A	B	C	D	E	F	RoHS
FX15S-31P-C	575-2106-6	31	27	24.6	22.6	18.3	14	15	Yes
FX15S-41P-C	575-2107-9	41	32	29.6	27.6	23.3	19	20	
FX15S-51P-C	575-2103-8	51	37	34.6	32.6	28.3	24	25	

Note 1 : Packaged in trays.

Note 2 : Dimensions in parenthesis ( ) are reference dimensions.

●With shields – enhanced shielding  
28 to 30 AWG (FX15SW-31P-C)

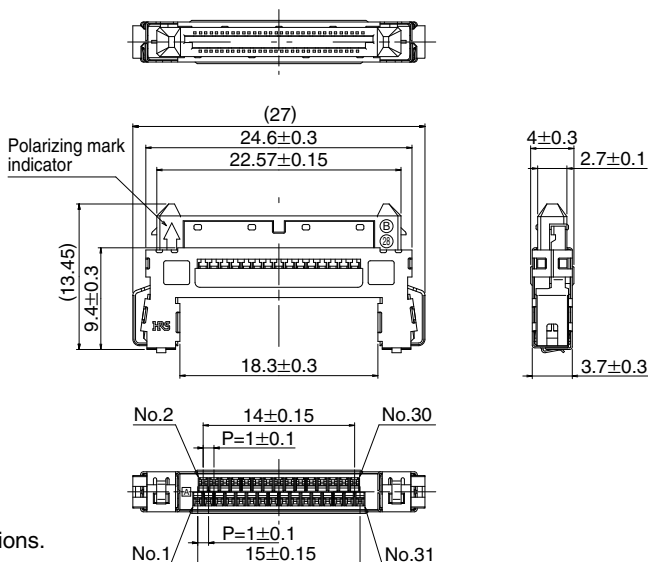
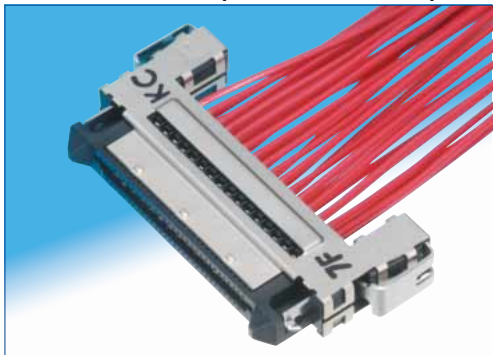

Part No.	HRS No.	No. of contacts	RoHS
FX15SW-31P-C	575-2113-1	31	Yes

Note 1 : Packaged in trays.

Note 2 : Dimensions in parenthesis ( ) are reference dimensions.

●Without shields (FX15M-\*\*P-C)

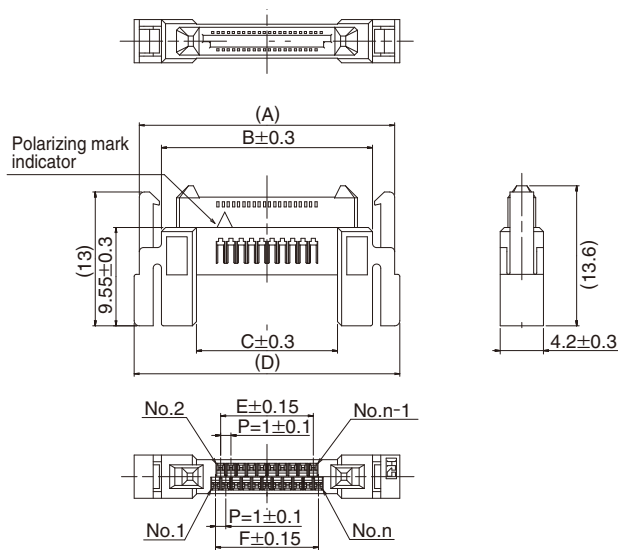
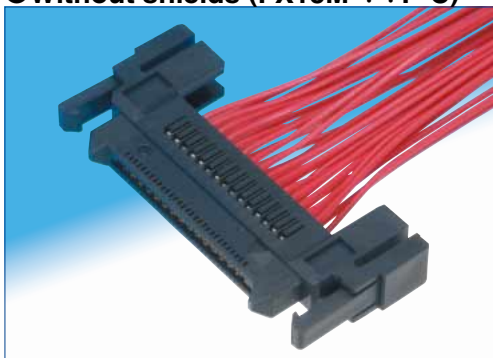

Part No.	HRS No.	No. of contacts	A	B	C	D	E	F	RoHS
FX15M-21P-C	575-2109-4	21	24.8	20.5	13.7	25.8	9	10	Yes
FX15M-31P-C	575-2108-1	31	29.8	25.5	18.7	30.8	14	15	

Note 1 : Sold in 100 piece packages. Please order in full package quantities.

Note 2 : Dimensions in parenthesis ( ) are reference dimensions.

### ◆ Plug crimp contacts

Part No.	HRS No.	Packaging	Quantity	Finish	RoHS
FX15-2830PCFB	575-2002-0	Reel	20,000 pcs/reel	Gold plated	Yes
FX15-3032PCFB	575-2003-3				

### ● Applicable cable (Tin plated, annealed copper wire)

FX15-2830PCFB

Applicable wire size (Stranded wire conductor)	Jacket diameter	UL No.
28 AWG (7/0.127mm)	φ0.56 to 0.72mm	1517
30 AWG (7/0.1mm)		1571

FX15-3032PCFB

Applicable wire size (Stranded wire conductor)	Jacket diameter	UL No.
30 AWG (7/0.1mm)	φ0.5 to 0.6mm	1516, 1571 (Note)
32 AWG (7/0.08mm)		1571

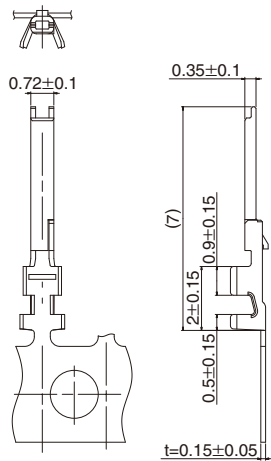

### ● Wire strip length: 1.1 to 1.8mm

Note : When using wires other than those noted above, please contact Hirose for assistance.

### ● Tools

Item	Part No.	HRS No.	Applicable crimp contact
Applicator	AP105-FX15-2830	901-4036-0	FX15-2830PCFB
	AP105-FX15-3032	901-4033-1	FX15-3032PCFB
Press unit	CM-105C	901-0001-0	—

Dec.1.2021 Copyright 2021 HIROSE ELECTRIC CO., LTD. All Rights Reserved.

● Plug – Micro-coaxial cable (FX15S-\*\*P-0.5SD)

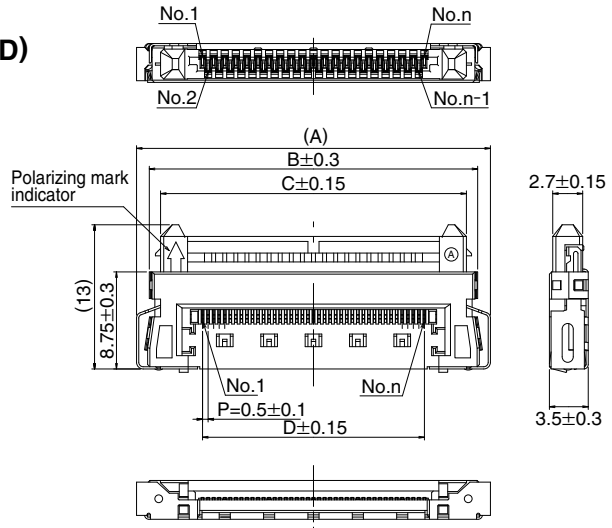
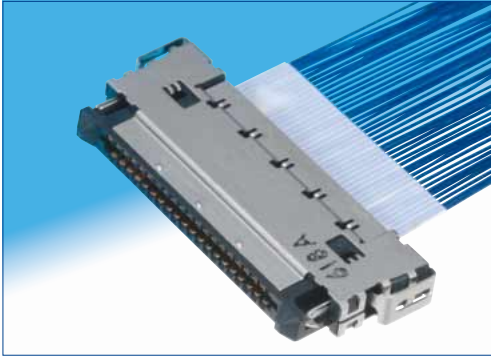

Part No.	HRS No.	No. of contacts	A	B	C	D	RoHS
FX15S-41P-0.5SD	575-2110-3	41	31.9	29.6	27.57	20	Yes
FX15S-51P-0.5SD	575-2118-5	51	36.9	34.6	32.57	25	

Note 1 : Packaged in trays.

Note 2 : Dimensions in parenthesis ( ) are reference dimensions.

● Ground plate for micro-coaxial cable type

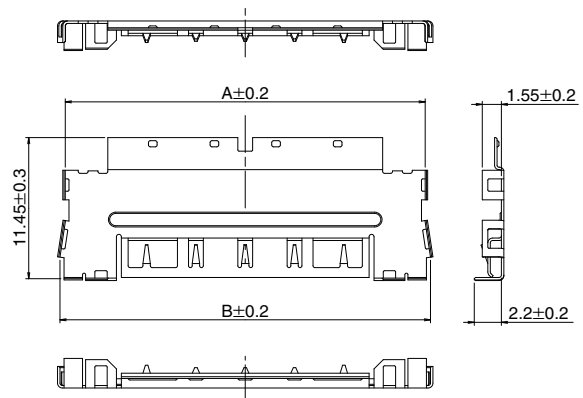
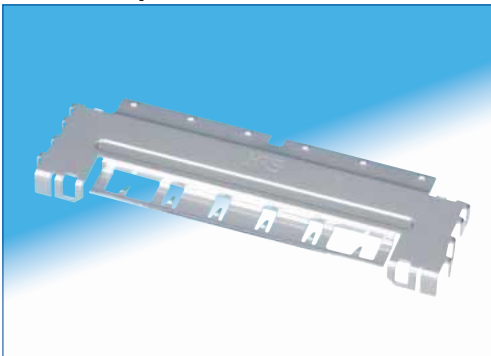

Part No.	HRS No.	No. of contacts	A	B	RoHS
FX15S-41P-GND	575-2111-6	41	29.2	30.06	Yes
FX15S-51P-GND	575-2117-2	51	34.2	35.06	

Note 1 : Packaged in trays.

Note 2 : Dimensions in parenthesis ( ) are reference dimensions.

● Applicable cable (Micro-coaxial cable)

Wire size (Standed wire inner conductor)	Jacket diameter
36 AWG (7/0.05mm)	0.3mm to 0.5mm
38 AWG (7/0.04mm)	
40 AWG (7/0.03mm)	

No. of contacts	A	B
41	23.1	20
51	28.1	25

● Cable preparation

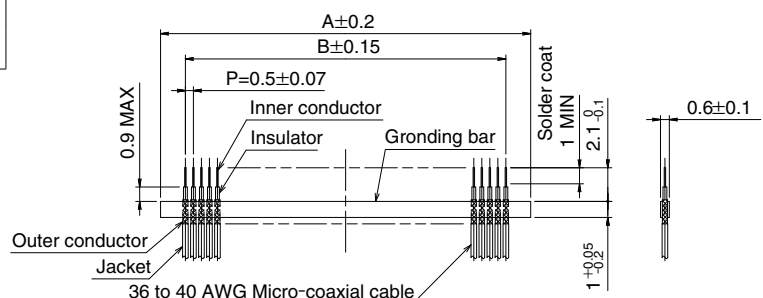

## ■ Receptacles

### ● Vertical, with shielding (FX15-31S-0.5SV)

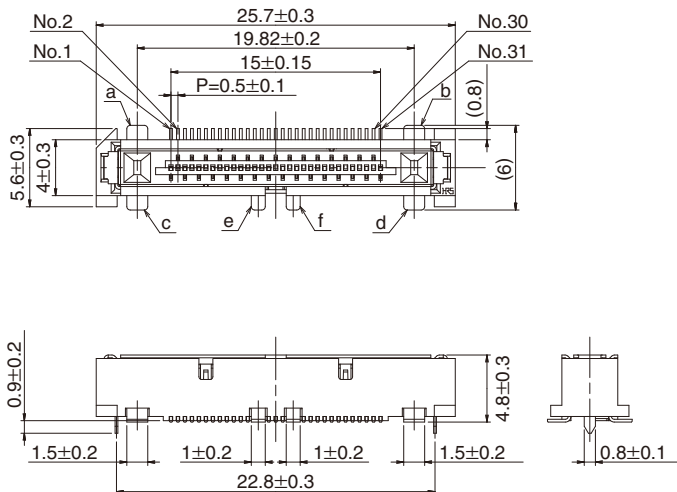

Part No.	HRS No.	No. of contacts	RoHS
FX15-31S-0.5SV(**)	575-2201-7 **	31	Yes

**[Specification Number : \*\*, (\*\*)]**  
 Blank : Embossed packaging (1,000 pcs/reel)  
 (30) : Embossed packaging (100 pcs/reel)

## ◆ Recommended PCB mounting pattern and metal mask dimensions

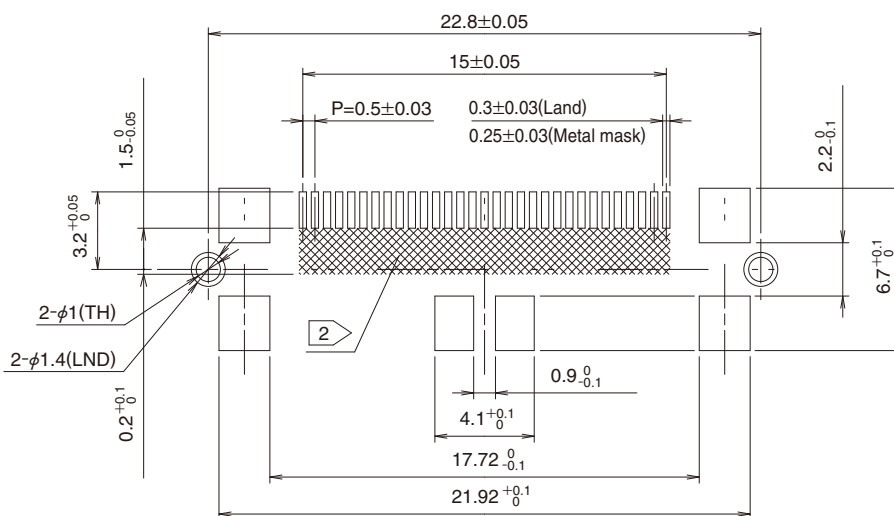

Note 1 : The co-planarity of the terminal leads is as follows:

- All signals and shield leads "c" and "d": 0.1mm max.
- Shield leads "a", "b", "e" and "f": 0.15mm max.

② : Area indicated by the crosshatched lines must be free of conductive traces or the conductive traces must be covered by resist film.

3 : Packaged on tape-and-reel.

4 : Dimensions in parenthesis ( ) are reference dimensions.



●Right angle with shields – enhanced shielding (FX15S-\*\*-S-0.5SH)

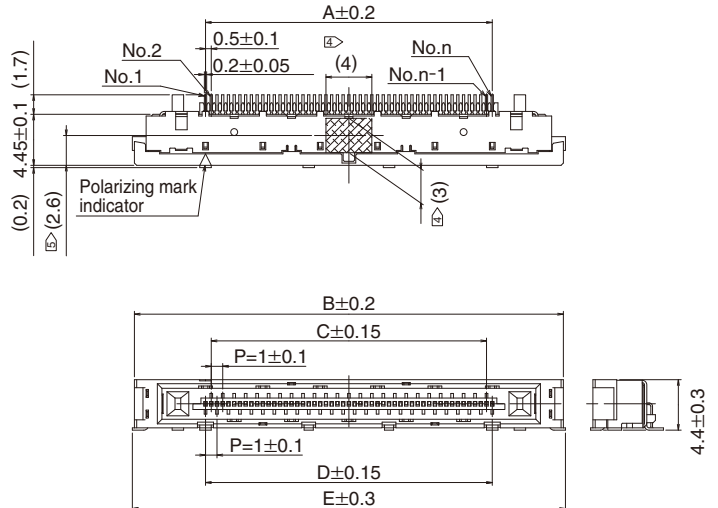
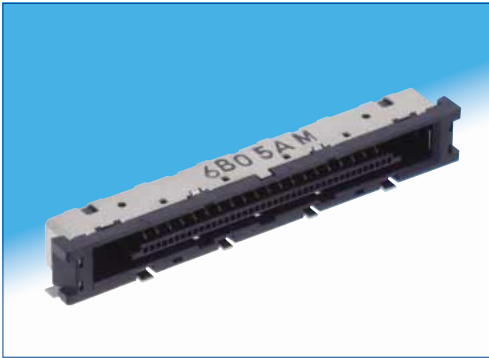

Part No.	HRS No.	No. of contacts	A	B	C	D	E	F	G	H
FX15S-31S-0.5SH(**)	575-2306-5 **	31	15	27.4	14	15	27.8	28.8	24.8	21.6
FX15S-41S-0.5SH(**)	575-2307-8 **	41	20	32.4	19	20	32.8	33.8	29.8	26.6
FX15S-51S-0.5SH(**)	575-2303-7 **	51	25	37.4	24	25	37.8	38.8	34.8	31.6

J	K	L	M	N	P	R	S	RoHS
18	15	—	—	13.2	16.8	24.8	40	Yes
23	20	5.2	8.8	18.2	21.8	29.8	45	
28	25			23.2	26.8	34.8	50	

◆Recommended PCB mounting pattern and metal mask dimensions

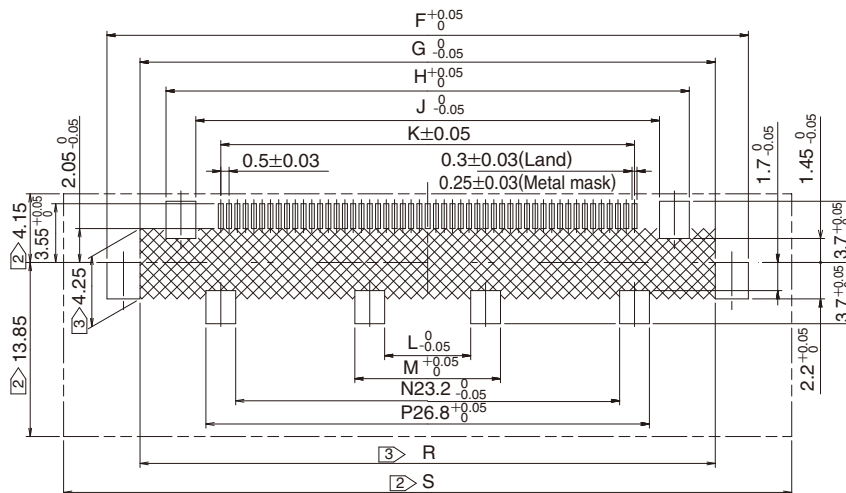

Note 1 : The coplanarity of the terminal leads is 0.1mm max. for all signal leads and 0.15mm max. for the shield leads.

- ② : Do not place any components in the area indicated. Placement of components in this area may affect mating and latch lock operation.
- ③ : Area indicated by the cross-hatched lines must be free of conductive traces or the conductive traces must be covered by resist film.
- ④ : The area marked indicates vacuum pick-and-place area for board placement with automatic equipment.
- ⑤ : Vacuum pick-up area
- 6 : Packaged on tape-and-reel.
- 7 : Dimensions in parenthesis ( ) are reference dimensions.

● Right angle, without shielding (FX15M-\*\*-\*\*S-0.5SH)

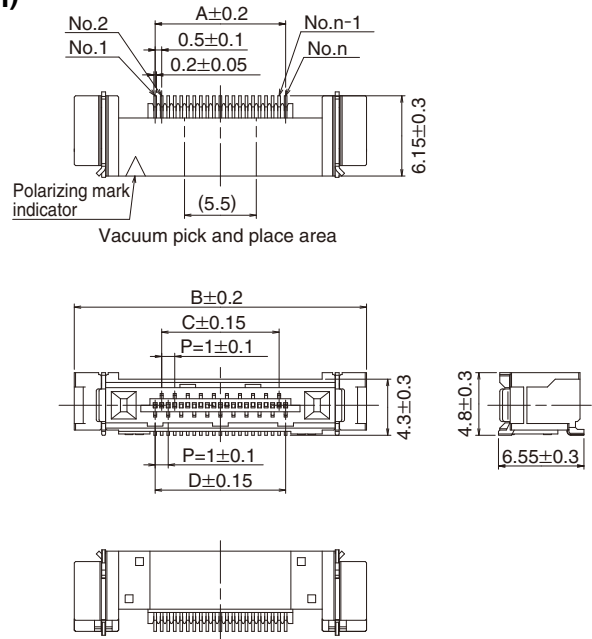
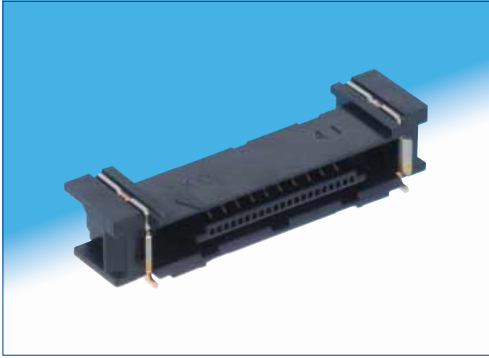

**[Specification Number : \*\*, (\*\*) ]**  
 Blank : Embossed packaging (1,000 pcs/reel)  
 (30) : Embossed packaging (100 pcs/reel)

Part No.	HRS No.	No. of contacts	A	B	C	D	E	F	G	RoHS
FX15M-21S-0.5SH(**)	575-2309-3 **	21	10	22.4	9	10	17.9	10	35	Yes
FX15M-31S-0.5SH(**)	575-2308-0 **	31	15	27.4	14	15	22.9	15	40	

◆ Recommended PCB mounting pattern and metal mask dimensions

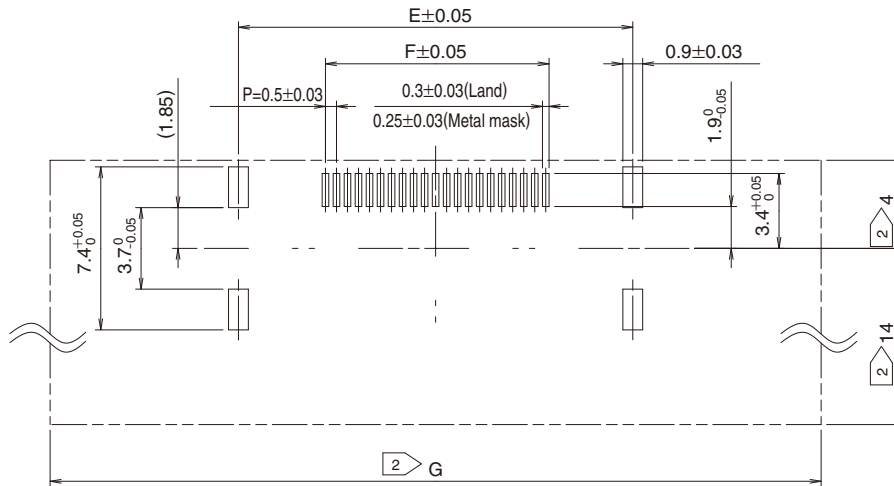

Note 1 : The co-planarity of all terminal leads is 0.1mm max.

② : Do not place any components in the area indicated. Placement of components in this area may affect mating and latch lock operation.

③ : Packaged on tape-and-reel.

●Right angle with shields – enhanced shielding (FX15SC-\*\*-\*\*S-0.5SH)  
PCB mounting pattern : VESA standard

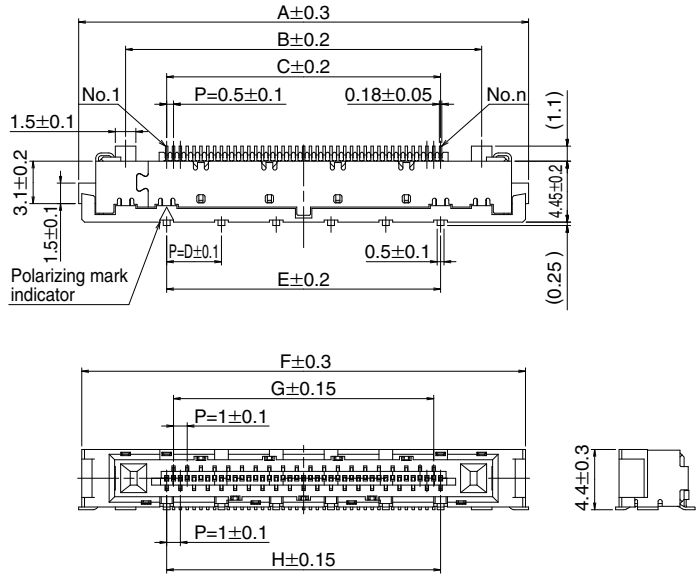
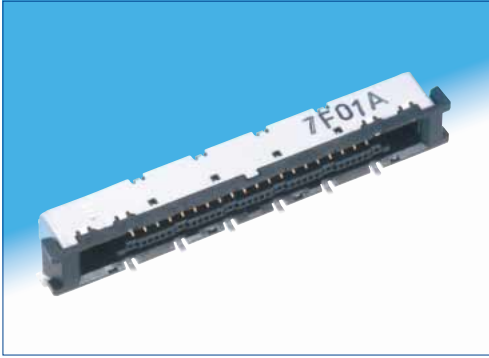

**[Specification Number : \*\*, (\*\*) ]**  
Blank : Embossed packaging (1,000 pcs/reel)  
(30) : Embossed packaging (100 pcs/reel)

Part No.	HRS No.	No. of contacts	A	B	C	D	E	F	G	H	J	K	RoHS
FX15SC-41S-0.5SH(**)	575-2310-2 **	41	32.85	26	20	4	20	32.4	19	20	29.75	45	Yes
FX15SC-51S-0.5SH(**)	575-2311-5 **	51	37.85	31	25	5	25	37.4	24	25	34.75	50	

◆Recommended PCB mounting pattern and metal mask dimensions

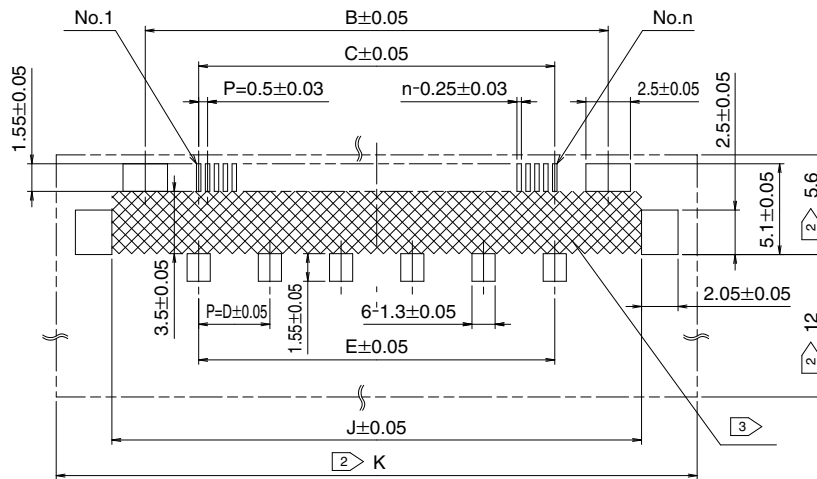

Note 1 : The coplanarity of the terminal leads is 0.1mm max.

② : Do not place any components in the area indicated. Placement of components in this area may affect mating and latch lock operation.

③ : Area indicated by the cross-hatched lines must be free of conductive traces or the conductive traces must be covered by resist film.

4 : Packaged on tape-and-reel.

5 : Dimensions in parenthesis ( ) are reference dimensions.

● Vertical with shields – enhanced shielding (FX15SC-\*\*-S-0.5SV)  
PCB mounting pattern : VESA standard

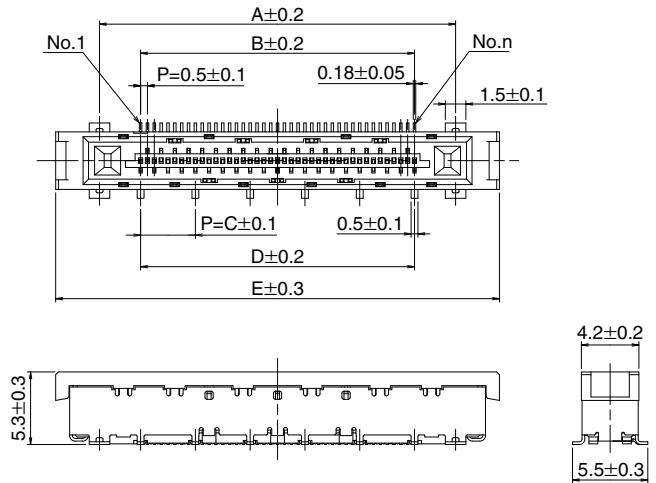
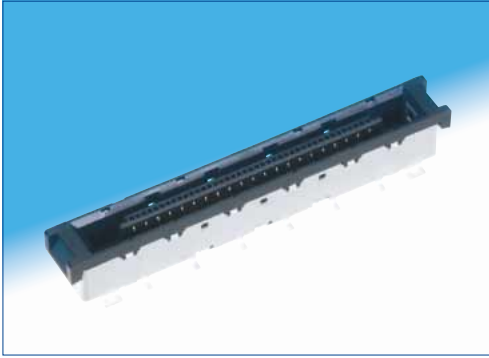

[Specification Number : \*\*, (\*\*) ]  
Blank : Embossed packaging (1,000 pcs/reel)  
(30) : Embossed packaging (100 pcs/reel)

Part No.	HRS No.	No. of contacts	A	B	C	D	E	RoHS
FX15SC-41S-0.5SV(**)	575-2205-8 **	41	26	20	4	20	32.4	Yes
FX15SC-51S-0.5SV(**)	575-2204-5 **	51	31	25	5	25	37.4	

◆ Recommended PCB layout and metal mask dimensions

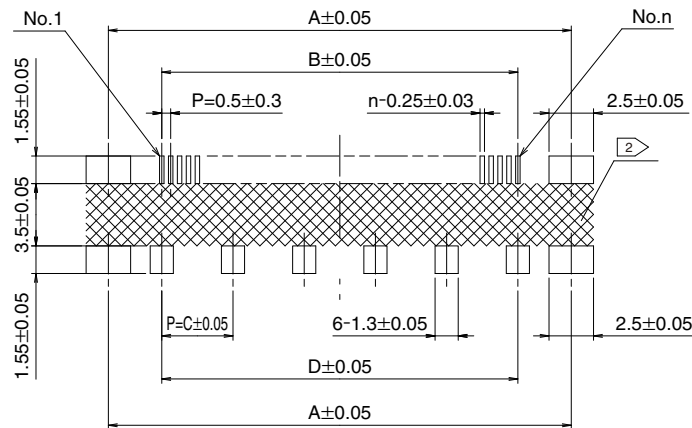

Note 1 : The coplanarity of the terminal leads is 0.1mm max.

② : Area indicated by the cross-hatched lines must be free of conductive traces or the conductive traces must be covered by resist film.

3 : Packaged on tape-and-reel.

## ◆ Packaging Specifications

### ● Vertical, with shields (FX15-31S-0.5SV)

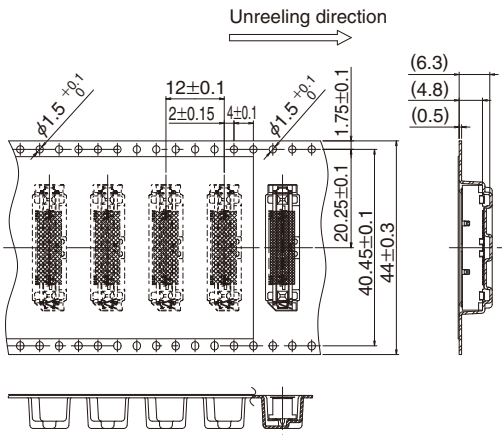

Part No.	HRS No.	No. of contacts	D
FX15-31S-0.5SV(**)	575-2201-7 **	31	44.5

### ● Right angle, with shields-enhanced shielding (FX15S-\*\*\*S-0.5SH)

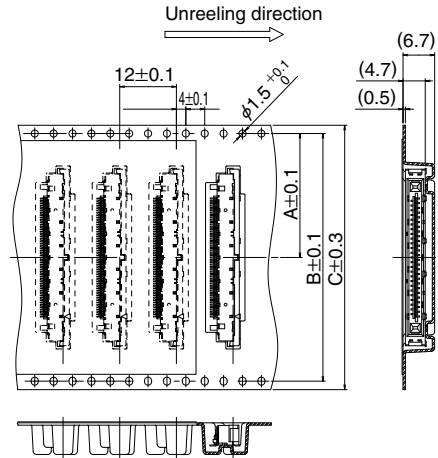

Part No.	HRS No.	No. of contacts	A	B	C	D
FX15S-31S-0.5SH(**)	575-2306-5 **	31	20.3	40.5	44	44.5
FX15S-41S-0.5SH(**)	575-2307-8 **	41	26.3	52.5	56	56.5
FX15S-51S-0.5SH(**)	575-2303-7 **	51				

### ● Right angle, without shields (FX15M-\*\*\*S-0.5SH)

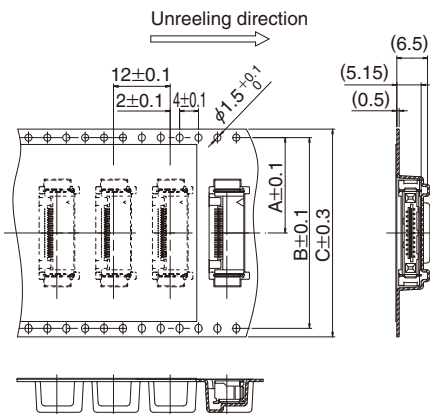

Part No.	HRS No.	No. of contacts	A	B	C	D
FX15M-21S-0.5SH(**)	575-2309-3 **	21	20.2	40.4	44	44.5
FX15M-31S-0.5SH(**)	575-2308-0 **	31				

### ● Reel dimensions

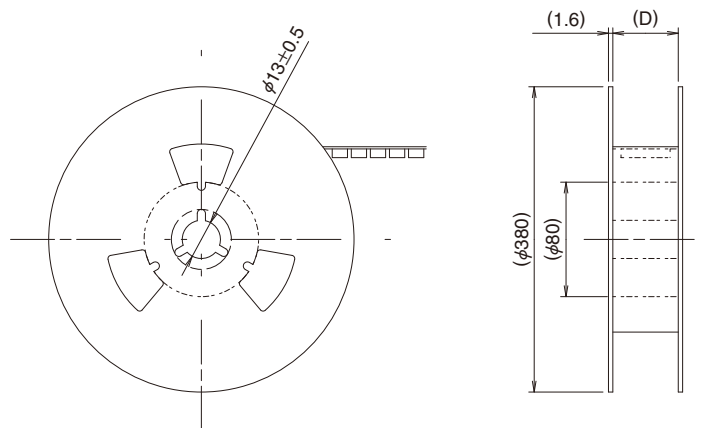

● Right angle with shields – enhanced shielding (FX15SC-\*\*-S-0.5SH) ● Vertical with shields – enhanced shielding (FX15SC-\*\*-S-0.5SV)

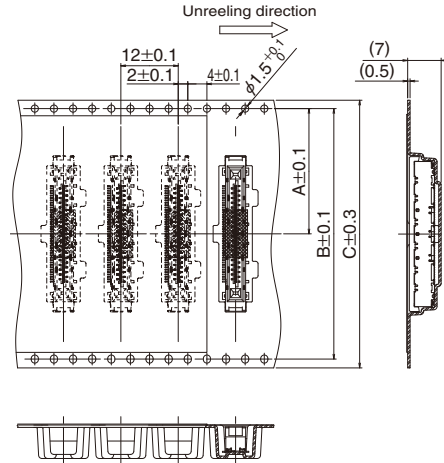
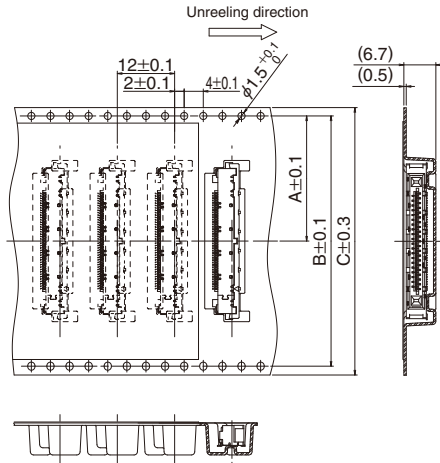

Part No.	HRS No.	No. of contacts	A	B	C	D	RoHS
FX15SC-41S-0.5SH(**)	575-2310-2 **	41	26.2	52.4	56	56.5	Yes
FX15SC-51S-0.5SH(**)	575-2311-5 **	51					

Part No.	HRS No.	No. of contacts	A	B	C	D	RoHS
FX15SC-41S-0.5SV(**)	575-2205-8 **	41	26.2	52.4	56	56.5	Yes
FX15SC-51S-0.5SV(**)	575-2204-5 **	51					

● Reel dimensions

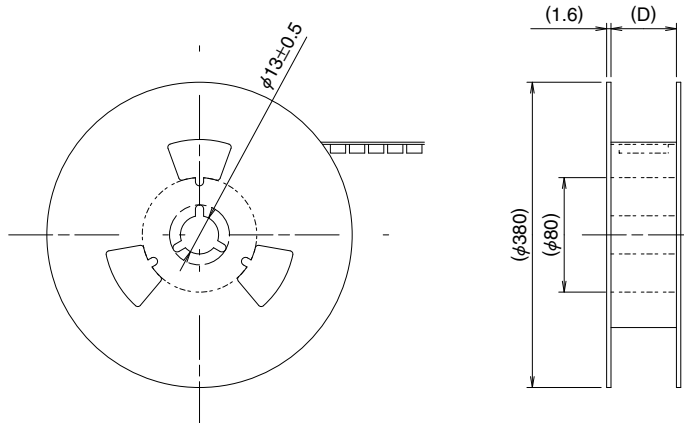

Dec.1.2021 Copyright 2021 HIROSE ELECTRIC CO., LTD. All Rights Reserved.



**Precautions and recommendations**

◆ Wire termination

The following documents will be needed in order to perform the cable terminations.

- ① Basic cable termination and crimp requirements (general explanations).
- ② Contact crimp termination machine instruction manual (Explanation of the press)
- ③ Applicator parts installation table (Applicator installation explanation)
- ④ Crimp conditions table (Crimp height/Tensile strength standard values)
- ⑤ Crimp quality fundamentals manual (Bell-mouth dimensions, bent up, bent down, rolling, etc.)

\* Correct cable preparation and crimp termination is based on understanding and following the procedures in the above documents.

◆ Insertion of the crimp contacts in the housing

Crimp contacts are inserted in the housing as illustrated below.

Exercising caution when inserting, align the retention tab of the contact with the corresponding molded-in lance in the housing's contact cavity and push the contacts in.

Make sure that the contact is fully inserted and the retention tab clears the molded-in lance.

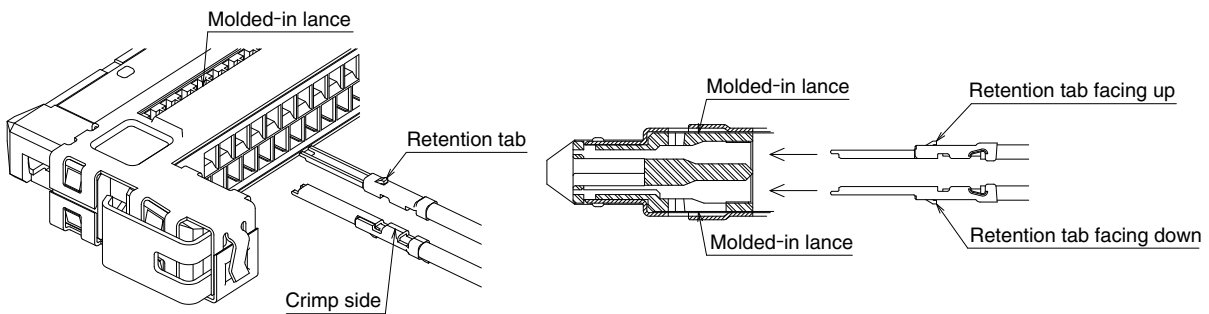

◆ Verify that the retention tabs clear the molded-in lances as shown on the illustration below.

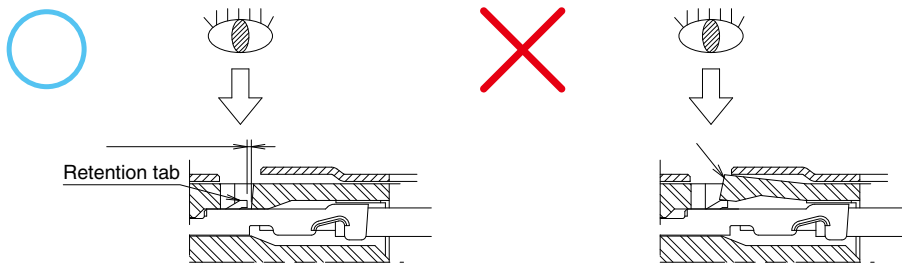

Light pull on the wire, with force NOT EXCEEDING 3N will also verify the correct contact insertion.

◆ Removal of the contacts

Using sharp-pointed tool of appropriate size gently lift the molded-in tab and pull-out the terminated contacts.

Excercise caution as NOT to damage the molded-in lance.

Should the damage occur, the entire housing will need to be replaced.

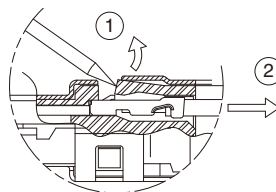



**Precautions and recommendations**

[ Soldering precautions related to FX15S-\*\*P-C connectors ]

◆Grounding Methods of the ground wire or shields for the cable assemblies

- ① Solder the ground wire or the shields ONLY in the areas specifically designated for this purpose, as shown on the illustrations below.
- ② Observe the soldering iron tip temperature and soldering time specified.
- ③ Do not apply excessive force to the connector by pressing it with the tip of a soldering iron.
- ④ Do not splatter the flux from the solder core.

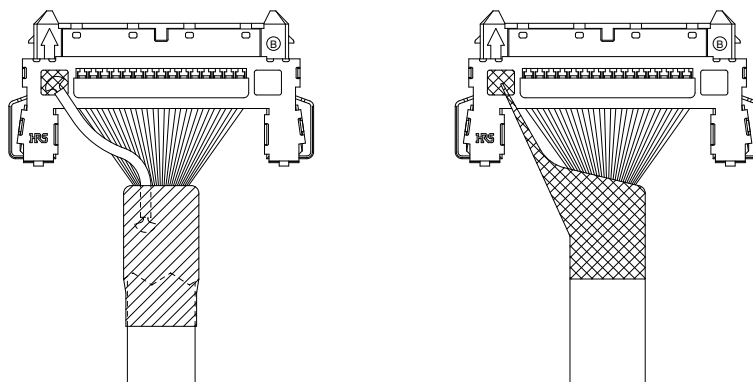
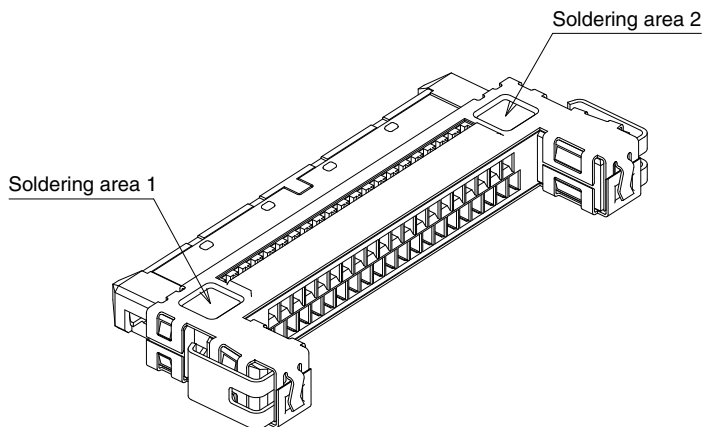

(Ground harness examples)

**Precautions and recommendations**

◆ Plug – micro-coaxial cable

**Cautions for soldering**

1. For the micro coaxial cable assembled to this connector, cable alignment process as shown in "Recommended cable" on the page 1 is required before assembly.

① Width of ground bar shall be 1.05mm Max. including misalignment of overlapping, flush by cutting, side drop or soldering. Using an inadequate cable will interfere the assembly to the connector. Forceful assembly and soldering could cause mis-soldering and damage the product.

② Minimize the length of outer conductor beyond the ground the bar.

③ Length of cutting the extra cable should be 2.1mm Max. Any longer cable may cause contact with the connector during assembly and could damage the product. Recommended minimum length is 2.0mm, but this can be altered as long as good soldering ability is maintained.

④ Pre-solder and coat the inner conductor at the cable end.

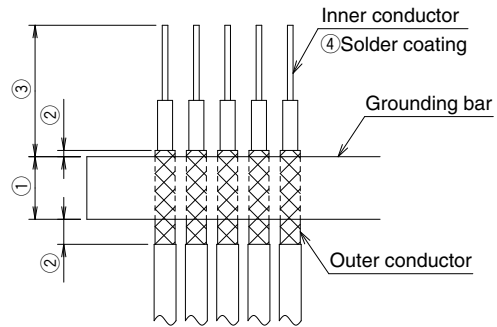

2. Recommended solder for the assembly is flux cored solder with 0.2mm dia. (Lead-free: Sn-3Ag-0.5Cu), 21mm length. If additional flux is used, make sure to prevent wicking onto the contact area. Wicking onto the contact area will cause the contacts to fail.

3. Before soldering the cable and connector with a cable assembly machine, check the points to avoid below.

- ① Misalignment of cable end to the terminals in pitch direction
- ② Excessive floating of cable end

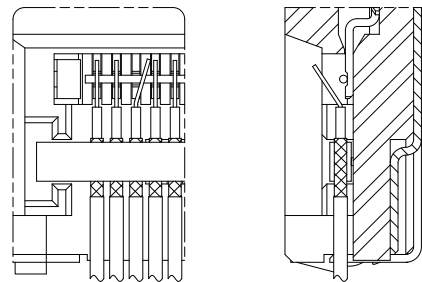

4. Follow the recommended temperature profile shown below for the soldering.

The optimum conditions for soldering can vary depending on cable type and length, and solder type. Be sure to check the recommended temperate profile and adjust the conditions accordingly.

Solder tip pressurization	13~17N
Heating	
Temperature	265±5°C
Duration	3~4 sec

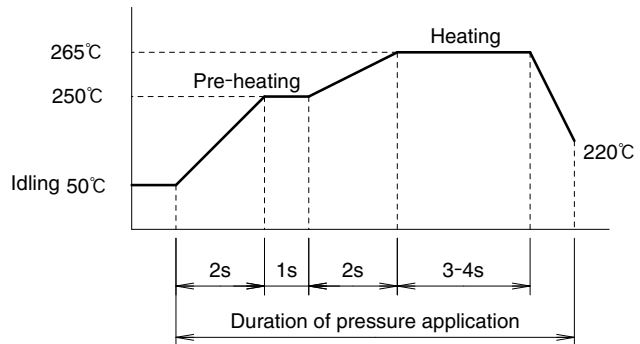

**Precautions and recommendations**

5. After soldering, check that no defect is found at soldered area.  
 Examples of correct soldered and defective soldered state are shown below.

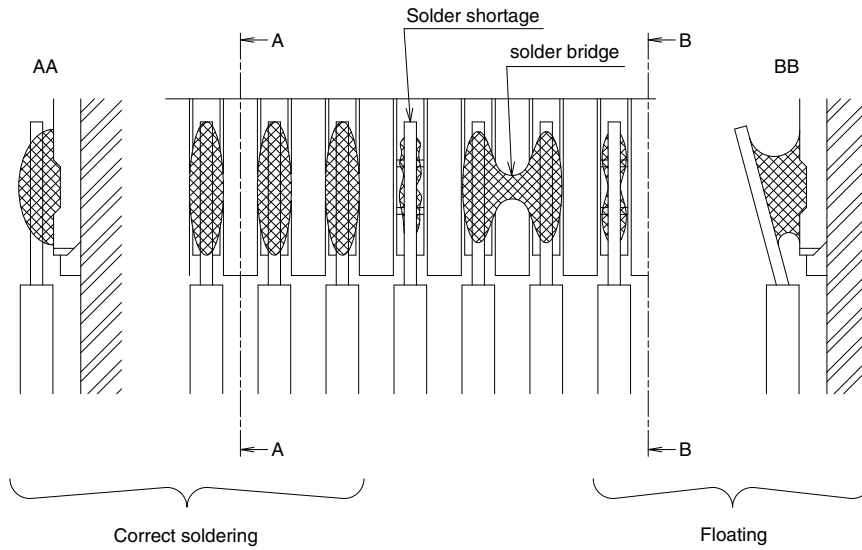

[ Cautions for potting process ]

1. Protect the soldered area by UV cured resin (referred as "potting" hereafter), in order to prevent cable breakage during cabling and other issues.
2. Apply 3033 manufactured by THREEBOND CO., LTD. or any equivalent product for potting. Follow the instruction of the potting manufacturer for UV curing exposure.
3. Refer to the following conditions the potting area.

Number of contacts	A
41	23.7
51	28.7

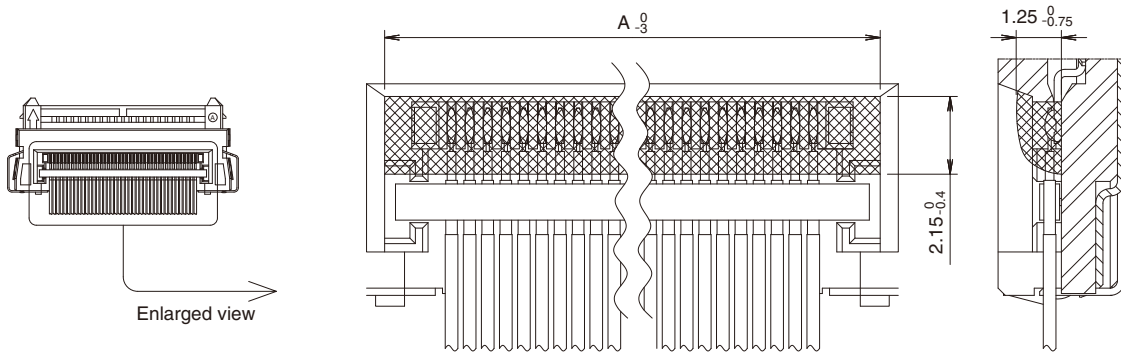

4. Use extreme care in handling the soldered and potted assembly. Too much stress applied to the cable could break it.

**Precautions and recommendations**

[ Cautions for ground plate assembly ]

1. Attach a ground plate separately provided as FX15S-41P-GND after the cable assembly process.
2. Place the ground plate onto the connector horizontally and pinch the two components from top and bottom with your fingers.

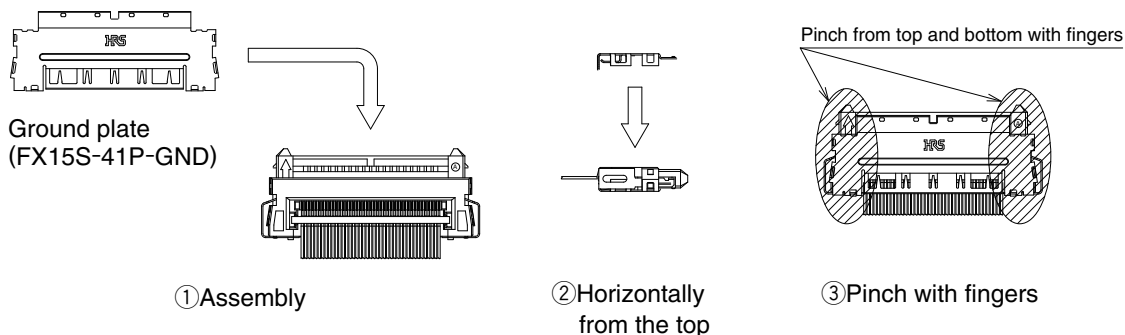

3. Check the six fitting points after assembly and make sure that they are all correctly fitted together.

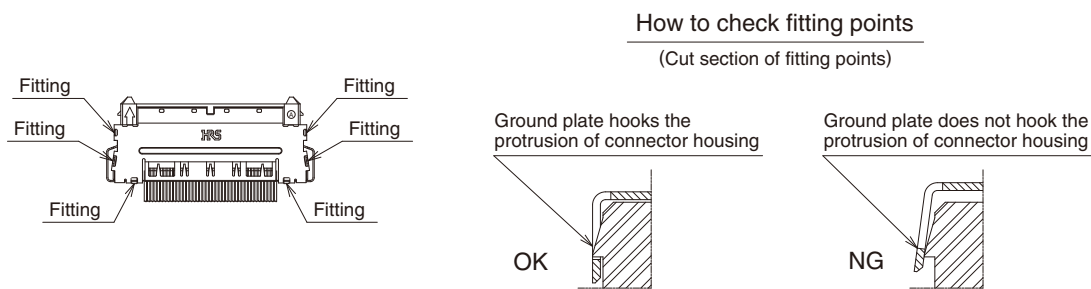

[ Soldering to ground plate ]

1. Solder down the metal bar of the cable and ground plate after the assembly of the ground plate to enhance grounding capability and to protect against vertical cable pulling forces.

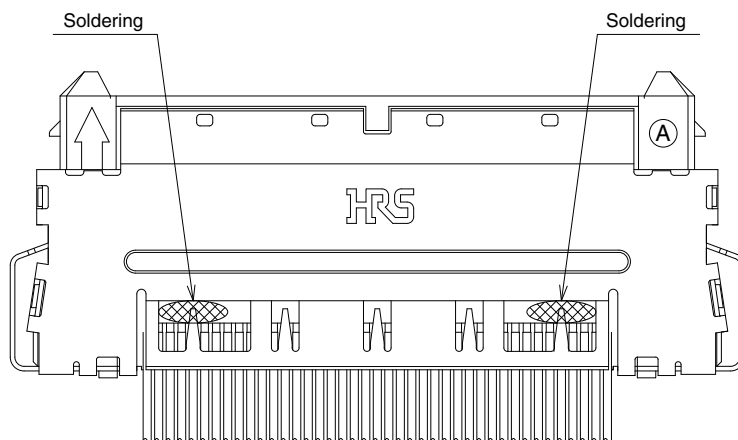

Dec.1.2021 Copyright 2021 HIROSE ELECTRIC CO., LTD. All Rights Reserved.

### Precautions and recommendations

◆Packaging of the complete cable assemblies

Exercise caution as not to tangle, twist or deform the complete cable assemblies when packaging. Special care should be taken NOT to apply any excessive stress to the individual wires. When removing the cable assemblies from the packaging do not pull on the wires. Make sure that the latch-locks are not interfering with packaging.

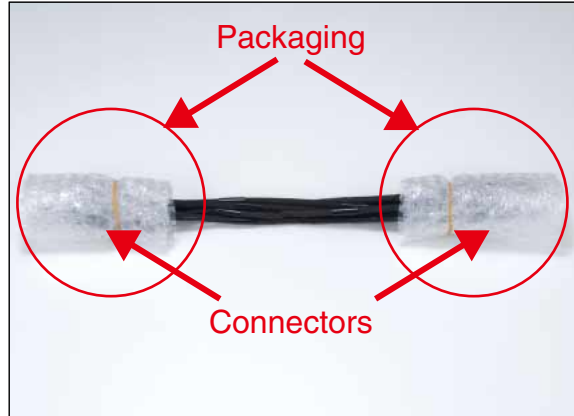

◆Mating of the connectors

These connectors have a built in polarizing feature and will NOT mate when reversed. Do NOT try and force them together. Align the connectors as shown on the illustration below and fully insert the plug into the receptacle. Confirm that both latch-locks are fully engaged.

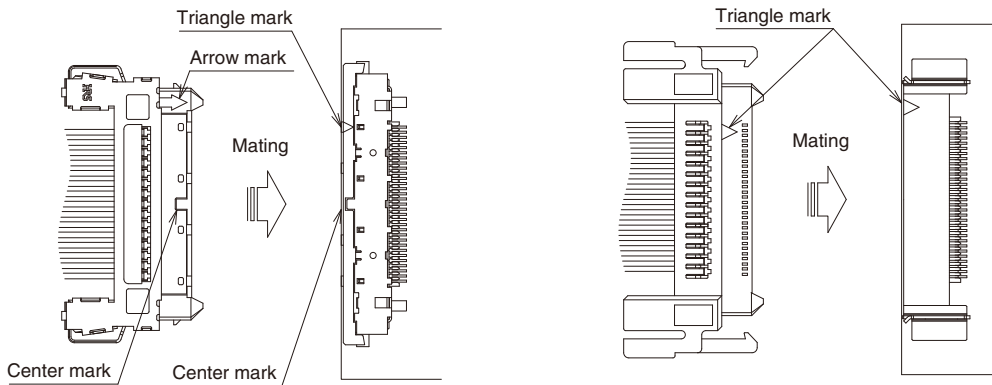

Additionally, this connector is equipped with reverse-insertion preventing mechanism, but a forced mating with a minimum force of 25N could damage the connector.

Avoid any inappropriate mating, and perform the mating operation after checking the above-mentioned polarity indication.

◆Treatment after mating has been completed

After mating, please take care to prevent any stress or load on the connector during the routing of cables. If a load of a minimum of 5N is applied on the cable, the cable (crimp contact) could come off. Further, if the entire cable is pulled with a minimum force of 20N, the connector could be broken. Please take extra care not to pull the cable and cause cable disconnection.

If you use a small gauge coaxial plug, a repeated rotation could also cause cable disconnection. Do not use the cable by rotating it repeatedly. The rotation times should be limited to a maximum of 10 even if rotation is required for routing. If your use requires folding back of the cable over the base of the connector, make sure to maintain a large turn-back radius away from the connector base.

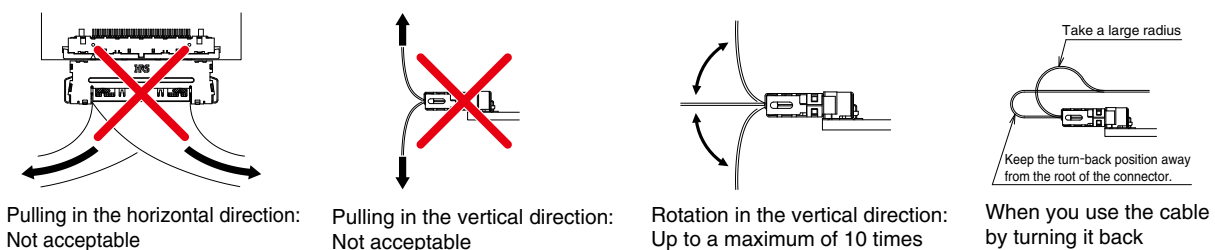



## ◆ Technical Information (FX15S Series)

### ● Eye Pattern Waveforms (700MHz)

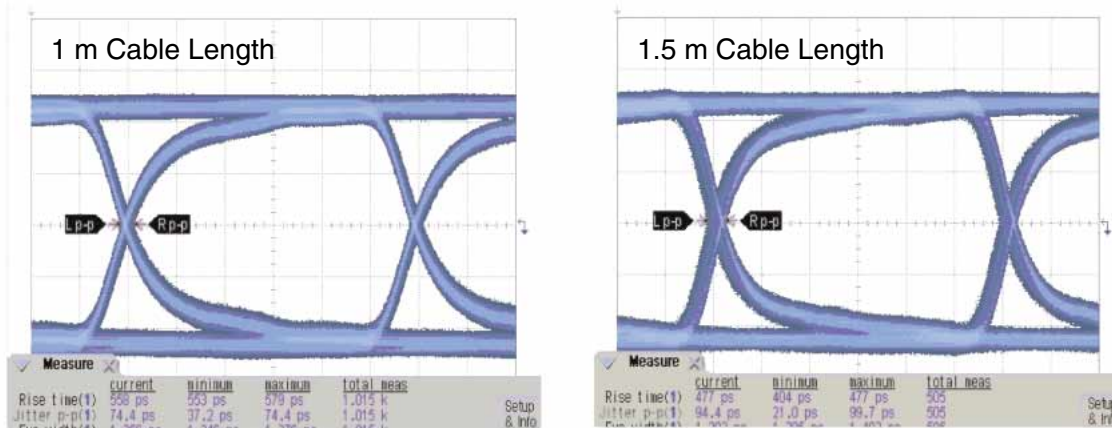

### ● Shielding Effectiveness (Shielding Characteristics Comparison Using a 2-chamber Shielded Room)

Measured shielding effectiveness for frequencies from 100MHz to 2GHz.

Shielded connectors show noise suppression of 10db to 20dB, when compared with connectors without the shields.

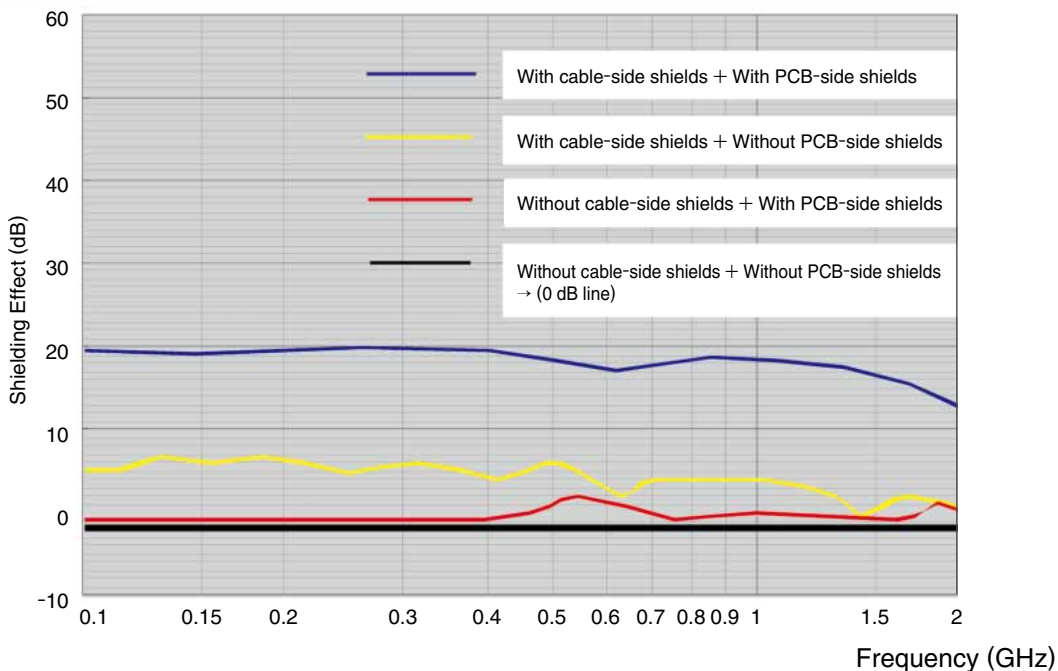

Notes :The measurement value of “Without plug-side shields + Without receptacle-side shields” are taken as the zero level of the graph vertical axis dB.

The respective results express the noise suppression effect (dB) as a relative comparison value to the “without shields” condition as the reference.

**USA:**

**HIROSE ELECTRIC (U.S.A.), INC. HEADQUARTERS**  
 2688 Westhills Court, Simi Valley, CA 93065-6235  
 Phone : +1-805-522-7958  
 Fax : +1-805-522-3217  
<http://www.hirose.com/us/>

**USA:**

**HIROSE ELECTRIC (U.S.A.), INC. SAN JOSE OFFICE**  
 3255 Scott Boulevard, Building 7, Suite 101  
 Santa Clara, CA 95054  
 Phone : +1-408-253-9640  
 Fax : +1-408-253-9641  
<http://www.hirose.com/us/>

**USA:**

**HIROSE ELECTRIC (U.S.A.), INC. CHICAGO OFFICE**  
 580 Waters Edge Lane, Suite 205 Lombard IL  
 60148  
 Phone : +1-630-282-6701  
 Mail : [inquiries@hirose.com](mailto:inquiries@hirose.com)  
<http://www.hirose.com/us/>

**USA:**

**HIROSE ELECTRIC (U.S.A.), INC. DETROIT OFFICE (AUTOMOTIVE)**  
 17197 N. Laurel Park Drive, Suite 253, Livonia,  
 MI 48152  
 Phone : +1-734-542-9963  
 Fax : +1-734-542-9964  
<http://www.hirose.com/us/>

**THE NETHERLANDS:**

**HIROSE ELECTRIC EUROPE B.V.**  
 Hogehillweg #8 1101 CC Amsterdam Z-0  
 Phone : +31-20-6557460  
 Fax : +31-20-6557469  
<http://www.hirose.com/eu/>

**GERMANY:**

**HIROSE ELECTRIC EUROPE B.V. GERMAN BRANCH**  
 Herzog-Carl-Strasse 4 D-73760 Ostfildern  
 (Scharnhäuser Park)  
 Phone : +49-711-4560-02-1  
 Fax : +49-711-4560-02-299  
<http://www.hirose.com/eu/>

**GERMANY:**

**HIROSE ELECTRIC EUROPE B.V. NUERNBERG OFFICE**  
 Muggenhofer Str. 136 90429 Nuernberg  
 Phone : +49-911 32 68 89 63  
 Fax : +49-911 32 68 89 69  
<http://www.hirose.com/eu/>

**GERMANY:**

**HIROSE ELECTRIC EUROPE B.V. HANOVER OFFICE**  
 Bayernstr. 3, Haus C 30855 Langenhagen, Germany  
 Phone : +49-511 97 82 61 30  
 Fax : +49-511 97 82 61 35  
<http://www.hirose.com/eu/>

**FRANCE:**

**HIROSE ELECTRIC EUROPE B.V. PARIS OFFICE**  
 Regus La Garenne Colombes, Place de La Belgique,  
 71 Boulevard National La Garenne Colombes, 92250, France  
 Phone : +33 (0) 1 7082 3170  
 Fax : +33 (1) 7082 3101  
<http://www.hirose.com/eu/>

**UNITED KINGDOM:**

**HIROSE ELECTRIC EUROPE BV (UK BRANCH)**  
 4 Newton Court, Kelvin Drive, Knowlhill,  
 Milton Keynes, MK5 8NH  
 Phone : +44-1908 202050  
 Fax : +44-1908 202058  
<http://www.hirose.com/eu/>

**CHINA:**

**HIROSE ELECTRIC (SHANGHAI) CO., LTD.**  
 1601, Henderson Metropolitan, NO.300, East Nanjing  
 Road, Huangpu District, Shanghai, China 200001  
 Phone : +86-21-6391-3355  
 Fax : +86-21-6391-3335  
<http://www.hirose.com/cn/>

**CHINA:**

**HIROSE ELECTRIC (SHANGHAI) CO.,LTD. BEIJING BRANCH**  
 A1001, Ocean International Center, Building 56# East 4th  
 Ring Middle Road, ChaoYang District, Beijing, 100025  
 Phone : +86-10-5165-9332  
 Fax : +86-10-5908-1381  
<http://www.hirose.com/cn/>

**CHINA:**

**HIROSE ELECTRIC TECHNOLOGIES (SHENZHEN) CO., LTD.**  
 Room 09-13, 19/F, Office Tower Shun Hing Square, Di Wang Commercial Centre,  
 5002 Shen Nan Dong Road, Shenzhen City, Guangdong Province, 518008  
 Phone : +86-755-8207-0851  
 Fax : +86-755-8207-0873  
<http://www.hirose.com/cn/>

**HONG KONG:**

**HIROSE ELECTRIC HONGKONG TRADING CO., LTD.**  
 Room 1001, West Wing, Tsim Sha Tsui Centre, 66  
 Mody Road, Tsim Sha Tsui East, Kowloon, Hong Kong  
 Phone : +852-2803-5338  
 Fax : +852-2591-6560  
<http://www.hirose.com/hk/>

**TAIWAN:**

**HIROSE ELECTRIC TAIWAN CO., LTD.**  
 103 8F, No.87, Zhengzhou Rd., Taipei  
 Phone : +886-2-2555-7377  
 Fax : +886-2-2555-7350  
<http://www.hirose.com/tw/>

**KOREA:**

**HIROSE KOREA CO., LTD.**  
 250, Huimanggongwon-ro, Siheung-si,  
 Gyeonggi-do, Korea, 429-849  
 Phone : +82-31-496-7000,7124  
 Fax : +82-31-496-7100  
<http://www.hirose.co.kr/>

**SINGAPORE:**

**HIROSE ELECTRIC SINGAPORE PTE. LTD.**  
 10 Anson Road #26-16, International Plaza  
 079903, Singapore  
 Phone : +65-6324-6113  
 Fax : +65-6324-6123  
<http://www.hirose.com/sg/>

**INDIA:**

**HIROSE ELECTRIC SINGAPORE PTE. LTD. DELHI LIAISON OFFICE**  
 Office NO.519, Regus-Green Boulevard, Level5, Tower C,  
 Sec62, Plot B-9A, Block B, Noida, 201301, Uttar Pradesh, India  
 Phone : +91-12-660-8018  
 Fax : +91-120-4804949  
<http://www.hirose.com/sg/>

**INDIA:**

**HIROSE ELECTRIC SINGAPORE PTE. LTD. BANGALORE LIAISON OFFICE**  
 Unit No-403, 4th Floor, No-84, Barton Centre, Mahatma  
 Gandhi (MG) Road, Bangalore 560 001, Karnataka, India  
 Phone : +91-80-4120 1907  
 Fax : +91-80-4120 9908  
<http://www.hirose.com/sg/>

**MALAYSIA:**

**HIROSE ELECTRIC SINGAPORE PTE. LTD.**  
 1-10-07, Suntech @ Penang Cybercity (1164), Lintang  
 Mayang Pasir 3,11950, Bayan Baru, Penang, Malaysia.  
 Phone : +604-619-2564  
 Fax : +604-619-2574  
<http://www.hirose.com/sg/>

**THAILAND:**

**HIROSE ELECTRIC SINGAPORE PTE. LTD. BANGKOK OFFICE (REPRESENTATIVE OFFICE)**  
 Unit 4703, 47th FL., 1 Empire Tower, South Sathorn  
 Road, Yannawa, Sathorn, Bangkok 10120 Thailand  
 Phone : +66-2-686-1255  
 Fax : +66-2-686-3433  
<http://www.hirose.com/sg/>



**HIROSE ELECTRIC CO.,LTD.**

2-6-3,Nakagawa Chuoh,Tsuzuki-Ku,Yokohama-Shi 224-8540,JAPAN  
 TEL: +81-45-620-3526 Fax: +81-45-591-3726  
<http://www.hirose.com>  
<http://www.hirose-connectors.com>



## X-ON Electronics

Largest Supplier of Electrical and Electronic Components

*Click to view similar products for [Headers & Wire Housings](#) category:*

*Click to view products by [Hirose](#) manufacturer:*

Other Similar products are found below :

[892-18-020-10-001101](#) [58102-G61-06LF](#) [582553-1](#) [0009485154](#) [009176003701906](#) [0050291907](#) [LY20-4P-DT1-P1E-BR](#) [02.125.8002.8](#)  
[609-3404](#) [61062-3](#) [622-0430](#) [622-3653LF](#) [63453-116](#) [636-1030](#) [636-1427](#) [636-3427](#) [636-4007](#) [641938-9](#) [641991-4](#) [644827-2](#) [65817-010LF](#)  
[65817-015LF](#) [65863-015LF](#) [66207-023LF](#) [67095-007LF](#) [67601157](#) [68648-049](#) [70.362.1628.0](#) [70-4210](#) [70-4226B](#) [70-4853B](#) [707-5020](#) [707-5028](#) [71.350.2428.0](#) [71918-208LF](#) [71961-016LF](#) [733-134](#) [733-162](#) [754199-000](#) [760-3052](#) [787-8014-00](#) [79531-3000](#) [FCN-360C032-B](#) [FCN-367T-T012/H](#) [FCN-723D010/2](#) [80.063.4001.1](#) [800-90-001-10-001000](#) [800-90-010-10-002000](#) [801-43-002-10-013000](#) [801-43-006-10-002000](#)