

Sep.1.2021 Copyright 2021 HIROSE ELECTRIC CO., LTD. All Rights Reserved.
In case of consideration for using Automotive equipment / device which demand high reliability, kindly contact our sales window correspondents.

RECOMMENDED LAND PATTERN DIMENSION OF PCB
(PCB THICKNESS: $t=1.6\text{mm}$)

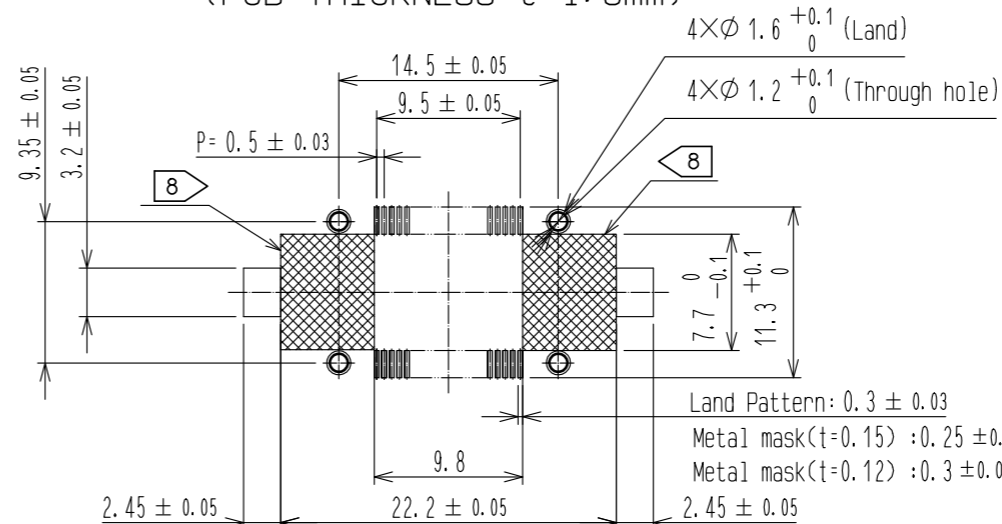

③ FLOATING RANGE

X DIRECTION: $\pm 0.6\text{mm}$
Y DIRECTION: $\pm 0.6\text{mm}$

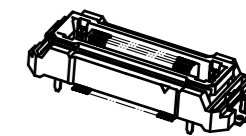

△ CROSS SECTION OF MATING
(No scale)

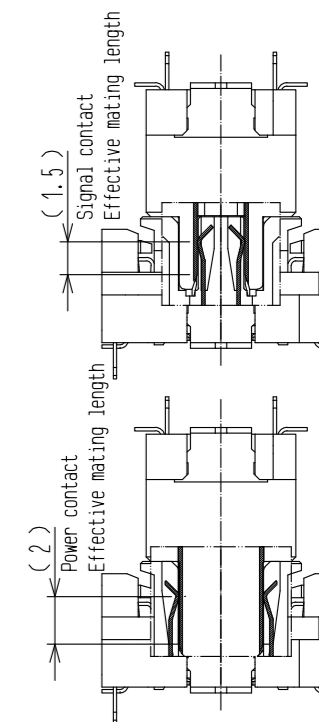

⑦ PCB DISTANCE (No scale)

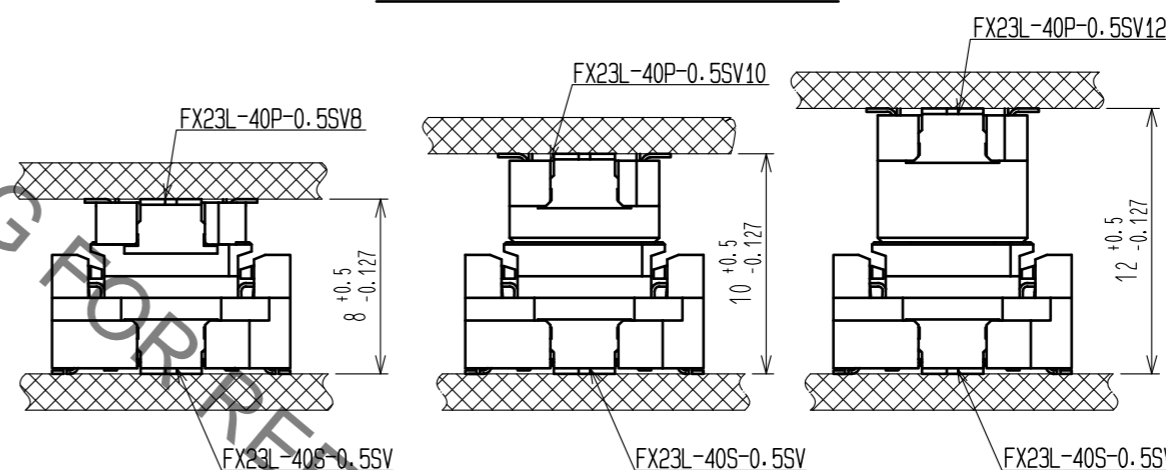

- Note
- 1 Lead CO-Planarity is 0.1mm MAX.
 - 2 This is packaged in tray. (80pcs/tray)
 - 3 Floating range of this connector is $\pm 0.6\text{mm}$ MAX.
 - △ The maximum cycle time of the floating operation is in accordance with the mating cycle of the connector.
 - 4 It shows the vacuum pickup area. Remove the mylar tape before mating connectors.
 - 5 Blemish and hit mark can be occurred through out the manufacturing process which doesn't affect quality level.
 - 6 The dimensions in parentheses are for references.
 - 7 Please use the connectors within the specified PCB distance.
 - 8 area of inner SMT land requires pattern prohibition or resist treatment to prevent the pattern.

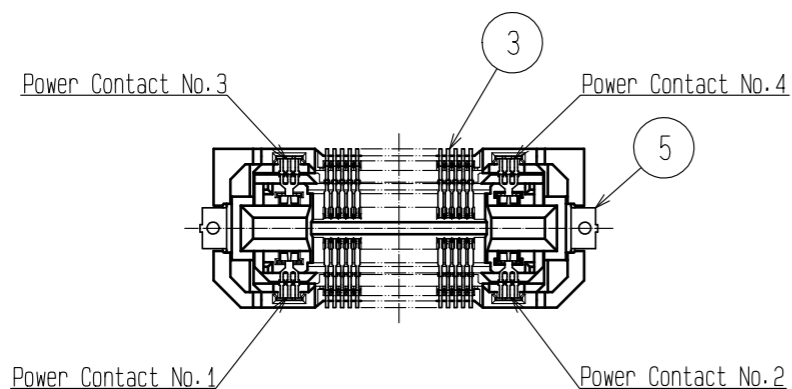
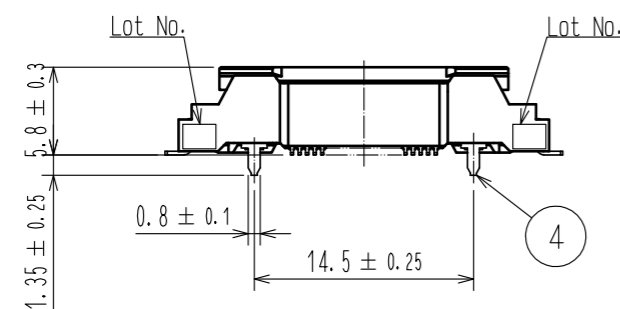
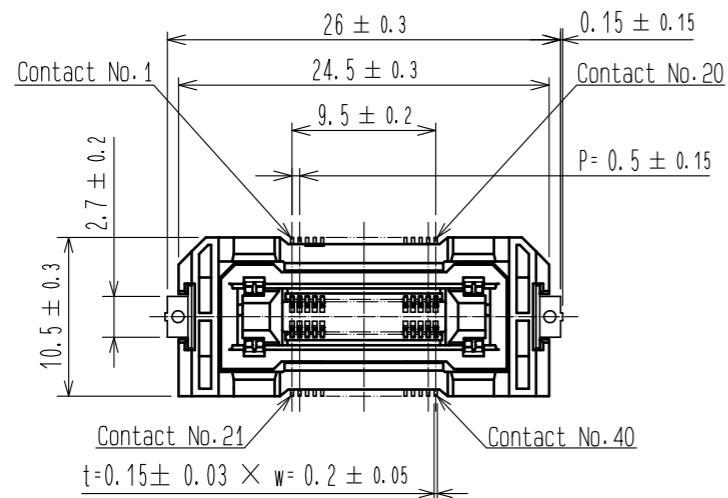

② DRAWING FOR PACKING (No scale)

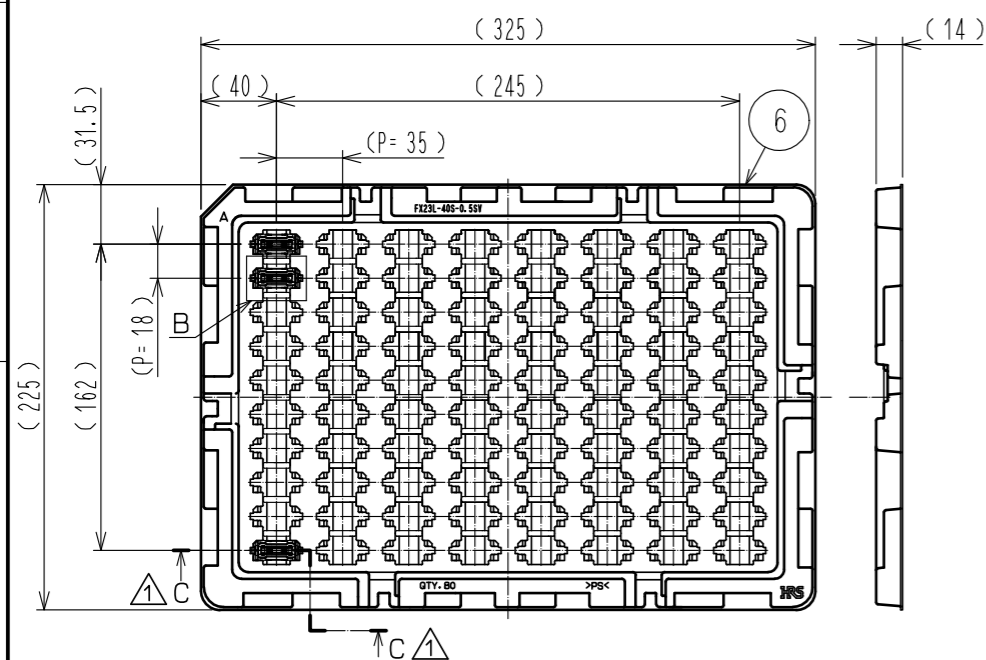

B (1:1)

△ C-C (1:1)

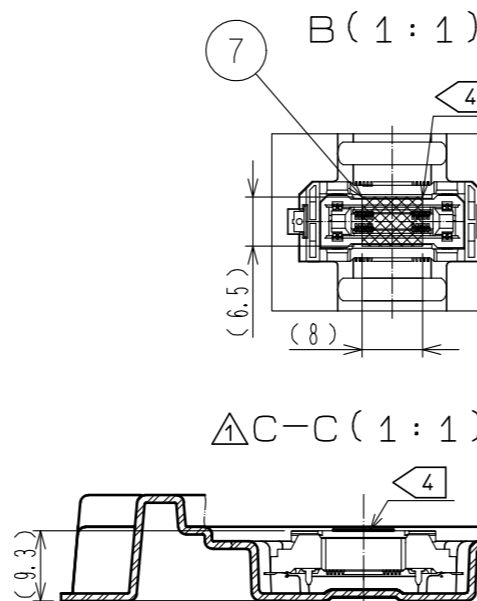

NO.	MATERIAL	FINISH . REMARKS	NO.	MATERIAL	FINISH . REMARKS
3	COPPER ALLOY	CONTACT AREA:GOLD 0.1 μm LEAD AREA:GOLD 0.03 μm UNDER PLATING:NICKEL 1.3 μm	7	POLYIMIDE △	(TAPE FOR VACUUM PICKUP)
2	POLYAMIDE	BLACK UL94V-0	6	POLYSTYRENE	(TRAY)
1	POLYAMIDE	BLACK UL94V-0	5	BRASS	TIN-PLATING 1 μm
			4	COPPER ALLOY	CONTACT AREA:GOLD 0.1 μm LEAD AREA:TIN-PLATING 1 μm UNDER PLATING:NICKEL 1.3 μm

UNITS	SCALE	COUNT	DESCRIPTION OF REVISIONS	DESIGNED	CHECKED	DATE
mm	2 : 1	1	DIS-F-00004372	TS.00NO	HT.YAMAGUCHI	20190307

APPROVED	DATE	DRAWING NO.
HS. OKAWA	20150224	EDC-358065-00-00
CHECKED	DATE	PART NO.
KN. SHIBUYA	20150224	FX23L-40S-0.5SV
DESIGNED	DATE	CODE NO.
AH. EDASHIGE	20150224	CL573-2302-1-00
DRAWN	DATE	
AH. EDASHIGE	20150224	

X-ON Electronics

Largest Supplier of Electrical and Electronic Components

Click to view similar products for [Board to Board & Mezzanine Connectors](#) category:

Click to view products by [Hirose](#) manufacturer:

Other Similar products are found below :

[589158040000018](#) [MDF7C-18P-2.54DSA\(55\)](#) [FCN-230C068-11](#) [FCN-268F012-G/BD](#) [FCN-268F036-G/BD](#) [FCN-268M012-G/0D](#) [FCN-268M024-G/1D](#) [FCN-723J004/1](#) [MIS-048-01-F-D-DP-K](#) [832-10-034-10-001000](#) [FX4C-80S-1.27DSA](#) [FCN-214Q030-G/0](#) [FCN-234P048-G/0](#) [FCN-235D050-G/C](#) [210-93-314-41-105000](#) [2-22603-0](#) [MDF7-40DP-2.54DSA\(55\)](#) [AXG720047](#) [MIT-114-03-F-D-K](#) [55323-1519](#) [DF33-2P-3.3DSA\(24\)](#) [YFT-20-05-H-03-SB-K](#) [503308-3040](#) [026-6203-PDB](#) [027-6203-PDB](#) [069159702701000](#) [10123981-102LF](#) [101A10019X](#) [55650-0588-C](#) [68682-310LF](#) [68684-306](#) [75140-7012](#) [87471-650](#) [YTW-30-07-H-Q-410-140](#) [FCN-268F024-G0D](#) [10124054-515LF](#) [68685-603](#) [8-1616154-3](#) [MIS-019-01-F-D](#) [FCN-268M024-G/3D](#) [FCN-268M036-G/BD](#) [20021832-06016C1LF](#) [KX15-20KLDL-E1000E](#) [AXE810124](#) [FCN-214J100-G/0](#) [FCN-230C068-E/S](#) [AXE812124](#) [AXE816124](#) [AXE720127](#) [354184](#)