

Sep.1.2021 Copyright 2021 HIROSE ELECTRIC CO., LTD. All Rights Reserved.  
 In case of consideration for using Automotive equipment / device which demand high reliability, kindly contact our sales window correspondents.

ELV, RoHS COMPLIANT

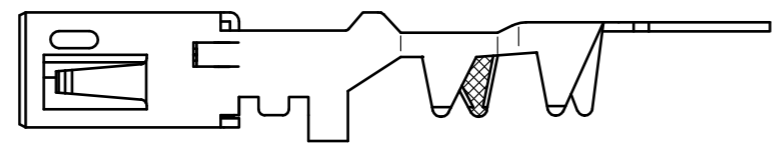
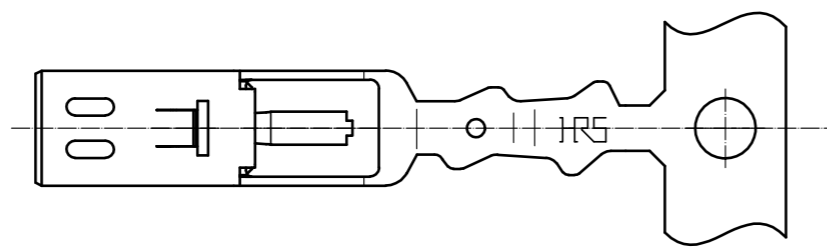
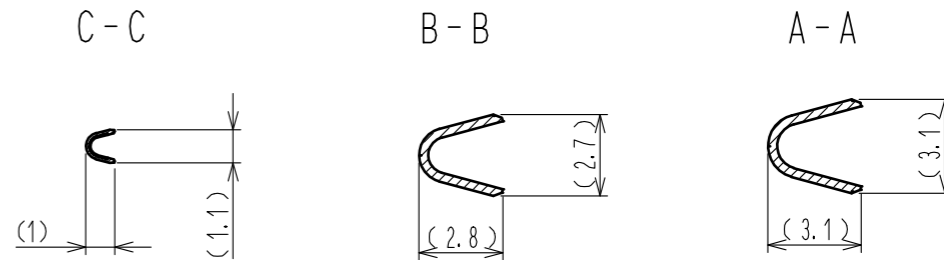
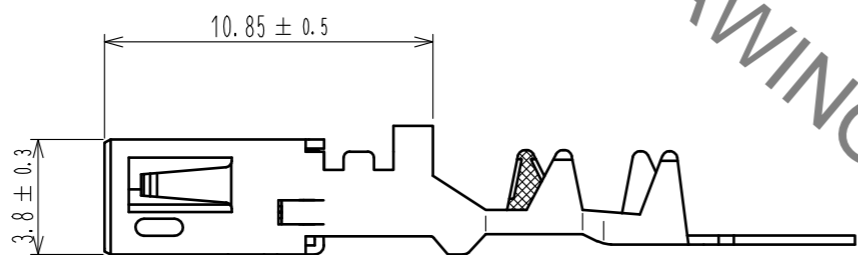
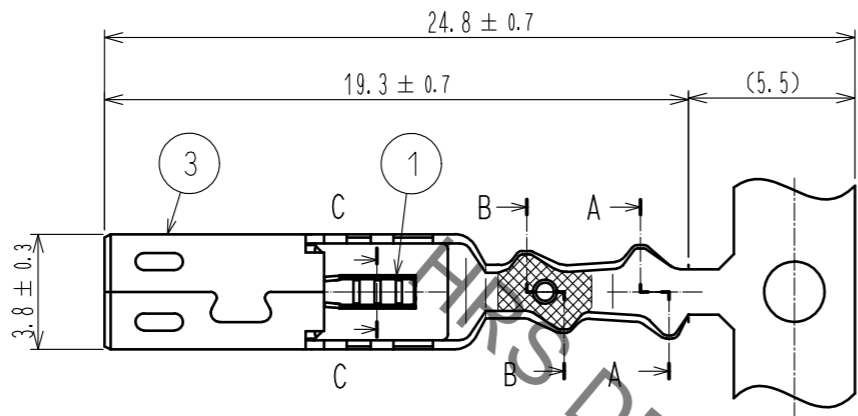

- NOTES  
 1. PER REEL: 5000 CONTACTS.  
 2. THIS REEL DIAMETER SHALL BE  $\phi 800$ . AND CRIMPING MACHINE NEEDS ADDITIONAL PARTS AS CM105/RS-ED.

2	PBT	UL94HB. BLACK			
1	BRASS	TIN PLATED	3	BRASS	TIN PLATED
NO.	MATERIAL	FINISH . REMARKS	NO.	MATERIAL	FINISH . REMARKS
UNITS mm		SCALE 4 : 1	COUNT 	DESCRIPTION OF REVISIONS	DESIGNED
		APPROVED : NH. NAKATA	15.10.22	DRAWING NO.	EDC-168895-00-00
HIROSE ELECTRIC CO., LTD.		CHECKED : KI. HIROKAWA	15.10.21	PART NO.	GT21-30/0.7-1.5PCF
		DESIGNED : KK. FURUKAWA	15.10.20	CODE NO.	CL771-0056-0-00
		DRAWN : KK. FURUKAWA	15.10.20		

## X-ON Electronics

Largest Supplier of Electrical and Electronic Components

*Click to view similar products for [Automotive Connectors](#) category:*

*Click to view products by [Hirose](#) manufacturer:*

Other Similar products are found below :

[003-018-000](#) [60403001](#) [60993906-B](#) [M902-2131](#) [M902-2161](#) [72.330.1035.1](#) [73.353.4028.0](#) [F119300-B](#) [F166900](#) [F258300-B](#) [F358300-B](#)  
[F407400](#) [F444110](#) [F487000](#) [F509500B-B](#) [827153-1](#) [8N1515-32-24P](#) [9-1326729-8](#) [925474-1](#) [928905-1](#) [964562-4](#) [968782-1](#) [GT17SA-8DS-](#)  
[HU](#) [98891-1012](#) [98947-1016](#) [12004475-L](#) [12010290](#) [12010309-B](#) [12015454](#) [12020219-B](#) [12020308](#) [12041318-B](#) [12052225-L](#) [12052466](#)  
[12059125](#) [12064869](#) [12004327-B](#) [12010503-B](#) [12015308](#) [12015384](#) [12015909](#) [1-21030-1](#) [12041254](#) [12041318](#) [12047946-B](#) [12047957](#)  
[12047957-L](#) [12059473](#) [12066261](#) [12110546](#)