

Sep.1.2021 Copyright 2021 HIROSE ELECTRIC CO., LTD. All Rights Reserved.
In case of consideration for using Automotive equipment / device which demand high reliability, kindly contact our sales window correspondents.

| 1 | | 2 | | 3 | | 4 | | | |
|-------|--------------------------|----|------|------|-------|--------------------------|----|------|------|
| COUNT | DESCRIPTION OF REVISIONS | BY | CHKD | DATE | COUNT | DESCRIPTION OF REVISIONS | BY | CHKD | DATE |
| △ | | | | | △ | | | | |
| △ | | | | | △ | | | | |
| △ | | | | | △ | | | | |

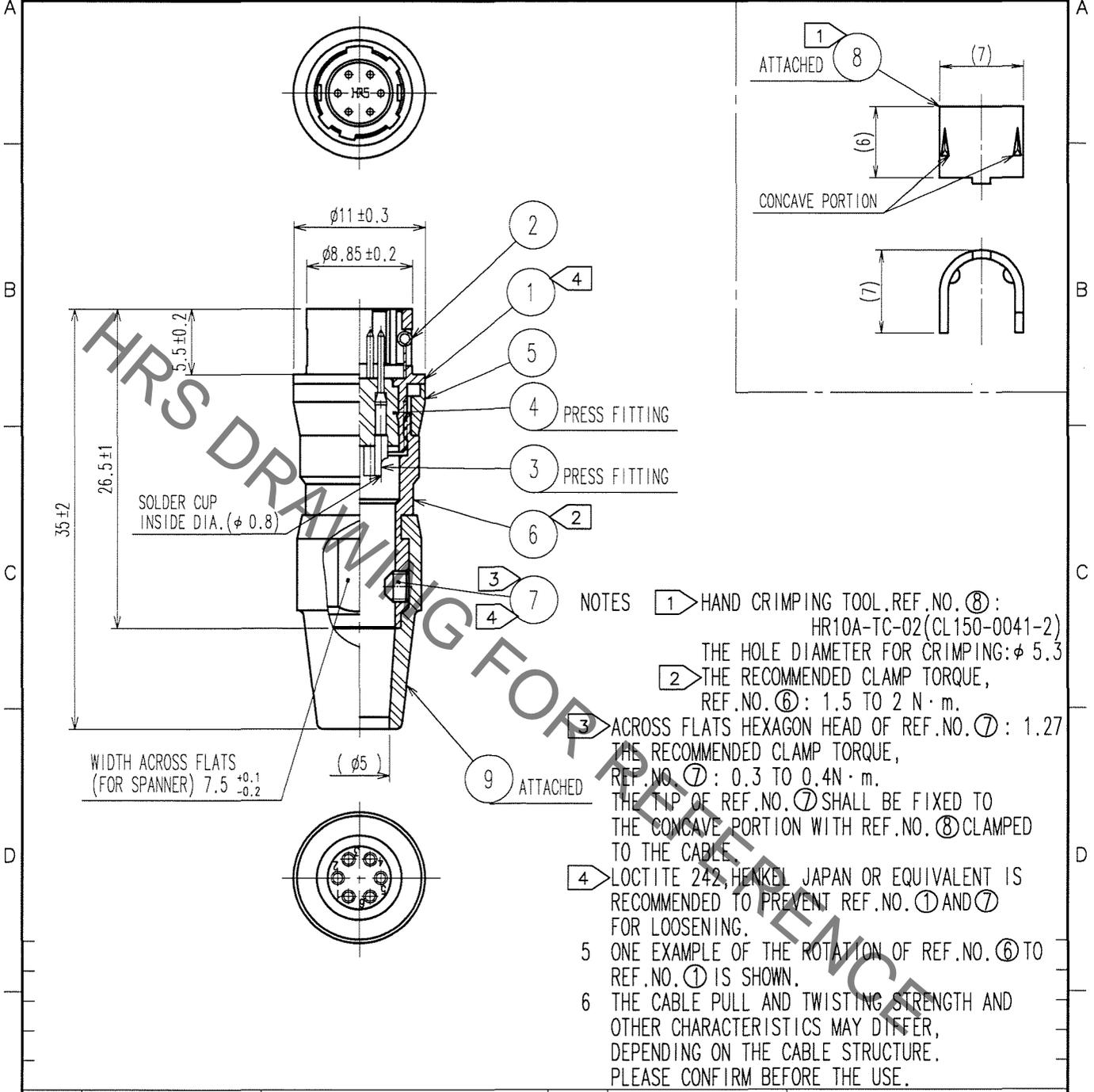

- NOTES
- ① HAND CRIMPING TOOL, REF. NO. ⑧ : HR10A-TC-02 (CL150-0041-2)
THE HOLE DIAMETER FOR CRIMPING: $\phi 5.3$
 - ② THE RECOMMENDED CLAMP TORQUE, REF. NO. ⑥ : 1.5 TO 2 N·m.
 - ③ ACROSS FLATS HEXAGON HEAD OF REF. NO. ⑦ : 1.27
THE RECOMMENDED CLAMP TORQUE, REF. NO. ⑦ : 0.3 TO 0.4 N·m.
THE TIP OF REF. NO. ⑦ SHALL BE FIXED TO THE CONCAVE PORTION WITH REF. NO. ⑧ CLAMPED TO THE CABLE.
 - ④ LOCTITE 242, HENKEL JAPAN OR EQUIVALENT IS RECOMMENDED TO PREVENT REF. NO. ① AND ⑦ FOR LOOSENING.
 - ⑤ ONE EXAMPLE OF THE ROTATION OF REF. NO. ⑥ TO REF. NO. ① IS SHOWN.
 - ⑥ THE CABLE PULL AND TWISTING STRENGTH AND OTHER CHARACTERISTICS MAY DIFFER, DEPENDING ON THE CABLE STRUCTURE. PLEASE CONFIRM BEFORE THE USE.

| 4 | POLYAMIDE | (BLACK) UL94V-0 | 9 | CHLOROPRENE RUBBER | (BLACK) |
|-----|-----------------|-------------------------------|-----|--------------------|----------------------------|
| 3 | BRASS | SILVER PLATING 2 μ m min. | 8 | BRASS | |
| 2 | STAINLESS STEEL | | 7 | STEEL | NICKEL PLATING M2.6×0.45×2 |
| 1 | ZINC ALLOY | MATTE FINISH NICKEL PLATED | 6 | BRASS | MATTE FINISH NICKEL PLATED |
| | | | 5 | BRASS | MATTE FINISH NICKEL PLATED |
| NO. | MATERIAL | FINISH, REMARKS | NO. | MATERIAL | FINISH, REMARKS |

| | | | | | | |
|-------------------------------|--|-------------------------------------|---|---------------------------------------|--|----------|
| CODE NO. (OLD) CL | | DRAWN <i>M. Sato</i> 17.03.06 | DESIGNED <i>T. Horii</i> 07.03.06 | CHECKED <i>M. Sato</i> 07.03.07 | APPROVED <i>M. Sato</i> 07.03.07 | RELEASED |
| DRAWING NO. EDC4-020545-73 | | PART NO. HR10A-7J-6P(73) | | | | |
| SCALE 2 : 1 | | CODE NO. CL110-0312-9-73 | | | | 1 1 |
| UNITS mm | | HRS HIROSE ELECTRIC CO., LTD. | | | | |

| |
|----|
| TO |
| R |
| |
| |

X-ON Electronics

Largest Supplier of Electrical and Electronic Components

Click to view similar products for [Circular Push Pull Connectors](#) category:

Click to view products by [Hirose](#) manufacturer:

Other Similar products are found below :

[6407-249V-11273P](#) [6408-201V-13273](#) [6408-202V-13343](#) [6408-202V-17343](#) [EZG.0B.309.CLN](#) [FFA.2S.310.ZLA](#) [FGA.1B.307.CYCD72Z](#)
[FGJ.1B.304.CLLD76](#) [FGJ.1B.306.CWLD72](#) [FGJ.2B.302.CYMD82Z](#) [FGJ.2B.310.CYMD72Z](#) [FGJ.3B.304.CYMD10Z](#)
[FGJ.3B.304.CYMD82Z](#) [FHJ.2B.310.CLLD72](#) [PCS.01.250.DLLE24](#) [PHG.0K.305.CYMC40Z](#) [PHG.1K.308.CLLK85](#) [PKG.M0.6BL.LZ](#)
[PLC.M1.0SL.LA](#) [GMA.10.290.DN](#) [GMA.3B.090.DA](#) [PRG.M0.6GL.LC52GZ](#) [PSA.1S.275.CTLC66](#) [ABF.1S.250.NTA](#) [133020F](#)
[1331ER193MZ](#) [1332M107MZ](#) [DTS26Z19-32JA-LC](#) [DTS26Z19-32SA](#) [DTS26Z19-32SA-LC](#) [DTS26Z23-55HA](#) [DTS26Z23-55HA-LC](#)
[DTS26Z23-55JA-LC](#) [EAJ.1B.306.CWA](#) [ECG.XB.312.CLL](#) [1589430-2](#) [EEA.0B.305.CLN](#) [EEA.0B.309.CLL](#) [ELF.00.250.NTL](#)
[ERA.01.250.DLL](#) [BRD.0B.200.PCSG](#) [BRR.2S.200.PZVG](#) [HR10A-P](#) [CAH.M34.SLL.C72GZ](#) [CAJ.M34.SLL.C72GZ](#) [300500](#)
[ESB.00.303.NLL](#) [EXG.0B.309.HLN](#) [FFB.1S.250.CLAC27](#) [FFG.1B.306.CLAZ](#)