

Push-Pull Connectors

HR10 Series



■ Overview

The HR10 series connectors are push-pull coupling type micro-connectors. They have been developed in response to customers' needs for miniaturization, high density, and easy handling. The HR10 series connectors offer light weight and assure high reliability and durability as well as easy "push-pull" operation.

You may apply the HR10 series connectors to all kinds of small-sized electronic equipment requiring high reliability. However, these simple but refined connectors are most suitable for portable electronic equipment which requires good appearance.

■ Features

1. "A LITTLE GIANT"

The most compact HR10 series is as slender as a cigarette but it fits every application with well-balanced, simplified layout in limited space.

2. Easy "PUSH-PULL" OPERATION

One touch "push-pull" coupling mechanism assures easy and quick connecting and disconnecting. You can couple it accurately just by pushing any part of the connector housing.

3. Polarization

Five-key system permits only one way of coupling so that you can find right position to connect even when blind mating.

4. Protection of connection pin

A connector pin is located to avoid any damage which may be caused when blind mating.

5. High density

The space-saving "push-pull" mechanism facilitates multi-installation of connectors.

6. Easy wiring and mounting

No use of screws makes wiring and mounting easier.

7. Simple and refined appearance

Simple and well designed connectors with matte finish enhance the appearance of the equipment.

■ Materials

Part	Material	Finish
Shell	Zinc alloy and Brass	Satin-finished nickel plate
Insulator	Polyamide / PBT	(Blue or Black)
Male terminal	Brass / Bronze	Silver or Gold plating
Female terminal	Beryllium / Phosphor bronze	Silver or Gold plating

■ Ordering information

HR10 **A** - **7** **P** - **4** **P** **A** (**)

①
②
③
④
⑤
⑥
⑦
⑧

① Series name: HR10 Series	④ Shell type P: Plug J: Jack R: Receptacle
② Type A: Low-cost model G: Shielded E: Built-in capacitor B: Coaxial terminal D: Connector sleeve rotation inhibited	⑤ Number of contacts
	⑥ Type of terminal P: Male terminal S: Female terminal
③ Shell size: Plug mating part outside diameter in mm	⑦ Terminal form C: Crimp connection system
	⑧ Other specifications: 2 numerical digits will be added when there is a specifications change other than shown in positions ① to ⑦

HR10 type

■ Plug



HR10-7P-6P(73)



HR10-10P-12P(73)

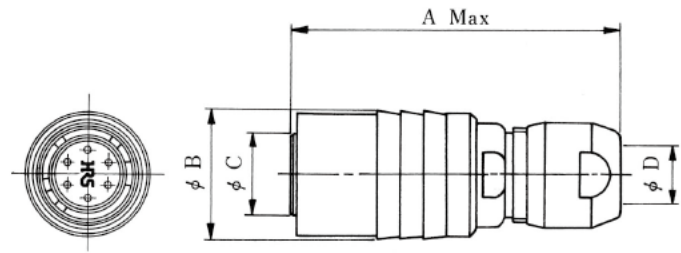

(An example in shape)

Unit : mm

HRS No.	Part No.	No. of pins	A	ϕB	ϕC	ϕD	Weight
110-0021-6-73	HR10-7P-4P(73)	4	28.5	11	7	5.2	8g
110-0022-9-73	HR10-7P-4S(73)	4	28.5	11	7	5.2	8g
110-0023-1-73	HR10-7P-6P(73)	6	28.5	11	7	5.2	8g
110-0024-4-73	HR10-7P-6S(73)	6	28.5	11	7	5.2	8g
110-0025-7-73	HR10-10P-12P(73)	12	32.5	14	9.5	7.2	15g
110-0026-0-73	HR10-10P-12S(73)	12	32.5	14	9.5	7.2	15g

■ Receptacle



HR10-7R-6S(73)



HR10-10R-12S(73)

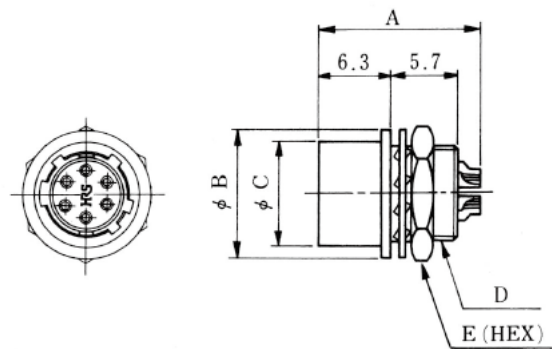

(An example in shape)

Unit : mm

HRS No.	Part No.	No. of pins	A	ϕB	ϕC	D	E	Weight
110-0031-0-73	HR10-7R-4S(73)	4	14	11	8.85	M8×0.5	10	3.5g
110-0032-2-73	HR10-7R-4P(73)	4	14	11	8.85	M8×0.5	10	3.5g
110-0033-5-73	HR10-7R-6S(73)	6	14	11	8.85	M8×0.5	10	3.5g
110-0034-8-73	HR10-7R-6P(73)	6	14	11	8.85	M8×0.5	10	3.5g
110-0035-0-73	HR10-10R-12S(73)	12	16	14	11.9	M11×0.75	13	6g
110-0036-3-73	HR10-10R-12P(73)	12	16	14	11.9	M11×0.75	13	6g

Remarks : For mounting holes, see page 198.

■ Plug (PCB dip type)

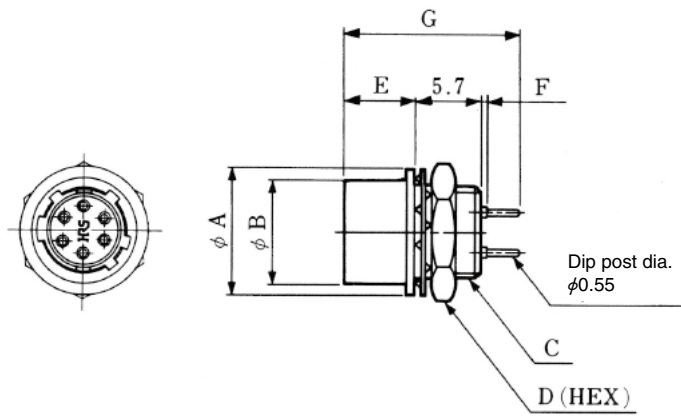

(An example in shape)

Unit : mm

HRS No.	Part No.	No.of pins	ϕA	ϕB	C	D	E	F	G	Weight
110-0059-9-73	HR10-7R-4SA(73)	4	11	8.85	M8×0.5	10	6.3	0.5	15.5	3g
110-0050-4-73	HR10-7R-6SA(73)	6	11	8.85	M8×0.5	10	6.3	0.5	15.5	3g
110-0061-0-73	HR10-7R-6PA(73)	6	11	8.85	M8×0.5	10	6.3	0.5	15.5	3g
110-0049-5-73	HR10-10R-12SA(73)	12	14	11.9	M11×0.75	13	6.3	0.5	15.5	5g
110-0055-8-73	HR10-10R-12PA(73)	12	14	11.9	M11×0.75	13	6.3	0.5	15.5	5g

Remarks : 1.For mounting holes, see page 198.
 2.For dip post arrangement, see page 193.

■ Jack

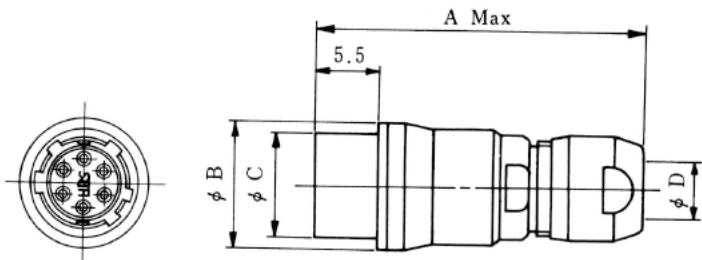

Unit : mm

HRS No.	Part No.	No.of pins	A	ϕB	ϕC	D	Weight
110-0027-2-73	HR10-7J-4S(73)	4	28.5	11	8.85	5.2	7g
110-0028-5-73	HR10-7J-4P(73)	4	28.5	11	8.85	5.2	7g
110-0029-8-73	HR10-7J-6S(73)	6	28.5	11	8.85	5.2	7g
110-0030-7-73	HR10-7J-6P(73)	6	28.5	11	8.85	5.2	7g
110-0037-6-73	HR10-10J-12S(73)	12	32.5	14	11.9	7.2	14g
110-0038-9-73	HR10-10J-12P(73)	12	32.5	14	11.9	7.2	14g

HR10A·10G Type

■ Plug (Solder type)



HR10A-7P-6P(73)

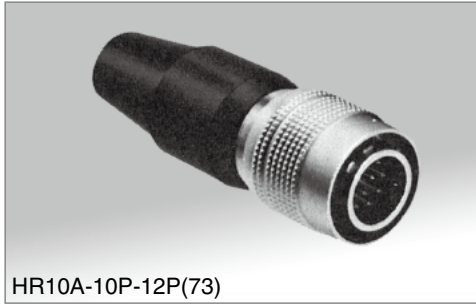

HR10A-10P-12P(73)

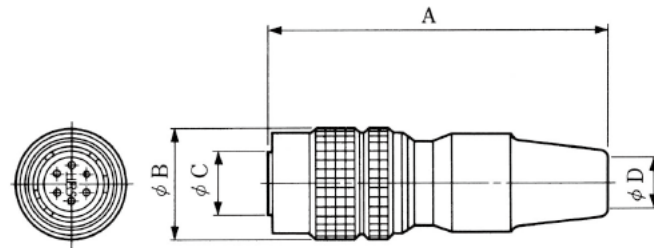

(An example in shape)

Unit : mm

HRS No.	Part No.	No.of pins	A	φB	φC	φD	Weight
110-0301-2-73	HR10A-7P-4P(73)	4	35	11.5	7	5	9g
110-0302-5-73	HR10A-7P-4S(73)	4	35	11.5	7	5	9g
110-0318-5-73	HR10A-7P-5P(73)	5	35	11.5	7	5	9g
110-0319-8-73	HR10A-7P-5S(73)	5	35	11.5	7	5	9g
110-0303-8-73	HR10A-7P-6P(73)	6	35	11.5	7	5	9g
110-0304-0-73	HR10A-7P-6S(73)	6	35	11.5	7	5	9g
110-0407-3-73	HR10A-10P-10P(73)	10	43	14.7	9.5	7	16g
110-0408-6-73	HR10A-10P-10S(73)	10	43	14.7	9.5	7	16g
110-0401-7-73	HR10A-10P-12P(73)	12	43	14.7	9.5	7	16g
110-0402-0-73	HR10A-10P-12S(73)	12	43	14.7	9.5	7	16g
110-0713-0-73	HR10A-13P-20P(73)	20	58.8	19	13	7	37g
110-0716-8-73	HR10A-13P-20S(73)	20	58.8	19	13	7	37g

■ Plug (Crimp type)



HR10A-7P-6PC(73)



HR10A-10P-12PC(73)

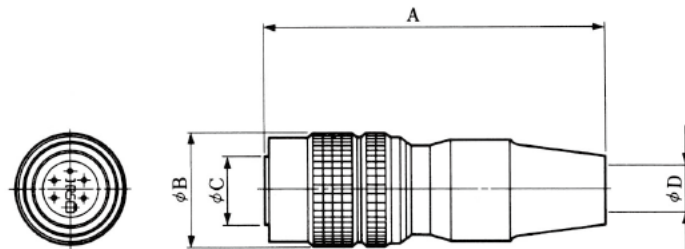

(An example in shape)

Unit : mm

HRS No.	Part No.	No.of pins	A	φB	φC	φD	Weight
110-0501-1-73	HR10A-7P-4PC(73)	4	35	11.5	7	5	9g
110-0502-4-73	HR10A-7P-4SC(73)	4	35	11.5	7	5	9g
110-0503-7-73	HR10A-7P-6PC(73)	6	35	11.5	7	5	9g
110-0504-0-73	HR10A-7P-6SC(73)	6	35	11.5	7	5	9g
110-0601-6-73	HR10A-10P-10PC(73)	10	43	14.7	9.5	7	16g
110-0602-9-73	HR10A-10P-10SC(73)	10	43	14.7	9.5	7	16g
110-0603-1-73	HR10A-10P-12PC(73)	12	43	14.7	9.5	7	16g
110-0604-4-73	HR10A-10P-12SC(73)	12	43	14.7	9.5	7	16g
110-0701-0-73	HR10A-13P-20PC(73)	20	58.8	19	13	7	37g
110-0702-3-73	HR10A-13P-20SC(73)	20	58.8	19	13	7	37g

HR10 Series Push-Pull Connectors

■Receptacle (Solder type)

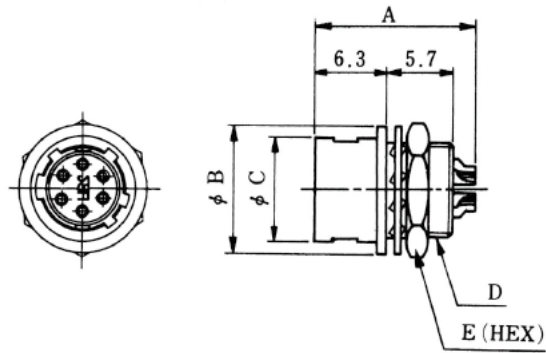
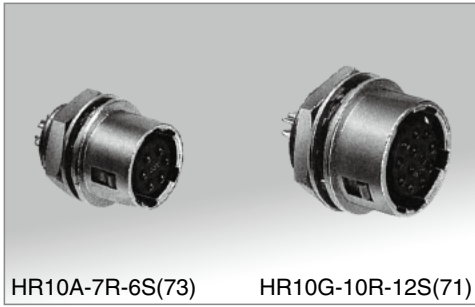

(An example in shape)

Unit : mm

HRS No.	Part No.	No. of pins	A	φB	φC	D	E	Weight
110-0305-3-73	HR10A-7R-4S(73)	4	14	11	8.85	M8x0.5	10	3g
110-0306-6-73	HR10A-7R-4P(73)	4	14	11	8.85	M8x0.5	10	3g
110-0320-7-73	HR10A-7R-5S(73)	5	14	11	8.85	M8x0.5	10	3g
110-0321-0-73	HR10A-7R-5P(73)	5	14	11	8.85	M8x0.5	10	3g
110-0307-9-73	HR10A-7R-6S(73)	6	14	11	8.85	M8x0.5	10	3g
110-0308-1-73	HR10A-7R-6P(73)	6	14	11	8.85	M8x0.5	10	3g
110-0409-9-71	HR10A-10R-10S(71)	10	16	14	11.9	M11x0.75	13	5g
110-0410-8-73	HR10A-10R-10P(73)	10	16	14	11.9	M11x0.75	13	5g
110-0403-2-71	HR10A-10R-12S(71)	12	16	14	11.9	M11x0.75	13	5g
110-0404-5-73	HR10A-10R-12P(73)	12	16	14	11.9	M11x0.75	13	5g
110-0714-2-73	HR10A-13R-20S(73)	20	19.2	18	15.4	M14x0.75	17	8g
110-0715-5-73	HR10A-13R-20P(73)	20	20.2	18	15.4	M14x0.75	17	8g

HRS No.	Part No.	No. of pins	A	φB	φC	D	E	Weight	Remarks
110-1601-1-73	HR10G-7R-4S(73)	4	14	11	8.85	M8x0.5	10	3g	Shield type
110-1602-4-73	HR10G-7R-4P(73)	4	14	11	8.85	M8x0.5	10	3g	
110-1605-2-73	HR10G-7R-6S(73)	6	14	11	8.85	M8x0.5	10	3g	
110-1606-5-73	HR10G-7R-6P(73)	6	14	11	8.85	M8x0.5	10	3g	
110-1607-8-71	HR10G-10R-10S(71)	10	16	14	11.9	M11x0.75	13	5g	
110-1608-0-73	HR10G-10R-10P(73)	10	16	14	11.9	M11x0.75	13	5g	
110-1609-3-71	HR10G-10R-12S(71)	12	16	14	11.9	M11x0.75	13	5g	
110-1610-2-73	HR10G-10R-12P(73)	12	16	14	11.9	M11x0.75	13	5g	

■Receptacle (Crimp type)

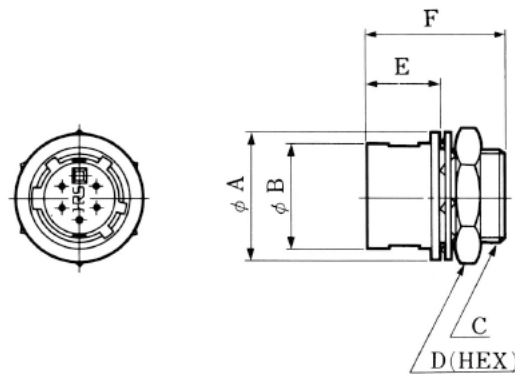
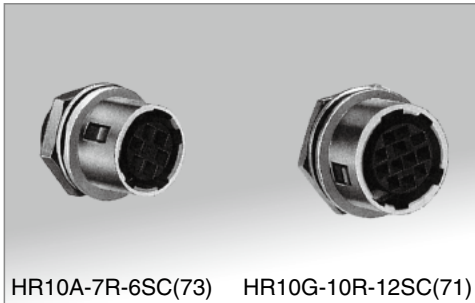

(An example in shape)

Unit : mm

HRS No.	Part No.	No. of pins	A	φB	C	D	E	F	Weight
110-0506-5-73	HR10A-7R-4SC(73)	4	11	8.85	M8x0.5	10	6.3	12	3g
110-0505-2-73	HR10A-7R-4PC(73)	4	11	8.85	M8x0.5	10	6.3	12.2	3g
110-0508-0-73	HR10A-7R-6SC(73)	6	11	8.85	M8x0.5	10	6.3	12	3g
110-0507-8-73	HR10A-7R-6PC(73)	6	11	8.85	M8x0.5	10	6.3	12.2	3g
110-0606-0-71	HR10A-10R-10SC(71)	10	14	11.9	M11x0.75	13	6.3	12	5g
110-0605-7-71	HR10A-10R-10PC(71)	10	14	11.9	M11x0.75	13	6.3	12.2	5g
110-0608-5-71	HR10A-10R-12SC(71)	12	14	11.9	M11x0.75	13	6.3	12	5g
110-0607-2-71	HR10A-10R-12PC(71)	12	14	11.9	M11x0.75	13	6.3	12.2	5g
110-0703-6-73	HR10A-13R-20SC(73)	20	18	15.4	M14x0.75	17	9.3	15	8g
110-0704-9-73	HR10A-13R-20PC(73)	20	18	15.4	M14x0.75	17	9.3	15	8g

HRS No.	Part No.	No. of pins	A	φB	C	D	E	F	Weight	Remarks
110-1701-6-73	HR10G-7R-4SC(73)	4	11	8.85	M8x0.5	10	6.3	12	3g	Shield type
110-1702-9-73	HR10G-7R-4PC(73)	4	11	8.85	M8x0.5	10	6.3	12.2	3g	
110-1705-7-73	HR10G-7R-6SC(73)	6	11	8.85	M8x0.5	10	6.3	12	3g	
110-1706-0-73	HR10G-7R-6PC(73)	6	11	8.85	M8x0.5	10	6.3	12.2	3g	
110-1707-2-71	HR10G-10R-10SC(71)	10	14	11.9	M11x0.75	13	6.3	12	5g	
110-1708-5-71	HR10G-10R-10PC(71)	10	14	11.9	M11x0.75	13	6.3	12.2	5g	
110-1709-8-71	HR10G-10R-12SC(71)	12	14	11.9	M11x0.75	13	6.3	12	5g	
110-1710-7-73	HR10G-10R-12PC(73)	12	14	11.9	M11x0.75	13	6.3	12.2	5g	
110-1711-0-73	HR10G-13R-20SC(73)	20	18	15.4	M14x0.75	17	9.3	15	8g	
110-1712-2-73	HR10G-13R-20PC(73)	20	18	15.4	M14x0.75	17	9.3	15	8g	

■ Receptacle (Dip type)

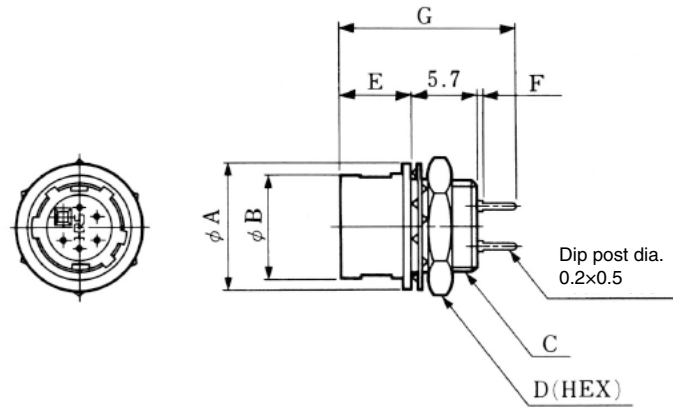
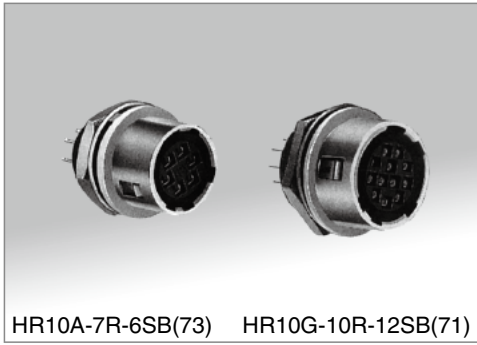

(An example in shape)

Unit : mm

HRS No.	Part No.	No. of pins	φA	φB	C	D	E	F	G	Weight	Remarks
110-0314-4-73	HR10A-7R-4SB(73)	4	11	8.85	M8×0.5	10	6.3	0.5	15.6	3g	Shield type
110-0315-7-73	HR10A-7R-4PB(73)	4	11	8.85	M8×0.5	10	6.3	0.5	15.6	3g	
110-0322-2-73	HR10A-7R-5SB(73)	5	11	8.85	M8×0.5	10	6.3	0.5	15.6	3g	
110-0316-0-73	HR10A-7R-6SB(73)	6	11	8.85	M8×0.5	10	6.3	0.5	15.6	3g	
110-0317-2-73	HR10A-7R-6PB(73)	6	11	8.85	M8×0.5	10	6.3	0.5	15.6	3g	
110-0413-6-71	HR10A-10R-10SB(71)	10	14	11.9	M11×0.75	13	6.3	0.5	15.6	5g	
110-0414-9-71	HR10A-10R-10PB(71)	10	14	11.9	M11×0.75	13	6.3	0.5	15.6	5g	
110-0415-1-71	HR10A-10R-12SB(71)	12	14	11.9	M11×0.75	13	6.3	0.5	15.6	5g	
110-0416-4-71	HR10A-10R-12PB(71)	12	14	11.9	M11×0.75	13	6.3	0.5	15.6	5g	
110-0707-7-73	HR10A-13R-20SB(73)	20	18	15.4	M14×0.75	17	9.3	0	17.8	8g	
110-0708-0-73	HR10A-13R-20PB(73)	20	18	15.4	M14×0.75	17	9.3	0	17.8	8g	
110-1801-0-73	HR10G-7R-4SB(73)	4	11	8.85	M8×0.5	10	6.3	0.5	15.6	3g	
110-1802-3-73	HR10G-7R-4PB(73)	4	11	8.85	M8×0.5	10	6.3	0.5	15.6	3g	
110-1805-1-73	HR10G-7R-6SB(73)	6	11	8.85	M8×0.5	10	6.3	0.5	15.6	3g	
110-1806-4-73	HR10G-7R-6PB(73)	6	11	8.85	M8×0.5	10	6.3	0.5	15.6	3g	
110-1807-7-71	HR10G-10R-10SB(71)	10	14	11.9	M11×0.75	13	6.3	0.5	15.6	5g	
110-1808-0-71	HR10G-10R-10PB(71)	10	14	11.9	M11×0.75	13	6.3	0.5	15.6	5g	
110-1809-2-71	HR10G-10R-12SB(71)	12	14	11.9	M11×0.75	13	6.3	0.5	15.6	5g	
110-1810-1-71	HR10G-10R-12PB(71)	12	14	11.9	M11×0.75	13	6.3	0.5	15.6	5g	
110-1811-4-73	HR10G-13R-20SB(73)	20	18	15.4	M14×0.75	17	9.3	0	17.8	8g	
110-1812-7-73	HR10G-13R-20PB(73)	20	18	15.4	M14×0.75	17	9.3	0	17.8	8g	

Remarks : 1. For mounting holes, see page 198.
2. For dip post arrangement, see page 193.

■ Dust cap

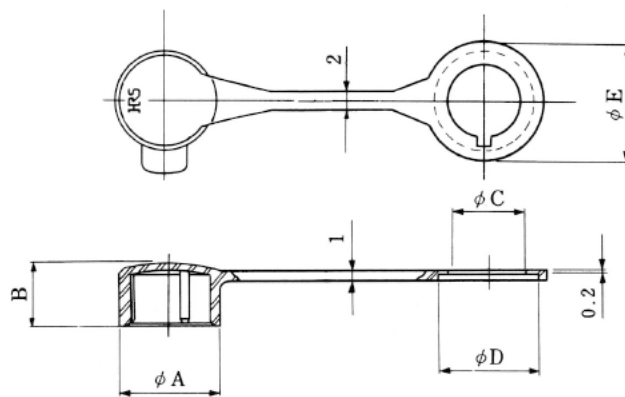
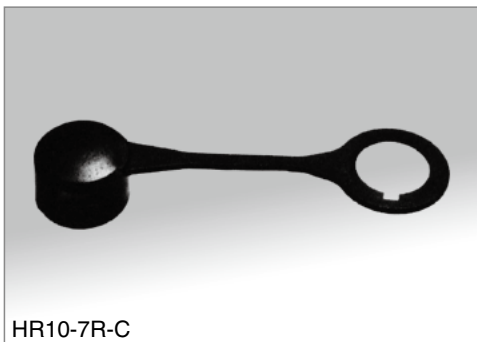

(An example in shape)

Unit : mm

HRS No.	Part No.	φA	B	φC	φD	φE
110-0058-6-00	HR10-7R-C	11	7	8	11.2	13
110-0052-0-00	HR10-10R-C	14	8.5	10.8	14	15
110-0452-8-00	HR10A-13R-C	17.5	11.5	14	18.1	19

HR10 Series ● Push-Pull Connectors

■ Jack (Solder type)

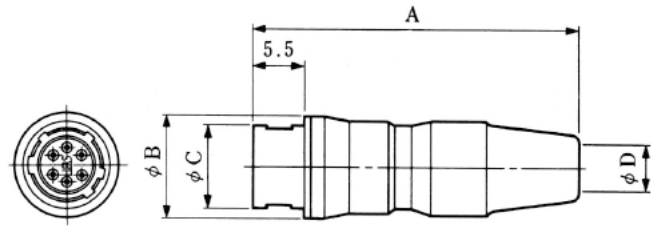
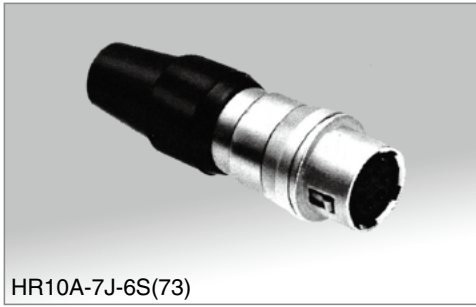

(An example in shape)

Unit : mm



HRS No.	Part No.	No. of pins	A	φB	φC	φD	Weight
110-0309-4-73	HR10A-7J-4S(73)	4	35.3	11	8.85	5.5	9g
110-0310-3-73	HR10A-7J-4P(73)	4	35.3	11	8.85	5.5	9g
110-0311-6-73	HR10A-7J-6S(73)	6	35.3	11	8.85	5.5	9g
110-0312-9-73	HR10A-7J-6P(73)	6	35.3	11	8.85	5.5	9g
110-0411-0-73	HR10A-10J-10S(73)	10	43	14	11.9	7	16g
110-0412-3-73	HR10A-10J-10P(73)	10	43	14	11.9	7	16g
110-0405-8-73	HR10A-10J-12S(73)	12	43	14	11.9	7	16g
110-0406-0-73	HR10A-10J-12P(73)	12	43	14	11.9	7	16g

■ Jack (Crimp type)

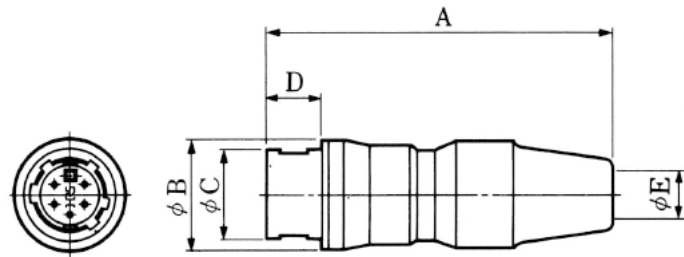

(An example in shape)

Unit : mm

HRS No.	Part No.	No. of pins	A	φB	φC	φD	Weight
110-0510-2-73	HR10A-7J-4SC(73)	4	35.3	11	8.85	5.5	9g
110-0512-8-73	HR10A-7J-6SC(73)	6	35.3	11	8.85	5.5	9g
110-0610-7-73	HR10A-10J-10SC(73)	10	43	14	11.9	5.5	16g
110-0612-2-73	HR10A-10J-12SC(73)	12	43	14	11.9	5.5	16g
110-0705-1-73	HR10A-13J-20SC(73)	20	58.5	18	15.4	8.5	37g
110-0706-4-73	HR10A-13J-20PC(73)	20	58.5	18	15.4	8.5	37g

HR10B Type Connector

The HR10B connector combines 10 signal lines and one coaxial contact in the standard number 10 shell. Electrical performance are same as HR10A connector except coaxial contacts. Performance specifications for the coaxial contacts are on the next page.

■ Plug



HR10B-10P-10PC(73)

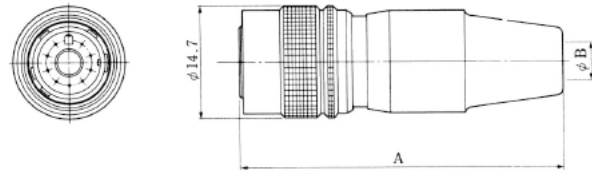

(An example in shape)

Unit : mm

HRS No.	Part No.	A	φB	Applicable coaxial contact
110-0901-0-73	HR10B-10P-10PC(73)	50	5	HR10B-2.5CJ(73)
110-0906-3-73	HR10B-10PA-10PC(73)	43	7	HR10B-2.5CJ(73)

■ Receptacle

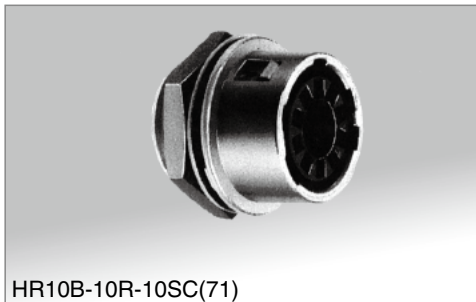

HR10B-10R-10SC(71)

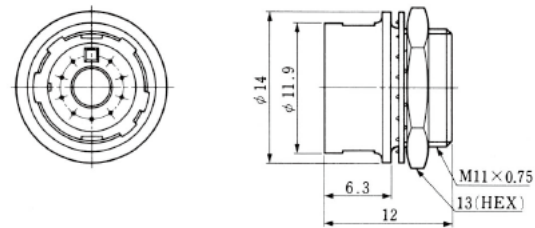

Unit : mm

HRS No.	Part No.	Applicable coaxial contact
110-0902-2-71	HR10B-10R-10SC(71)	HR10B-2.5CP(73)

Remarks : For mounting holes, see page 198.

■Coaxial contacts

The coaxial contacts shown here are for use with the HR10B connector. These contacts have locking barbs and are inserted from the rear of connector. Please use the following information to select the correct terminals.

■Material

Part	Material	Finish
Plug shell	Brass	Gold plating
Jack shell	Brass	Gold plating
Insulator	Tetrafluoride resin	
Male pin	Phosphor bronze	Gold plating
Female pin	Beryllium copper	Gold plating

■Performance

Description	Test data
Impedance	50Ω
Insulation resistance	1000MΩ or more at DC250V
Contact resistance	Center 6.5mΩ or less and outer 4mΩ or less at DC1A
Withstanding voltage	AC250V r.m.s for 1minute
V.S.W.R	1.3 or less for 0 to 1000MHz
Pull force	4.9N 500gf or more

■Plug

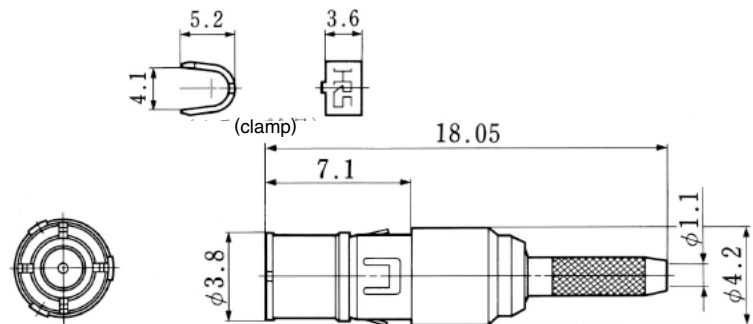

Unit : mm

HRS No.	Part No.	Applicable cable	Applicable connector
110-0904-8-73	HR10B-2.5CP(73)	0.8D-QEW-CW (By Fjikura wire)	HR10B-10R-10SC(71)

■Jack

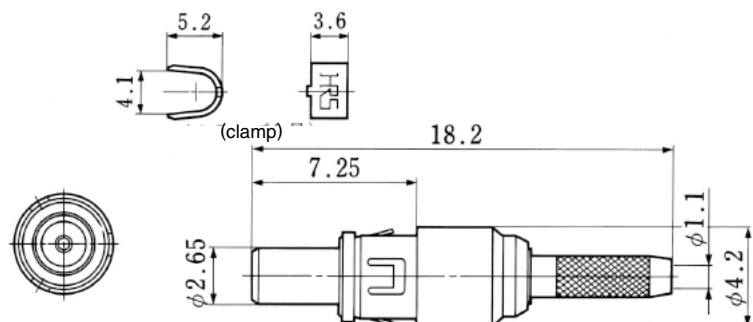
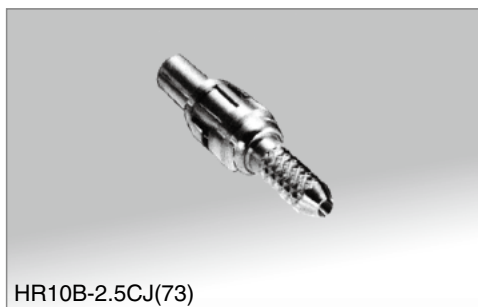

Unit : mm

HRS No.	Part No.	Applicable cable	Applicable connector
110-0903-5-73	HR10B-2.5CJ(73)	0.8D-QEW-CW (By Fjikura wire)	HR10B-10P-10PC(71)

■ Cable connecting methods

HR10B-2.5CP HR10B-2.5CJ

1. Cable end treatment

Fig.1

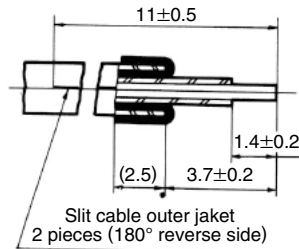

1. Dimensions for cable end treatment are shown in Fig 1.
2. Termination is described below.
 - (1). Strip cable outer jacket as indicated.
 - (2). Slit outer jacket on both sides per Fig.1.
 - (3). Fold back outer cover.
 - (4). Remove insulator from cable.

2. Soldering male pin to cable center conductor.

Fig.2

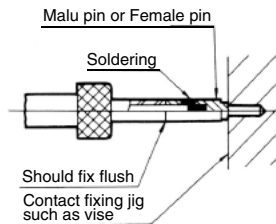

1. Solder male pin to cable center conductor as indicated in Fig.2.
 - (1). Pre-solder the solder pot of pin with $\phi 0.5$ mm string solder.
 - (2). Male pin should fit flush against the cable insulator as shown.
 - (3). Remove any excess solder from the pin with a knife. This surface must be smooth.
 - (4). A properly soldered terminal will yield 500gf when stretched.

3. Crimping cable outer conductor

Fig.3

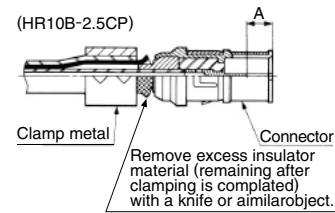

Table 1 dimension A

2.5CP	2.5CJ
1.5±0.2mm	0 ^{+0.3} ₀ mm

1. Insert cable prepared per PROCESS 2 into the connector. The cable should be inserted until it comes to a full stop. This may be verified by checking the dimension from the side of the connector to the top of the contact (as indicated in Fig 3). This dimension should be A.
2. Crimp this installed metal clamp with tool HR10-TC-01 per Fig.3 and remove excess insulation with a knife.

It is possible to pull back the contact. Hold cable when crimping metal clamp and keep the dimension to show in Fig 3. after crimping metal clamp.

HR10A-[]T Type (Threaded Coupling Type)

HR10A-()T connector is a new product having a threaded coupling locking mechanism. Electric performance is same as HR10 and HR10A push-pull locking type connector.

■ Plug (Solder type)



HR10A-10TP-12P(73)

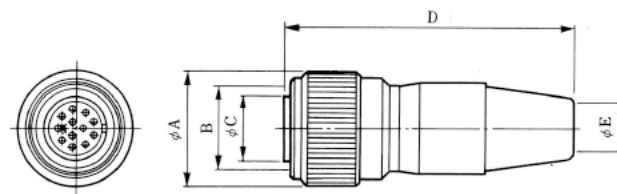

Unit : mm

HRS No.	Part No.	No.of pins	φA	B	φC	D	φE	Remarks
110-0331-3-73	HR10A-7TP-6P(73)	6	12	M10×0.75	7	M8×0.5	5	
110-0331-3-74	HR10A-7TP-6P(74)	6	12	M10×0.75	7	M8×0.5	5	Gold plating
110-0432-0-73	HR10A-10TP-12P(73)	12	17	M13×0.75	9.5	M8×0.5	7	
110-0446-5-73	HR10A-10TPA-12S(73)	12	17	M13×0.75	9.5	M8×0.5	7	
110-1101-9-73	HR10A-10WTP-12P(73)	12	15	M12×0.75	9.5	M11×0.75	6.5	*
110-1106-2-73	HR10A-10WTP-12S(73)	12	15	M12×0.75	9.5	M11×0.75	6.5	*
110-1015-9-73	HR10A-13TPD-20P(73)	20	20	M17×1	13	M11×0.75	7	

*Waterproof plug need resin filling inside when connector assembly.
When mated, the connector against water penetration.

■ Plug (Crimp type)



HR10A-10TP-12PC(73)

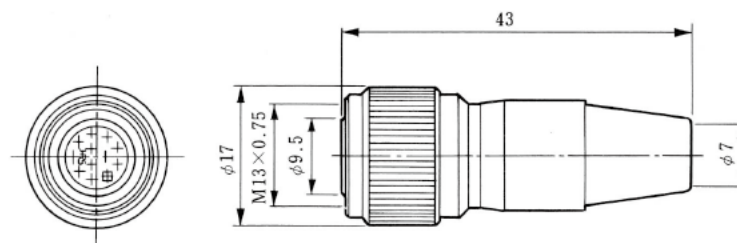

Unit : mm

HRS No.	Part No.	No.of pins
110-0455-6-73	HR10A-10TP-12PC(73)	12

■ Receptacle (Solder type)

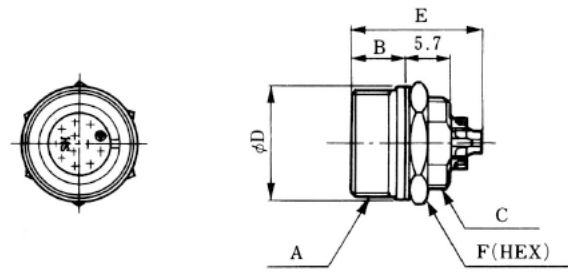

(An example in shape)

Unit : mm

HRS No.	Part No.	No.of pins	A	ϕB	C	ϕD	E	F	Remarks
110-0089-0-73	HR10-7TR-6S(73)	6	M10×0.75	6.3	M8×0.5	11	14	10	Gold plating
110-0453-0-73	HR10A-10TR-12S(73)	12	M13×0.75	6.3	M11×0.75	14	16	13	
110-1104-7-73	HR10A-10WTR-12S(73)	12	M12×0.75	6.8	M10.5×0.75	14	16	13	

Remarks: For mounting hole, see page 192(10TR,10WTR) 198(7TR)

■ Receptacle (Crimp type)

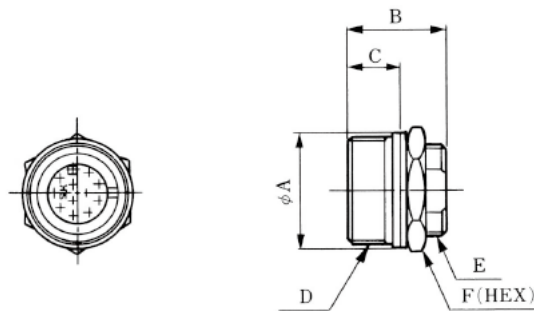

(An example in shape)

Unit : mm

HRS No.	Part No.	No.of pins	ϕA	B	C	ϕD	E	F
110-0456-9-73	HR10A-10TR-12SC(73)	12	14	12	6.3	M13×0.75	M11×0.75	13
110-1002-7-73	HR10A-13TR-20SC(73)	20	18	15	9.3	M17×1	M14×0.75	17

Remarks: For mounting hole, see page 192

■ Receptacle (Dip type)

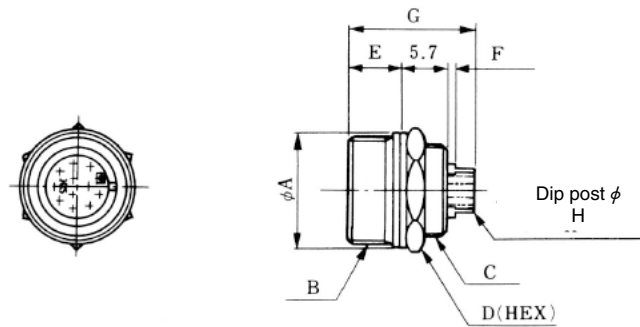

(An example in shape)

Unit : mm

HRS No.	Part No.	No.of pins	ϕA	B	C	D	E	F	E	H
110-0330-0-73	HR10A-7TR-6SA(73)	6	11	M10×0.75	M8×0.5	10	6.3	0.5	15.5	$\phi 0.55$
110-0433-3-73	HR10A-10TR-12SB(73)	12	14	M13×0.75	M11×0.75	13	6.3	0.5	15.5	0.2×0.5
110-0457-1-73	HR10A-10TR-12PB(73)	12	14	M13×0.75	M11×0.75	13	6.3	0.5	15.5	0.2×0.5
110-0445-2-73	HR10A-10TR-12PE(73)	12	14	M13×0.75	M11×0.75	13	6.3	0.5	14	0.2×0.5
110-1102-1-73	HR10A-10WTR-12SB(73)	12	14	M12×0.75	M10.5×0.75	13	6.8	0	15.5	0.2×0.5
110-1013-3-73	HR10A-13TR-20PB(73)	20	18	M17×1	M14×0.75	17	9.3	0	17.8	0.2×0.5
110-1014-6-73	HR10A-13TR-20SB(73)	20	18	M17×1	M14×0.75	17	9.3	0	17.8	0.2×0.5

Remarks : 1. For mounting holes, see page 192. However, 7TR size shell be referred to page 198 on the shell size 7.
2. For dip post arrangement, see page 193.

■ Jack (Solder type)



HR10A-10TJ-12S(73)

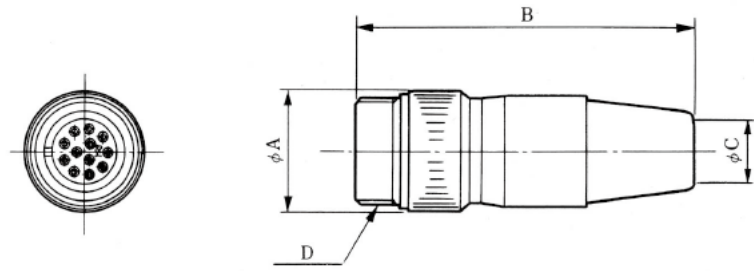

(An example in shape)

Unit : mm

HRS No.	Part No.	No. of pins	φA	B	φC	D	Remarks
110-0436-1-73	HR10A-10TJ-12S(73)	12	14.7	41.3	7	M13×0.75	
110-0459-7-73	HR10A-10TJ-12P(73)	12	14.7	41.3	7	M13×0.75	
110-1103-4-73	HR10A-10WTJ-12S(73)	12	14	46.5	6.5	M12×0.75	*

*Waterproof jack need resin filling inside when connector assembly.
When mated, the connector against water penetration.

■ Panel mounting hole dimensions (Screw coupling)

The mounting hole dimensions shown below are for connectors to be tightened by a hexagonal nut from the back of the panel. The dimensions below apply only to the HR10A-()T and not the 7TR. For the dimensions of connectors of other types, see page 198.

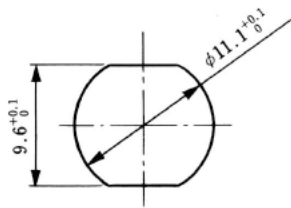

Type HR10A-10TR
(Panel thickness 1 to 2mm)

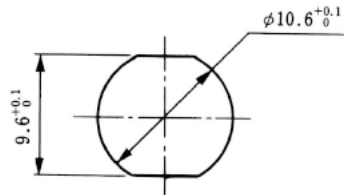

Type HR10A-10WTR
(Panel thickness 1 to 2mm)

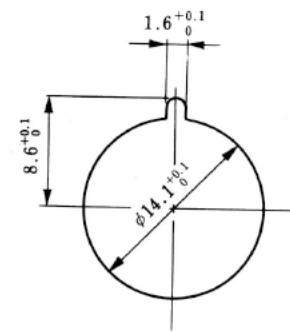

Type HR10A-13TR
(Panel thickness 1 to 1.5mm)

■ Contact

● Male pin

Unit : mm

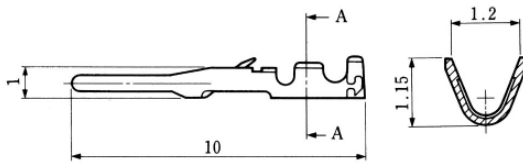

Type	HRS No.	Part No.	Type of plating	Applicable cable
Loose contact	110-0515-6	HR10-PC-111	Partial gold plating	AWG#26 to #30
	110-0513-0	HR10-PC-112	Silver plating	AWG#26 to #30
Chain contact	110-0516-9	HR10-PC-211	Partial gold plating	AWG#26 to #30
	110-0514-3	HR10-PC-212	Silver plating	AWG#26 to #30

Remarks : 1. Use cables with a coating outside diameter of 1mm or less.
2. Loose-picce terminal are available in packs. Each pack contains 100 terminals. Strip terminals are available in reels. Each reel contains 10,000 terminals.

● Female pin

Unit : mm

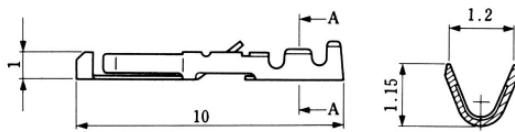

Type	HRS No.	Part No.	Type of plating	Applicable cable
Loose contact	112-0410-0	HR12-SC-111	Partial gold plating	AWG#26 to #30
	112-0411-3	HR12-SC-112	Silver plating	AWG#26 to #30
Chain contact	112-0407-6	HR12-SC-211	Partial gold plating	AWG#26 to #30
	112-0408-9	HR12-SC-212	Silver plating	AWG#26 to #30

Remarks : 1. Use cables with a coating outside diameter of 1mm or less.
2. Loose-picce terminal are available in packs. Each pack contains 100 terminals. Strip terminals are available in reels. Each reel contains 10,000 terminals.

■ Receptacle dip post arrangement dimensions

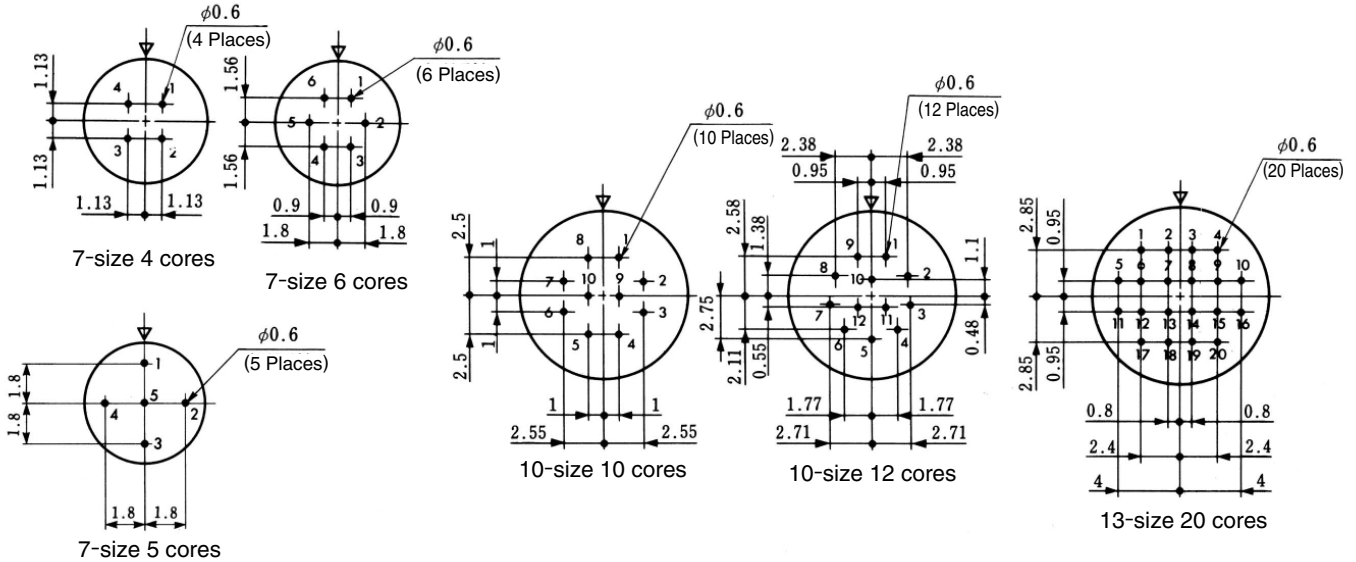

Remarks : 1. The above figures are views of receptacle-socket inserts from the mating side and plug-pin inserts from the wiring-connection side.
2. Dimensional tolerance of ± 0.05 is recommended for the board arrangement.

Tools

Type	Item	HRS No.	Part No.	Applicable terminal	Applicable cable
Manual	Manual crimping tool	150-0052-9	HR12-SC-TC	HR10-PC-112	AWG#26 to #30
				HR12-SC-112	
Automatic	Automatic crimping machine body	901-0005-4	CM-105	—	—
	Applicator	901-2015-9	AP105-HR12-1	HR10-PC-211 HR10-PC-212 HR10-SC-211 HR10-SC-212	AWG#26 to #30
Cable crimping tool		150-0036-2	HR10-TC-01	—	(HR10B-2.5CP, HR10B-2.5CJ)
		150-0041-2	HR10A-TC-02		$\phi 5, \phi 7$
Extractor		150-0050-3	HR12-SC-TP	HR12-SC-112 HR12-SC-212	—
		150-0039-0	RP6-SC-TP	HR10-PC-112 HR10-PC-212	
		150-0061-0	HR10B-TP	HR10B-2.5CP HR10B-2.5CJ	



(HR12-SC-TC)
Hand Crimp Tool



(HR12-SC-TP)

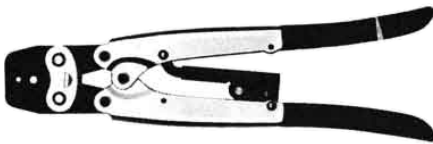

(HR10A-TC-02)
Hand Cable Crimp Tool



(RP6-SC-TP)
Extraction Tool

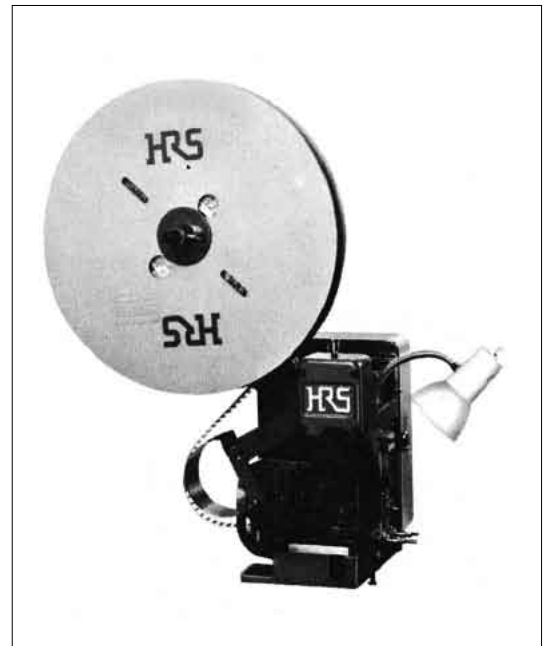

Auto Crimp Tool CM-105



(HR10B-TP)
Coaxial Contact Removal Tool

How to use a connector

	1. Inserting	2. Withdrawing
HR10 TYPE		
HR10A TYPE		
	<p>Hold the plug at point A, align the plug guide with the receptacle guide, and push the plug straight. The plug will mate with the receptacle smoothly.</p>	<p>Hold the plug connection sleeve B and pull the sleeve straight. The plug will come off easily.</p>

Jack (Solder type)

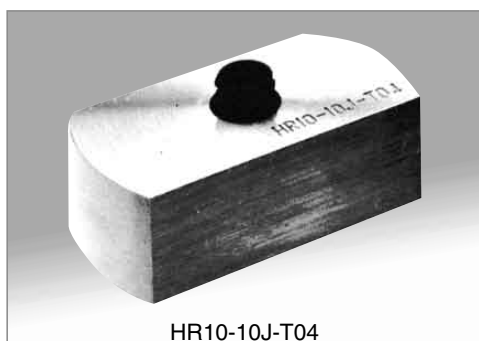
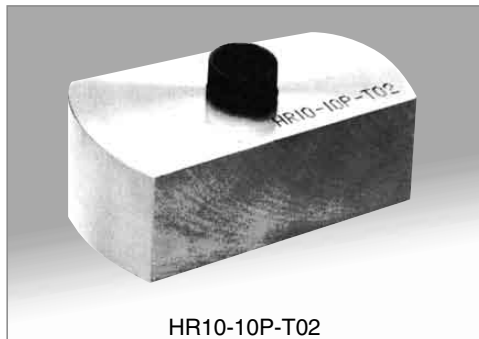

HRS No.	Part No.	Applicable connector
150-0009-0	HR10-7P-T01	HR10-7P
150-0010-9	HR10-10P-T02	HR10-10P
150-0011-1	HR10-7J-T03	HR10-7J
150-0012-4	HR10-10J-T04	HR10-10J
150-0059-8	HR10-13P-T05	HR10-13P
150-0060-7	HR10-13J-T06	HR10-13J

■ Connection work procedure(plug side)

This applies also to the jack side connection work.

No special connection work procedure is given here for the receptacle side because no special procedure is necessary.

HR10 TYPE

HR10A TYPE

Size	HR10	HR10A
Size 7	8	7.5
Size 10	11	9.5
Size 13	—	13

Size	Dimension C for HR10	Dimension D for HR10A	
		Solder type	Crimp type
Size 7	5.5 or less	10	15-20
Size 10	7 or less	16	15-20
Size 13	—	26	26

Size	Tightening force
Size 7	1.5N·m(15kg·cm)
Size 10	2N·m(20kg·cm)
Size 13	2N·m(20kg·cm)

	HR10 TYPE	HR10A TYPE
1	Use cables with a nominal sectional area of 0.129 mm ² (AWG#26) at the finish outside diameters applicable for each size.	
2	After processing the cable ends according to the dimensions in the above drawings, fit the parts to the cable as shown in the drawings.	
3	Fit the parts to the cable in the following order: tightener, clamp washer, and plug body.	Fit the parts to the cable in the following order: cord bushing and plug body.
4	(solder type) Insert the P shell unit into the assembly tool stand and solder it. (crimp type) After crimping the appropriate crimp terminal to the cable core, insert the crimp terminal into the terminal hole in the P shell unit.	
5	Assemble the connector in the following steps. 1.Screw the plug body into the thread in the P shell unit with the tightening force shown in Table 1 using a torque wrench with a fixed torque. Before tightening the plug body,slacken part C so that no load is applied to the soldered wires. 2.Apply the clamp washer to the bifurcated part of the plug body, and then tighten the tightener until surface B touches the plug body surface A.	1.Fix by caulking the clamp accompanying the cable with the cable crimping tool(HR10A-TC-02) 2.Screw the plug body into the thread in the P shell until with a tightening force shown in Table 1 using a torque wrench with a fixed torque. Before tightening the plug body, slacken the part D so that no load is applied to the soldered wires. 3.Tighten the set screw so that the tip of the screw presses one of the two bosses on the clamp. Fix the set screw with a tightening torque of 0.3N(3kg·cm) 4.Attach the cord bushing to the plug body.
6	This completes the work.	

For any question on using the plugs, contact our sales or engineering department.

Remarks : Loctite 242, Henkel Japan or equivalent is recommend to prevent the male thread section of the P shell unit and the set screw for loosening.

■ Connector

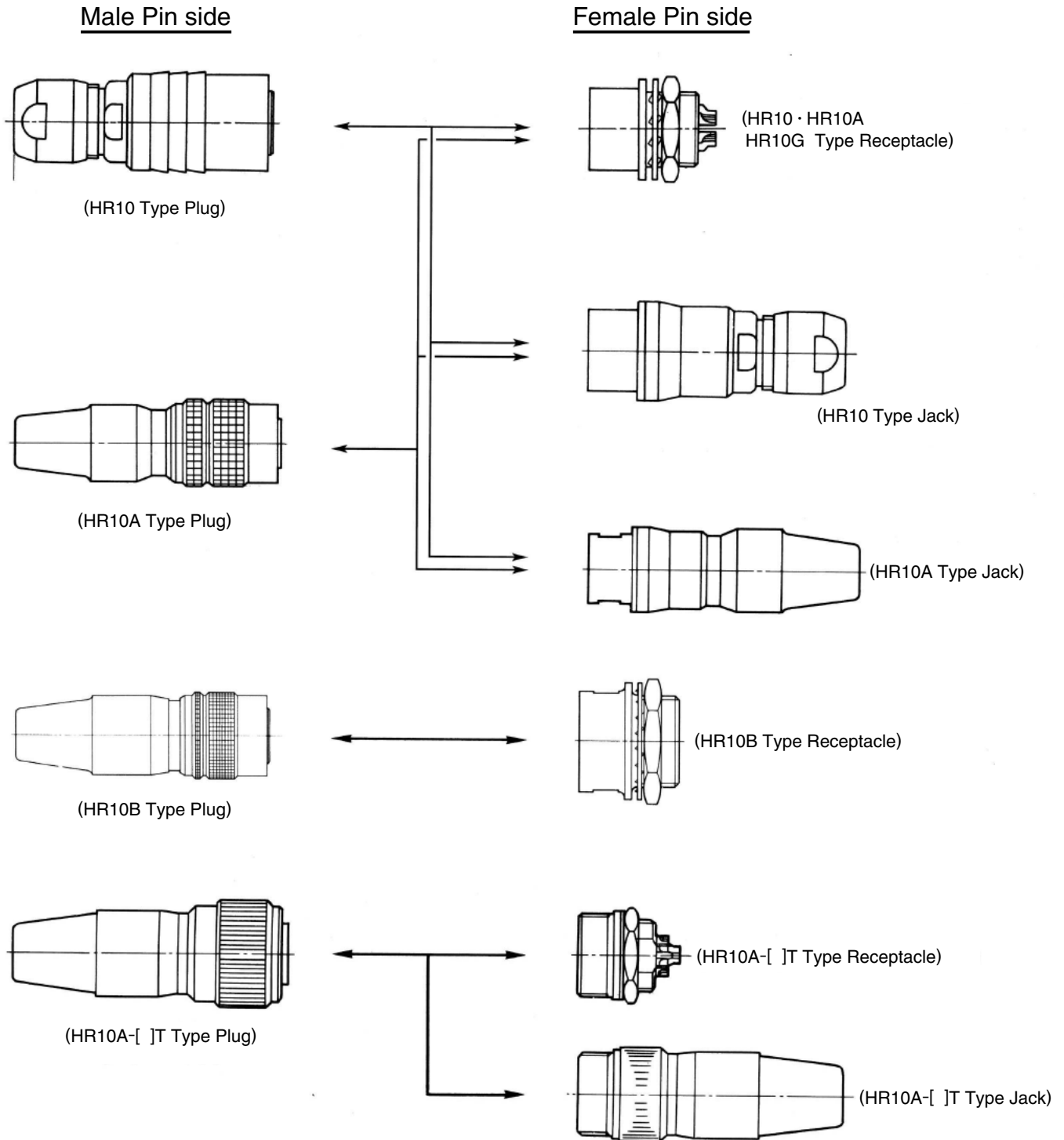

Notes

- 1 : When using a plug with male terminal, be sure to use a receptacle or jack fitted with female terminal.
- 2 : Standard finish of the terminal is gold plating for the HR10, and silver plating for the HR10A and HR10G.
Be sure to use male and female connectors of the same plating.

Recommended Mounting Hole

Mounting hole dimension shown here is tight by hexagon nut from back side.

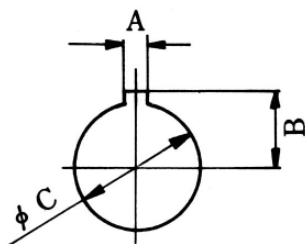

Shell size	7 size	10 size	13 size
Map mark			
A	1.6 ^{+0.1} ₀	2.6 ^{+0.1} ₀	2.6 ^{+0.1} ₀
B	5.1 ^{+0.1} ₀	6.6 ^{+0.1} ₀	8.6 ^{+0.1} ₀
C	8.1 ^{+0.1} ₀	11.1 ^{+0.1} ₀	14.5 ^{+0.1} ₀
Panel thickness	0.7~2	0.7~2	0.8~1.5

Contact arrangement

Shell size	7 size			10 size	
Contact arrangement					
No. of pins	4	5	6	10	12
Withstanding voltage	AC500V for a minute	AC300V for a minute		AC300V for a minute	
Current rating	2A	2A		2A	
Insulation resistance	MIN 1,000MΩ	MIN 1,000MΩ		MIN 1,000MΩ	
Contact resistance	MAX 10mΩ	MAX 10mΩ		MAX 10mΩ	
Solder pot inside dia.	φ0.8	φ0.8		φ0.8	

Shell size	10 size	13 size
Contact arrangement		
No. of pins	10+coaxial contact	20
Withstanding voltage	AC300V for a minute	AC300V for a minute
Current rating	2A	2A
Insulation resistance	MIN 1,000MΩ	MIN 1,000MΩ
Contact resistance	MAX 10mΩ	MAX 10mΩ
Solder pot inside dia.	-	φ0.8

Note 1. The contact arrangement shown here is the mating surface of socket insert assembled in a receptacle.

2. The withstanding voltage shown here is test voltage value.

3. The insulation resistance value is measured at DC100V.

4. The contact resistance value is measured at DC1A.

Precautions

1. Switch off the power of the circuit before disconnecting or plugging-in the connector.
2. Use a connector with socket contacts at the power side of the circuit.
3. Make sure that the coupling is in completely cocked position.
4. The cable pull and twisting strength and other characteristics may differ, depending on the cable structure. Please confirm before the use.

X-ON Electronics

Largest Supplier of Electrical and Electronic Components

Click to view similar products for [Circular Push Pull Connectors](#) category:

Click to view products by [Hirose](#) manufacturer:

Other Similar products are found below :

[6407-249V-11273P](#) [6408-201V-13273](#) [6408-202V-13343](#) [6408-202V-17343](#) [EZG.0B.309.CLN](#) [FFA.2S.310.ZLA](#) [FGA.1B.307.CYCD72Z](#)
[FGJ.1B.304.CLLD76](#) [FGJ.1B.306.CWLD72](#) [FGJ.3B.304.CYMD10Z](#) [FGJ.3B.304.CYMD82Z](#) [FHG.1B.303.CYCZ](#) [PCS.01.250.DLLE24](#)
[PHG.0K.305.CYMC40Z](#) [PHG.1K.308.CLLK85](#) [PKG.M0.6BL.LZ](#) [PLC.M1.0SL.LA](#) [GMA.10.290.DN](#) [GMA.3B.090.DA](#)
[PRG.M0.6GL.LC52GZ](#) [PSA.1S.275.CTLC66](#) [ABF.1S.250.NTA](#) [133020F](#) [1331ER193MZ](#) [1332M107MZ](#) [DTS26Z19-32JA-LC](#) [DTS26Z19-](#)
[32SA](#) [DTS26Z19-32SA-LC](#) [DTS26Z23-55HA](#) [DTS26Z23-55HA-LC](#) [EAJ.1B.306.CWA](#) [ECG.XB.312.CLL](#) [1589430-2](#) [EEA.0B.305.CLN](#)
[EEA.0B.309.CLL](#) [ELF.00.250.NTL](#) [ERA.01.250.DLL](#) [BRR.2S.200.PZVG](#) [HR10A-P](#) [CAH.M34.SLL.C72GZ](#) [CAJ.M34.SLL.C72GZ](#) [300500](#)
[ESB.00.303.NLL](#) [EXG.0B.309.HLN](#) [FFB.1S.250.CLAC27](#) [FGA.2B.306.CYCD92](#) [FGA.2B.306.CYCD92Z](#) [FGA.XB.312.CLAD72](#)
[FGJ.1B.302.CYMD62](#) [FGJ.3B.308.CLLD72Z](#)