

IX Series

IEC Standard Compliant Next-Generation Ethernet Connector for Industrial Equipment

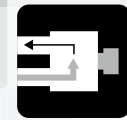

Contact Reliability



Rotary Attenuator



Click Feeling

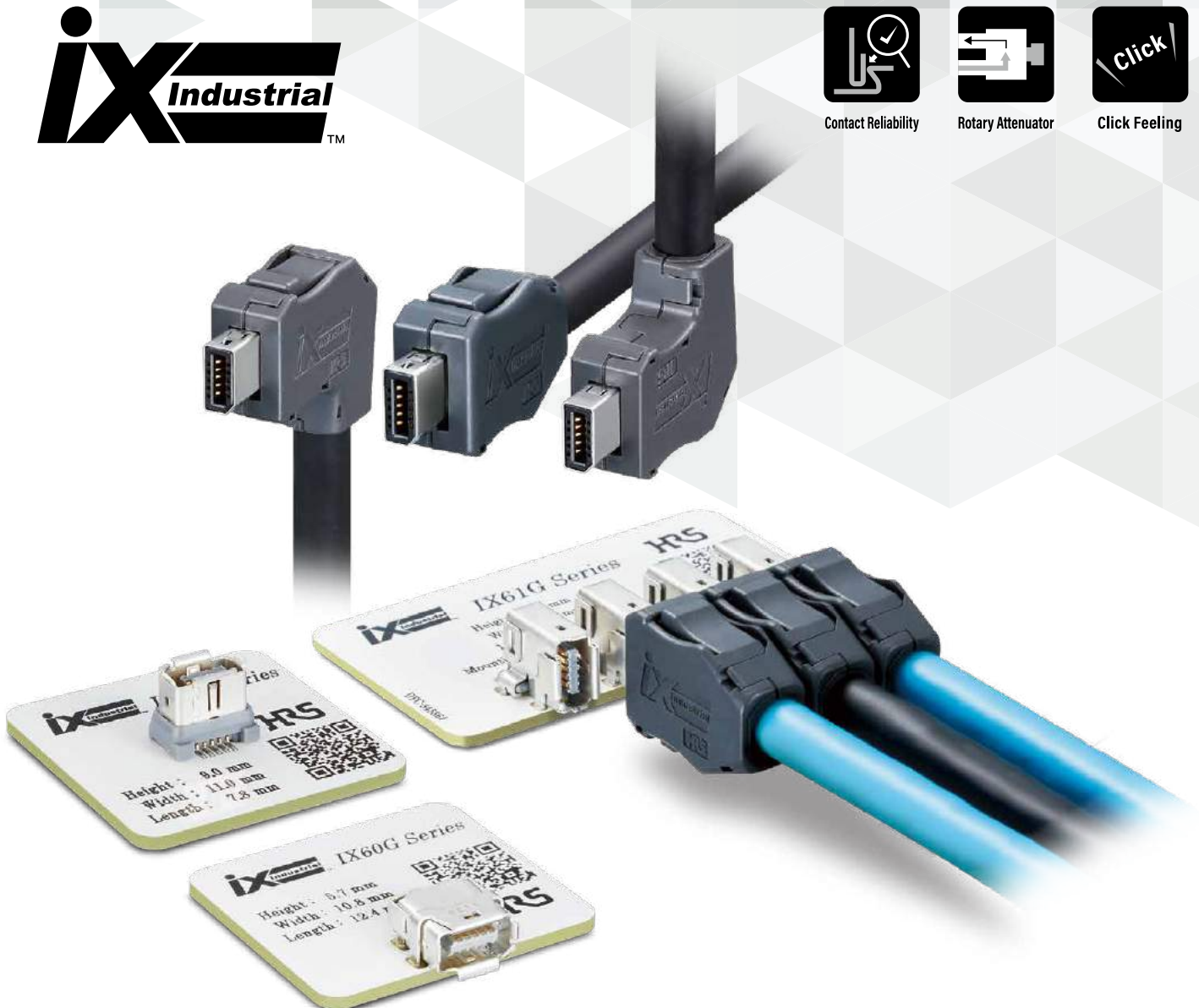

Product page
<https://www.hirose.com/product/en/products/IX/>



Special features page
https://www.hirose.com/product/en/pr/ix_industrial/ May 2021 ⑤

May.1.2022 Copyright 2022 HIROSE ELECTRIC CO., LTD. All Rights Reserved.

Advance with ix Industrial™

Overview

- Multi-purpose, compact I/O connector for industrial machinery.
- IEC Standard IEC 61076-3-124 compliant
- Compact, robust and supports high speeds
- High EMC resistance

Features

1. Contributes to Size Reduction

The ix Industrial™ offers a size reduction of 75% compared to conventional RJ45 modular solutions. The reduced mounting space enables a high degree of board design freedom. The ix Industrial™ also supports 10mm pitch parallel mounting.

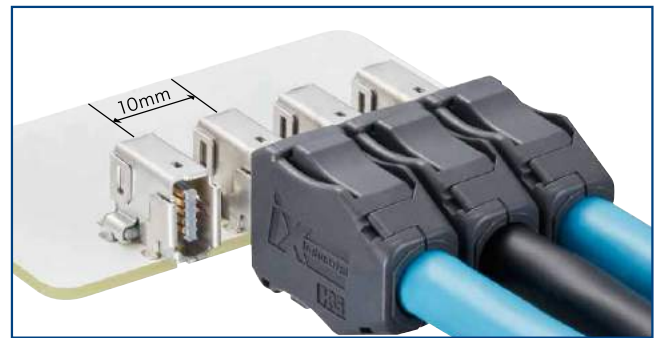
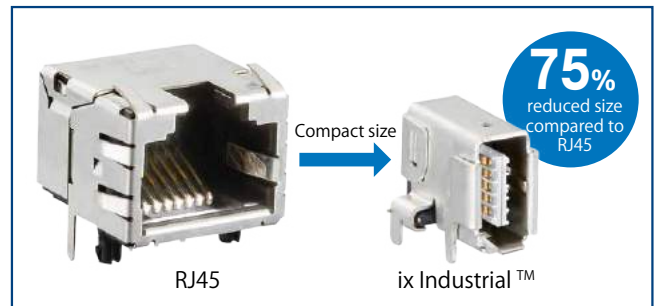

2. Single Action Lock Design

Locking is completed simply by inserting the plug into the receptacle. The audio click indicates mating completion. The lock can be released easily by pushing on the plug buttons while pulling out.

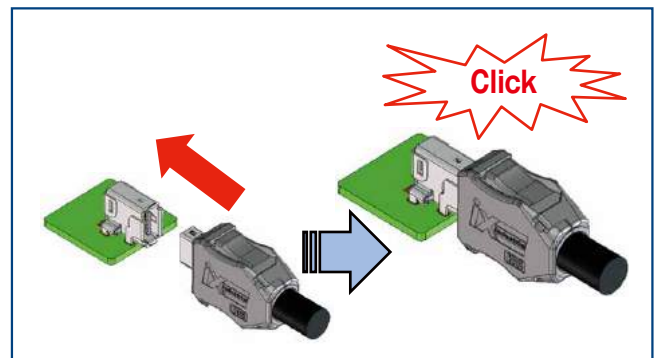

Single Action Lock for Easy Operation
Clear Tactile Click Prevents Incomplete Mating

3. Robust design resistant to prying

The PCB-mounted receptacle shell is designed to minimize the influence of prying forces from the plug side on the mated surface. Additionally, the through-holes prevent peeling of the mounted portion of the contact. Stainless steel is used to enhance the mechanical strength of the metal parts.

4. High EMC Resistance

The optimized shielding design guarantees high EMC resistance for secure data transmission.

5. High Speed Transmission

Supports Cat.5e (1Gbps) and Cat.6A(10Gbps) high speed Ethernet performance

6. THR (Through-Hole Mounting) Compatible

The receptacle shell is mounted in the through-holes for enhanced PCB mounting strength. THR mounting enables simultaneous reflow mounting with the signal contact SMT, for reduced board mounting time.

Product Specifications

Rated Current	All Pins	4 Pins : Pin No.1, 2, 6 and 7	Operating Temperature (Note 1)	-40 to +85°C
	1.5A	3A	Storage Temperature Range	-30 to +60°C
Rated Voltage	50V AC / 60V DC			

Item	Specification	Conditions
Contact Resistance	Signal : 30m Ω Max. (Note 2) Shield : 100m Ω Max. (Note 2)	Measured at 100mA
Insulation Resistance	500M Ω Min.	Measured at 500V DC
Withstanding Voltage	No flashover or breakdown	Voltage of 500V DC applied for 1 min.
Mating Durability	Signal : 80m Ω Max. (Note 2) Shield : 100m Ω Max. (Note 2)	5,000 insertion/extraction cycles
Vibration Resistance	No electrical discontinuity of 1 μ s Min. No damage, crack or loosened parts	10 to 500Hz, Half Amplitude 0.35mm, Acceleration of 50m/s ² .
Shock Resistance	No electrical discontinuity of 1 μ s Min. No damage, crack or loosened parts	300m/s ² , 11ms Duration, 3 Axis in Both Directions, 3 Times Each
Fretting Corrosion Resistance	No electrical discontinuity of 1 μ s Min. No damage, crack or loosened parts	490m/s ² , 30 times/min, 1000 times

Note 1 : Includes temperature rise due to current flow.
Note 2 : Conductor resistance of the cable is not included.

Materials / Finish

● Receptacle

Component	Materials	Color/Finish	Remarks
Insulator	Liquid Crystal Polymer	Gray	UL94V-0
Contact	Copper Alloy	Partially Gold Plated	-
Shielding Plate	Stainless Steel	-	-
Shell	Stainless Steel	Tin Plated	-
Suction Cap	Polyamide Resin	Black	UL94V-0

● Plug

Component	Material	Color/Finish	Remarks
Contact	Copper Alloy	Partially Gold Plated	-
Insulator	Polyamide Resin	Black, Dark Gray	UL94V-0
Shielding Plate	Stainless Steel	-	-
Insulator Case	Polyamide Resin	Black	UL94V-0
Guide	Polycarbonate Resin	Transparent, Transparent Yellow, Transparent Blue	UL94V-0
Shield Case	Stainless Steel	Nickel Plated	-
Shield Shell	Stainless Steel	Nickel Plated	-
Cover Case	Polycarbonate Resin	Dark Gray	UL94V-0

Product Number Structure

Refer to the chart below when determining the product specifications from the product number.
Please select from the product numbers listed in this catalog when placing orders.

■ Receptacle

IX 61 G - A - 10 P (##)

① ② ③ ④ ⑤ ⑥ ⑨

① Series Name	IX Series	④ Mating Key	A : Type A B : Type B
② Mounting/ Assembly Method	61 : Upright Right Angle SMT 60 : Right Angle SMT 80 : Vertical SMT	⑤ Maximum Number of Usable Positions	10 : 10pos. 8 : 8pos.
		⑥ Contact Gender	P : Male Contact S : Female Contact
③ Gigabit Ethernet Support	G	⑨ Plating Specifications	Blank : Gold Plated (01) : Palladium-Nickel Plated+Gold Plated

■ Plug

IX 40 G - A - 10 S - CV (7.0) (##)

① ② ③ ④ ⑤ ⑥ ⑦ ⑧ ⑨

① Series Name	IX Series	⑤ Maximum Number of Usable Positions	10 : 10pos. 8 (Note) : 8pos.
② Mounting/ Assembly Method	40 : Hand Solder 30 : IDC (26 to 28 AWG, Insulator Outer Diameter ϕ 0.95 to 1.05) 31 : IDC (24 to 25 AWG, Insulator Outer Diameter ϕ 1.1 to 1.25) 32 : IDC (22 AWG, Insulator Outer Diameter ϕ 1.4 to 1.6)	⑥ Contact Gender	P : Male Contact S : Female Contact
		⑦ Plug Cover Cabling Direction	CV : Straight CVL1 : Downward Cabling CVL2 : Upward Cabling
③ Gigabit Ethernet Support	G	⑧ Applicable Cable Diameter	(7.0) : Sheath Outer Diameter ϕ 6.3 to 7.2
④ Mating Key	A : Type A B : Type B	⑨ Plating Specifications	Blank : Gold Plated (01) : Palladium-Nickel Plated+Gold Plated

Note : Contacts No.3 and 8 do not have a hole to pass the wire through the IDC guide.

Connector Mating Combination Diagram

● Receptacle

● Plug

Upward Right Angle

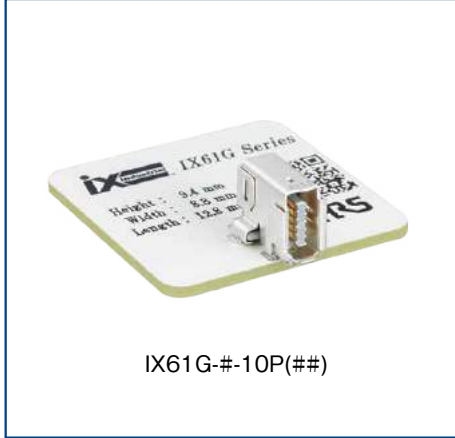

Straight



Right Angle



Right Angle, Downward Cabling



Vertical

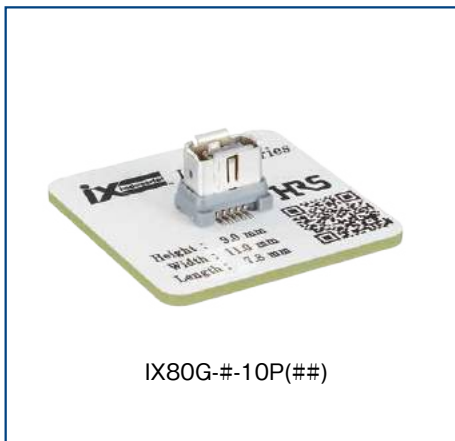

Right Angle, Upward Cabling



Note : Please use the same mating key (Type A, B) for both the plug and receptacle.

Receptacle

Upward Right Angle

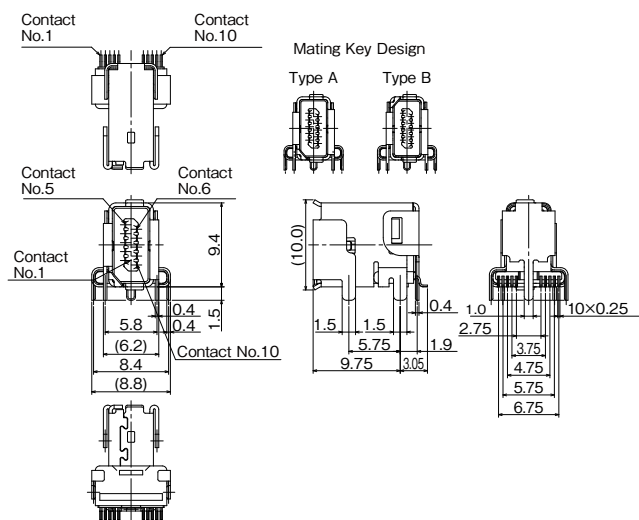

Part No.	HRS No.	Contact Area Plating	Purchase Unit
IX61G-A-10P	CL0251-0021-0-00	Gold Plated 0.2 μ m	400pcs per reel
IX61G-A-10P(01)	CL0251-0021-0-01	Palladium-Nickel Plated 0.75 μ m + Gold Plated 0.05 μ m	
IX61G-B-10P	CL0251-0026-0-00	Gold plated 0.2 μ m	
IX61G-B-10P(01)	CL0251-0026-0-01	Palladium-Nickel Plated 0.75 μ m + Gold Plated 0.05 μ m	

Right Angle

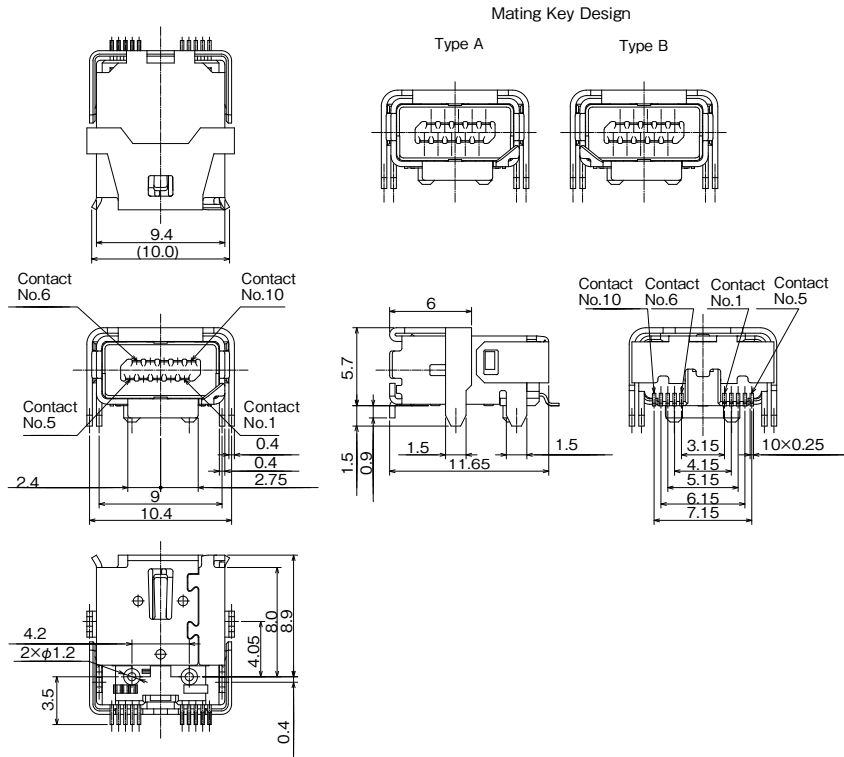

Part No.	HRS No.	Contact Area Plating	Purchase Unit
IX60G-A-10P	CL0251-0016-0-00	Gold Plated 0.2 μ m	550pcs per reel
IX60G-A-10P(01)	CL0251-0016-0-01	Palladium-Nickel Plated 0.75 μ m + Gold Plated 0.05 μ m	
IX60G-B-10P	CL0251-0017-0-00	Gold Plated 0.2 μ m	
IX60G-B-10P(01)	CL0251-0017-0-01	Palladium-Nickel Plated 0.75 μ m + Gold Plated 0.05 μ m	

Vertical

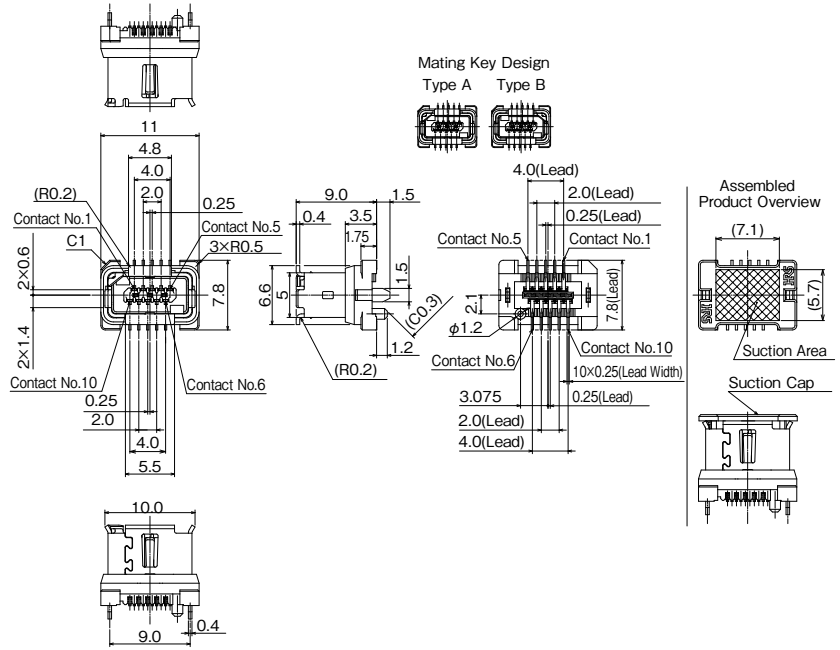

Part No.	HRS No.	Contact Area Plating	Purchase Unit
IX80G-A-10P	CL0251-0018-0-00	Gold Plated 0.2 μ m	450pcs per reel
IX80G-A-10P(01)	CL0251-0018-0-01	Palladium-Nickel Plated 0.75 μ m + Gold Plated 0.05 μ m	
IX80G-B-10P	CL0251-0019-0-00	Gold Plated 0.2 μ m	
IX80G-B-10P(01)	CL0251-0019-0-01	Palladium-Nickel Plated 0.75 μ m + Gold Plated 0.05 μ m	

Note : This product is delivered with a cap for Pick & Place mounting.
Please remove the cap before use.

Plug

Straight

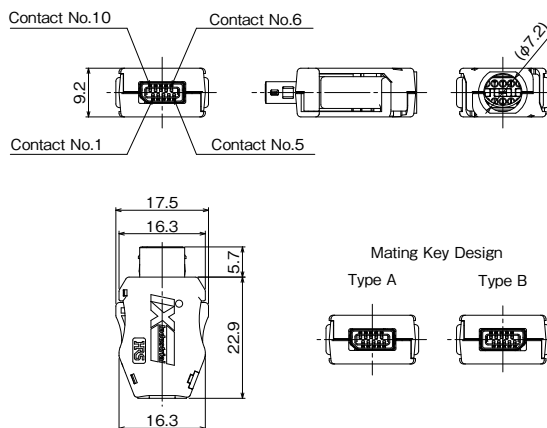

Part No.	HRS No.	Contact Area Plating	Purchase Unit
IX40G-A-10S-CV(7.0)	CL0251-0022-0-00	Gold Plated 0.2 μ m	100pcs per tray
IX40G-A-10S-CV(7.0)(01)	CL0251-0022-0-01	Palladium-Nickel Plated 0.75 μ m + Gold Plated 0.05 μ m	
IX40G-B-10S-CV(7.0)	CL0251-0032-0-00	Gold Plated 0.2 μ m	
IX40G-B-10S-CV(7.0)(01)	CL0251-0032-0-01	Palladium-Nickel Plated 0.75 μ m + Gold Plated 0.05 μ m	
IX30G-A-10S-CV(7.0)	CL0251-0020-0-00	Gold Plated 0.2 μ m	
IX30G-A-10S-CV(7.0)(01)	CL0251-0020-0-01	Palladium-Nickel Plated 0.75 μ m + Gold Plated 0.05 μ m	
IX30G-B-10S-CV(7.0)	CL0251-0025-0-00	Gold Plated 0.2 μ m	
IX30G-B-10S-CV(7.0)(01)	CL0251-0025-0-01	Palladium-Nickel Plated 0.75 μ m + Gold Plated 0.05 μ m	
IX31G-A-10S-CV(7.0)	CL0251-0023-0-00	Gold Plated 0.2 μ m	
IX31G-A-10S-CV(7.0)(01)	CL0251-0023-0-01	Palladium-Nickel Plated 0.75 μ m + Gold Plated 0.05 μ m	
IX31G-B-10S-CV(7.0)	CL0251-0024-0-00	Gold Plated 0.2 μ m	
IX31G-B-10S-CV(7.0)(01)	CL0251-0024-0-01	Palladium-Nickel Plated 0.75 μ m + Gold Plated 0.05 μ m	
IX32G-A-8S-CV(7.0) (Note)	CL0251-0042-0-00	Gold Plated 0.2 μ m	
IX32G-A-8S-CV(7.0)(01) (Note)	CL0251-0042-0-01	Palladium-Nickel Plated 0.75 μ m + Gold Plated 0.05 μ m	
IX32G-B-8S-CV(7.0) (Note)	CL0251-0043-0-00	Gold Plated 0.2 μ m	
IX32G-B-8S-CV(7.0)(01) (Note)	CL0251-0043-0-01	Palladium-Nickel Plated 0.75 μ m + Gold Plated 0.05 μ m	

Note : Cable assembly for IX32G is possible up to 8 positions.
 Contacts No. 3 and 8 do not have a hole to pass the wire through the IDC guide.

Right Angle, Downward Cabling

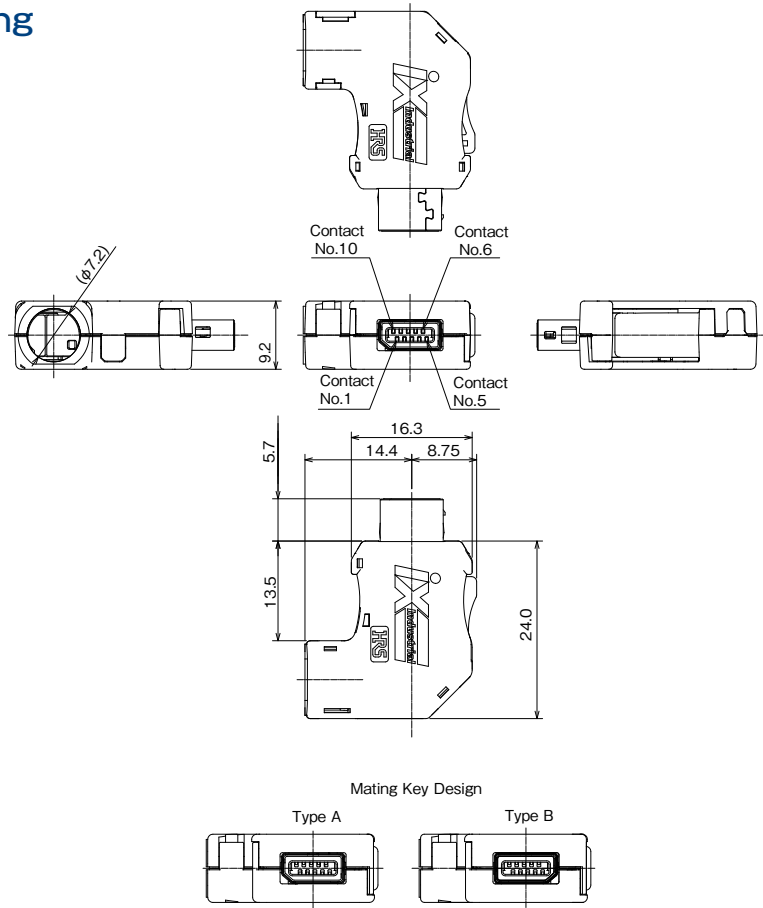

Part No.	HRS No.	Contact Area Plating	Purchase Unit
IX30G-A-10S-CVL1(7.0)	CL0251-0063-0-00	Gold Plated 0.2 μ m	100pcs per tray
IX30G-A-10S-CVL1(7.0)(01)	CL0251-0063-0-01	Palladium-Nickel Plated 0.75 μ m+ Gold Plated 0.05 μ m	
IX30G-B-10S-CVL1(7.0)	CL0251-0064-0-00	Gold Plated 0.2 μ m	
IX30G-B-10S-CVL1(7.0)(01)	CL0251-0064-0-01	Palladium-Nickel Plated 0.75 μ m+ Gold Plated 0.05 μ m	
IX31G-A-10S-CVL1(7.0)	CL0251-0067-0-00	Gold Plated 0.2 μ m	
IX31G-A-10S-CVL1(7.0)(01)	CL0251-0067-0-01	Palladium-Nickel Plated 0.75 μ m+ Gold Plated 0.05 μ m	
IX31G-B-10S-CVL1(7.0)	CL0251-0068-0-00	Gold Plated 0.2 μ m	
IX31G-B-10S-CVL1(7.0)(01)	CL0251-0068-0-01	Palladium-Nickel Plated 0.75 μ m+ Gold Plated 0.05 μ m	
IX32G-A-8S-CVL1(7.0)	CL0251-0071-0-00	Gold Plated 0.2 μ m	
IX32G-A-8S-CVL1(7.0)(01)	CL0251-0071-0-01	Palladium-Nickel Plated 0.75 μ m+ Gold Plated 0.05 μ m	
IX32G-B-8S-CVL1(7.0)	CL0251-0072-0-00	Gold Plated 0.2 μ m	
IX32G-B-8S-CVL1(7.0)(01)	CL0251-0072-0-01	Palladium-Nickel Plated 0.75 μ m+ Gold Plated 0.05 μ m	
IX40G-A-10S-CVL1(7.0)	CL0251-0075-0-00	Gold Plated 0.2 μ m	
IX40G-A-10S-CVL1(7.0)(01)	CL0251-0075-0-01	Palladium-Nickel Plated 0.75 μ m+ Gold Plated 0.05 μ m	
IX40G-B-10S-CVL1(7.0)	CL0251-0076-0-00	Gold Plated 0.2 μ m	
IX40G-B-10S-CVL1(7.0)(01)	CL0251-0076-0-01	Palladium-Nickel Plated 0.75 μ m+ Gold Plated 0.05 μ m	

Right Angle, Upward Cabling

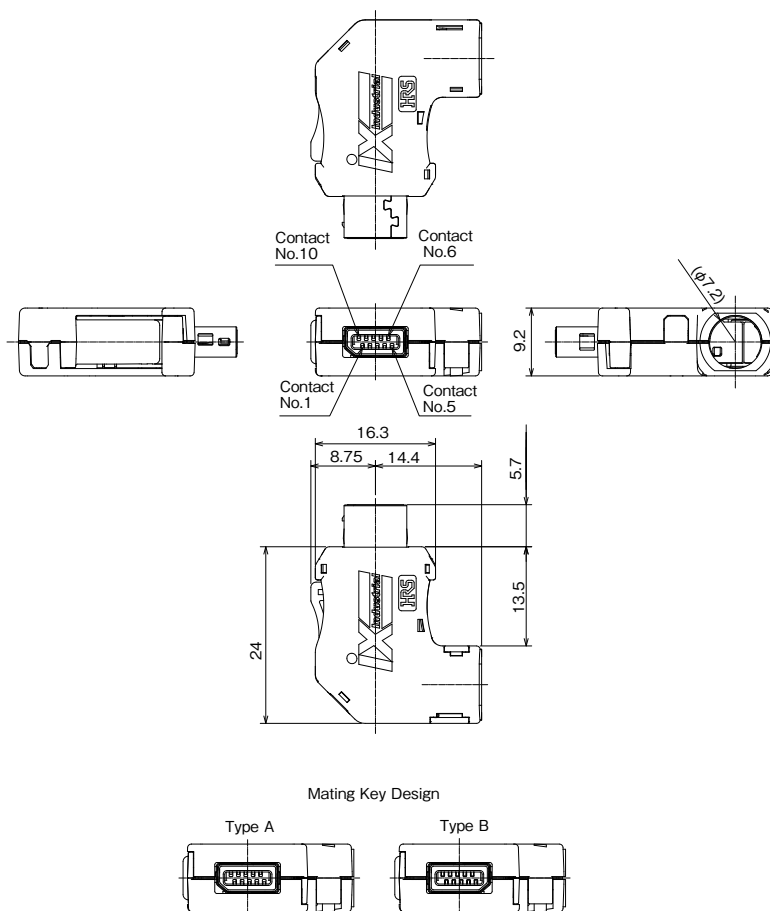

Part No.	HRS No.	Contact Area Plating	Purchase Unit
IX30G-A-10S-CVL2(7.0)	CL0251-0065-0-00	Gold Plated 0.2 μ m	100pcs per tray
IX30G-A-10S-CVL2(7.0)(01)	CL0251-0065-0-01	Palladium-Nickel Plated 0.75 μ m + Gold Plated 0.05 μ m	
IX30G-B-10S-CVL2(7.0)	CL0251-0066-0-00	Gold Plated 0.2 μ m	
IX30G-B-10S-CVL2(7.0)(01)	CL0251-0066-0-01	Palladium-Nickel Plated 0.75 μ m + Gold Plated 0.05 μ m	
IX31G-A-10S-CVL2(7.0)	CL0251-0069-0-00	Gold Plated 0.2 μ m	
IX31G-A-10S-CVL2(7.0)(01)	CL0251-0069-0-01	Palladium-Nickel Plated 0.75 μ m + Gold Plated 0.05 μ m	
IX31G-B-10S-CVL2(7.0)	CL0251-0070-0-00	Gold Plated 0.2 μ m	
IX31G-B-10S-CVL2(7.0)(01)	CL0251-0070-0-01	Palladium-Nickel Plated 0.75 μ m + Gold Plated 0.05 μ m	
IX32G-A-8S-CVL2(7.0)	CL0251-0073-0-00	Gold Plated 0.2 μ m	
IX32G-A-8S-CVL2(7.0)(01)	CL0251-0073-0-01	Palladium-Nickel Plated 0.75 μ m + Gold Plated 0.05 μ m	
IX32G-B-8S-CVL2(7.0)	CL0251-0074-0-00	Gold Plated 0.2 μ m	
IX32G-B-8S-CVL2(7.0)(01)	CL0251-0074-0-01	Palladium-Nickel Plated 0.75 μ m + Gold Plated 0.05 μ m	
IX40G-A-10S-CVL2(7.0)	CL0251-0077-0-00	Gold Plated 0.2 μ m	
IX40G-A-10S-CVL2(7.0)(01)	CL0251-0077-0-01	Palladium-Nickel Plated 0.75 μ m + Gold Plated 0.05 μ m	
IX40G-B-10S-CVL2(7.0)	CL0251-0078-0-00	Gold Plated 0.2 μ m	
IX40G-B-10S-CVL2(7.0)(01)	CL0251-0078-0-01	Palladium-Nickel Plated 0.75 μ m + Gold Plated 0.05 μ m	

● IX80G-#-10P

Reference Board Mounting Dimensions
(From Mounting Side) (t=1.6)

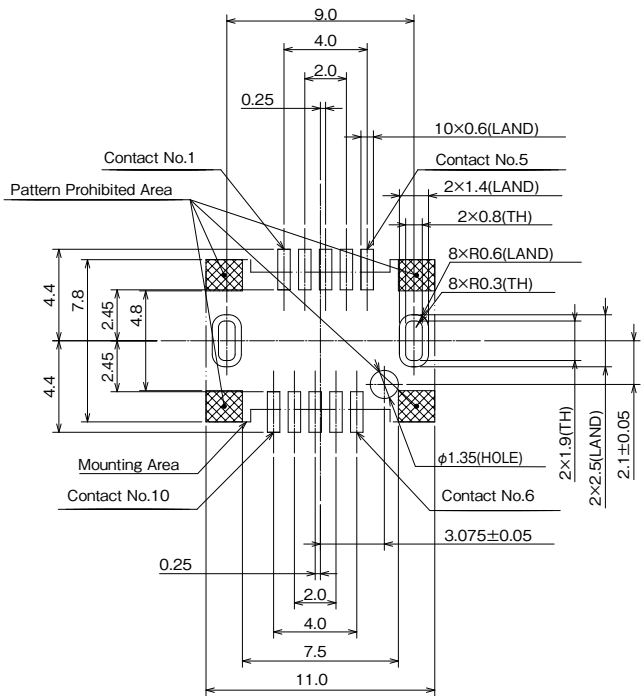

Note : Dimension tolerances not listed are ±0.05.

Recommended Metal Mask Pattern
(t=0.15)

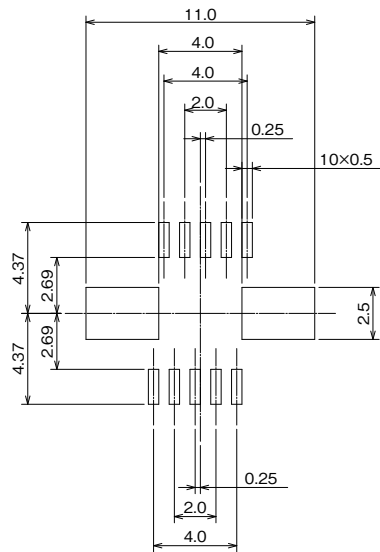

Note : Dimension tolerances not listed are ±0.02.

Panel Mounting Dimensions Diagram

IX61G-#-10P

Mated Condition

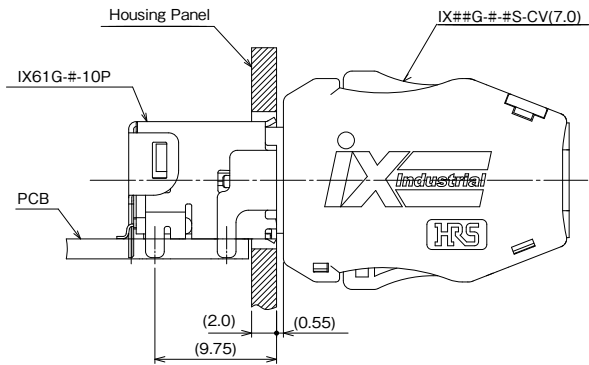

Reference Panel Cut-out Dimensions

Note : Dimensions are for reference.

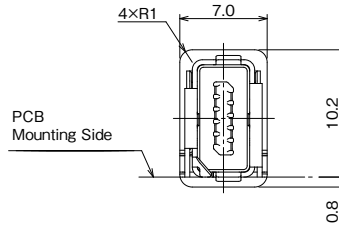

IX60G-#-10P

Mated Condition

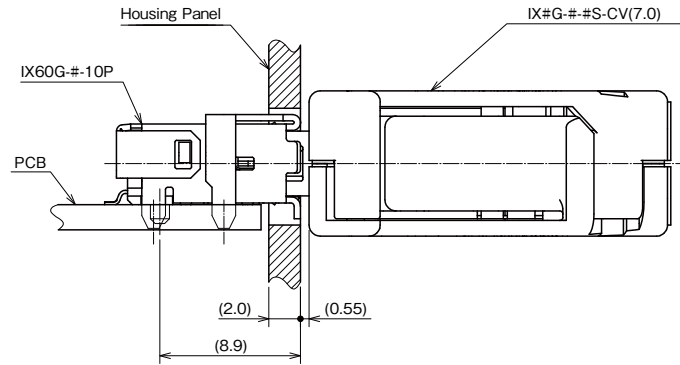

Reference Panel Cut-out Dimensions

Note : Dimensions are for reference.

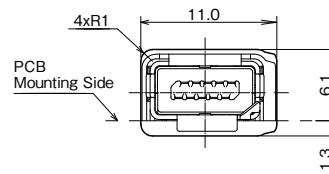

IX80G-#-10P

Mated Condition

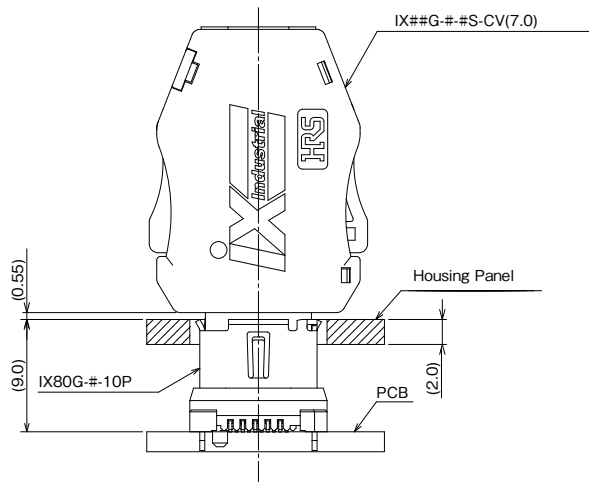

Reference Panel Cut-out Dimensions

Note : Dimensions are for reference.

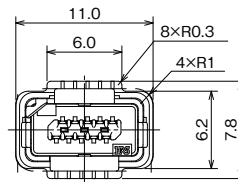

Cable Assembly Tools

Part No.	HRS No.	Applicable Connector
HT803/IXG-8/10S-63-72	CL0902-2218-0-00	IX##G-##-##S-CV(7.0)
HT803/IXG-10S-CVL-70	CL0902-2223-0-00	IX##G-##-##S-CVL1(7.0) IX##G-##-##S-CVL2(7.0)

Adapter for Cabling Certification Testing

This adapter requires the DSX CableAnalyzer™ from Fluke Networks for use.

Part No.	HRS No.
DSX-CHA-5-IX-S	CL0251-1001-0-00

(Note) DSX CableAnalyzer™ is a registered trademark of Fluke Networks.

Applicable Cables List

A list of applicable cables is available on the Hirose website.

(https://www.hirose.com/product/en/pr/ix_industrial/applicable_cable_list/)



While Taking into Consideration

Specifications mentioned in this catalog are reference values.

When considering to order or use this product, please confirm the Drawing and Product Specifications sheets.

Use an appropriate cable when using the connector in combination with cables.

If considering usage of a non-specified cable, please contact your sales representative.

If assembly process is done by jigs & tools which are not identified by Hirose, assurance will not be given.

If considering usage for below mentioned applications, please contact your sales representative.

In cases where the application will demand a high level of reliability, such as automotive, medical instruments, public infrastructure, aerospace/ defense etc. Hirose must review before assurance of reliability can be given.

X-ON Electronics

Largest Supplier of Electrical and Electronic Components

Click to view similar products for [Modular Connectors / Ethernet Connectors](#) category:

Click to view products by [Hirose](#) manufacturer:

Other Similar products are found below :

[8949-H88/06BLKA/SN](#) [74441-0010/BKN](#) [PHP-6P6C-5](#) [GAX-3-66](#) [GDCX-PN-66](#) [GLX-A-44](#) [GLX-N-1010M-BLK](#) [GLX-S-88M-BLK](#)
[GMX-SMT4-N-88](#) [GSGX-N-2-88](#) [GSGX-N-4-88](#) [GSX-NS2-88-3.05](#) [GSX-NS-88-3.68](#) [PT-108A-8C-UL](#) [PTS-J531-8CS-50UL](#) [A-2014-0-4](#)
[GWLX-S9-88-YG](#) [DC-1021-8-WH-6](#) [1300530003](#) [1324640-4](#) [132764-001](#) [1413235](#) [MPS88RX-5000](#) [E5288-S000K3-L](#) [155302-001](#)
[AX101050](#) [AX101063](#) [AX101065](#) [AX101072](#) [AX101307](#) [AX101315](#) [AX101318](#) [AX102271](#) [AX102651](#) [AX102660](#) [AX104024](#) [203475](#)
[J0026D01ENL](#) [PC4D0018P](#) [KIT38082NI](#) [8949-B88/6](#) [2-6609208-5](#) [30-8603](#) [30-8956](#) [30-8964-100](#) [SM85](#) [17-103540](#) [191587](#) [PDI-68-RV](#)
[PHP-8P8C-S-5](#)