

Sep.1.2021 Copyright 2021 HIROSE ELECTRIC CO., LTD. All Rights Reserved.
In case of consideration for using Automotive equipment / device which demand high reliability, kindly contact our sales window correspondents.

Fig. 2(1:1)

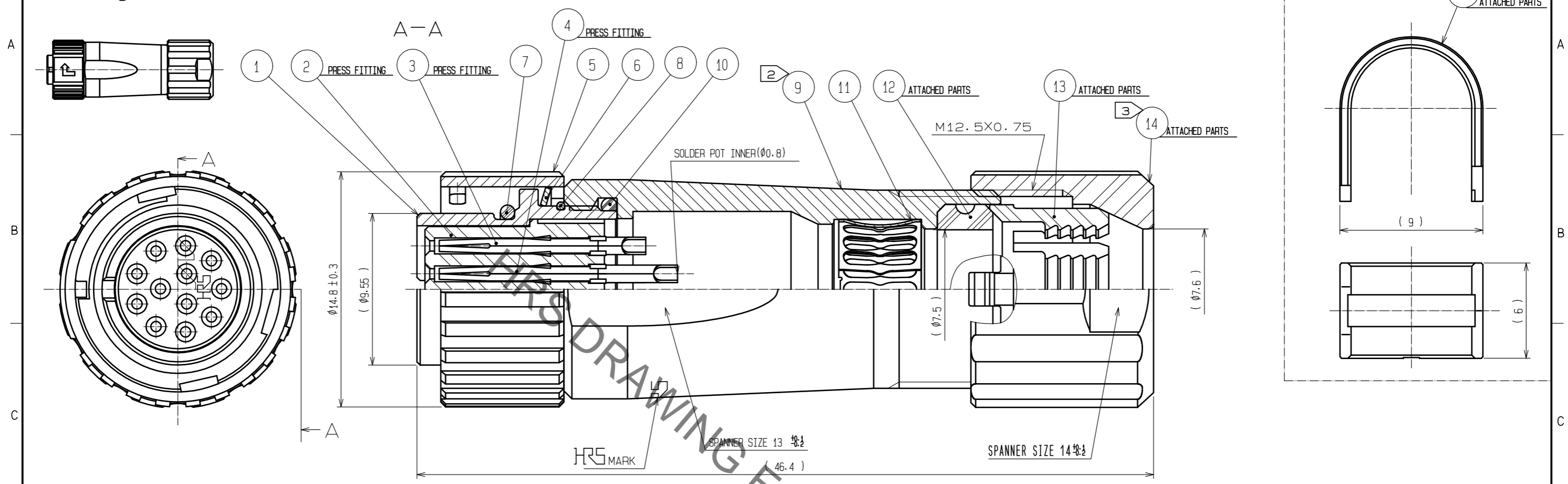
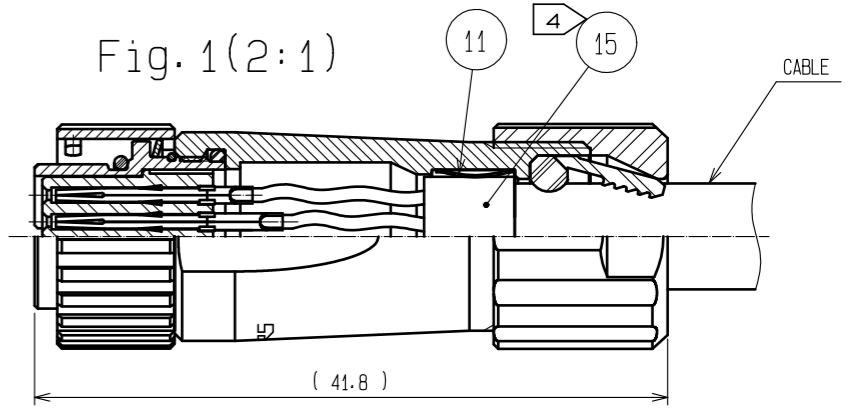

Fig. 1(2:1)



- NOTES
- 1 PLATING(REF.NO.③,④)
CONTACT AREA : GOLD 0.2μm min
OTHERS : GOLD AND NICKEL
UNDER PLATING : NICKEL 2μm min
 - 2 THE RECOMMENDED CLAMP TORQUE OF REF.NO.⑨ TO BE 1 TO 1.5N·m.
THREAD LOCKER TO THE THREADED PORTION OF REF.NO.① IS RECOMMENDED TO PREVENT REF.NO.⑨ FROM LOOSING.
RECOMMENDED THREAD LOCKER : LOCTITE 263, HENKEL JAPAN LTD.
 - 3 THE RECOMMENDED CLAMP TORQUE OF REF.NO.⑭ TO BE 0.8 TO 1N·m.
THREAD LOCKER AND LOCK PRIMER TO THE THREADED PORTION M12.5X0.75 OF REF.NO.⑨ IS RECOMMENDED TO PREVENT REF.NO.⑭ FROM LOOSING.
RECOMMENDED THREAD LOCKER AND LOCK PRIMER : LOCTITE 263, LOCK PRIMER 7649, HENKEL JAPAN LTD.
 - 4 FASTEN REF.NO.⑮ TO THE CABLE WITH THE CABLE CRIMPING TOOL.
AND MAKE REF.NO.⑮ CONTACT WITH REF.NO.⑪(REFER TO Fig.1).
REFER TO THE TECHNICAL SPECIFICATION ATAD-C0099 FOR DETAILS.
APPLICABLE CABLE CRIMPING TOOL : LF-TC-01 (CL150-0234-6)
 - 5 APPLICABLE CABLE ASSEMBLY FIXTURE : LF10BP-T01 (CL150-0235-9)
CABLE ASSEMBLY FIXTURE IS USED AS A RECEPTACLE STAND OF EXTRACT AND THE PART NUMBER ① OF AN ASSEMBLY.
 - 6 Fig.2 SHOWS THE APPEARANCE AFTER ASSEMBLY.
 - 7 ROTATION EXAMPLES OF REF. NOS.⑤,⑨ AND ⑭ TO ① ARE SHOWN.
 - 8 CABLE PULL FORCE, TWISTING STRENGTH, WATER TIGHTNESS AND OTHER CHARACTERISTICS MAY DIFFER DEPENDING ON CABLE SPECIFICATIONS AND STRUCTURE.
PLEASE EVALUATE UNDER THE ACTUAL CONDITIONS PRIOR TO USE.

NO.	MATERIAL	FINISH .	REMARKS	NO.	MATERIAL	FINISH .	REMARKS
8	STAINLESS STEEL			15	BRASS	NICKEL PLATING	
7	CHLOROPRENE RUBBER	(BLACK)		14	PPS	(NATURAL·BROWN)	UL94V-0
6	STAINLESS STEEL			13	POLYAMIDE	(NATURAL·MILKY WHITE)	UL94V-0
5	ZINC ALLOY	NICKEL PLATING		12	CHLOROPRENE RUBBER	(BLACK)	
4	PHOSPHOR BRONZE	①		11	PHOSPHOR BRONZE	NICKEL PLATING	
3	PHOSPHOR BRONZE	①		10	CHLOROPRENE RUBBER	(BLACK)	
2	PPS	(BLACK)	UL94V-0	9	ZINC ALLOY	NICKEL PLATING	
1	ZINC ALLOY	NICKEL PLATING					

UNITS	SCALE	COUNT	DESCRIPTION OF REVISIONS	DESIGNED	CHECKED	DATE
mm	4 : 1	△				
APPROVED : HY. KOBAYASHI			18.02.21	DRAWING NO. EDC-114242-31-00		
CHECKED : HY. KOBAYASHI			18.02.21	PART NO. LF10WBP-12S(31)		
DESIGNED : TY. SUZUKI			18.02.21	CODE NO. CL136-0007-8-31		
DRAWN : HM. SAITO			18.02.21			

X-ON Electronics

Largest Supplier of Electrical and Electronic Components

Click to view similar products for [Standard Circular Connector](#) category:

Click to view products by [Hirose](#) manufacturer:

Other Similar products are found below :

[5M2530B10P](#) [600259N006](#) [600273N007](#) [6134-336-13149](#) [6134-337-11149](#) [6134-337-2390](#) [6134-341-17149](#) [6280-4SG-516](#) [6280-7SG-3DC](#)
[6290](#) [6291A](#) [66200A-10](#) [680-SMG](#) [681-PMG](#) [CXS3102A14S2P](#) [CXS3102A181S](#) [7251-6SG-300](#) [7271-6SG-300](#) [7282-3PG-300-CH3](#) [75-](#)
[474014-05S](#) [75-474618-01S](#) [75-474618-04S](#) [799539-000](#) [MI8-SE](#) [805-005-07NF11-19PC](#) [805-005-07NF15-7PA](#) [8280-4PG-516](#) [8280-7PG-](#)
[519](#) [8282-5PG-519](#) [836783-1](#) [MP-4102-25P-C](#) [862256-1](#) [864019-2](#) [866857-1](#) [867865-1](#) [PT01SP-14-18P](#) [PT08P-14-5S](#) [PTSF06SE-14-12S](#)
[120-1833-000](#) [QCM019PC2DC012B](#) [1-2069279-1](#) [121583-0217](#) [121667-0020](#) [129591AU](#) [1000B BULK](#) [RD10A16-19-P6CS051/1](#)
[RD10A20-31-P8CS051/1](#) [RD16A14-12-S6CS051/2](#) [1301240290](#) [1301240347](#) [1301860202](#)