

Sep.1.2021 Copyright 2021 HIROSE ELECTRIC CO., LTD. All Rights Reserved.
In case of consideration for using Automotive equipment / device which demand high reliability, kindly contact our sales window correspondents.

Fig. 2 (1:1)

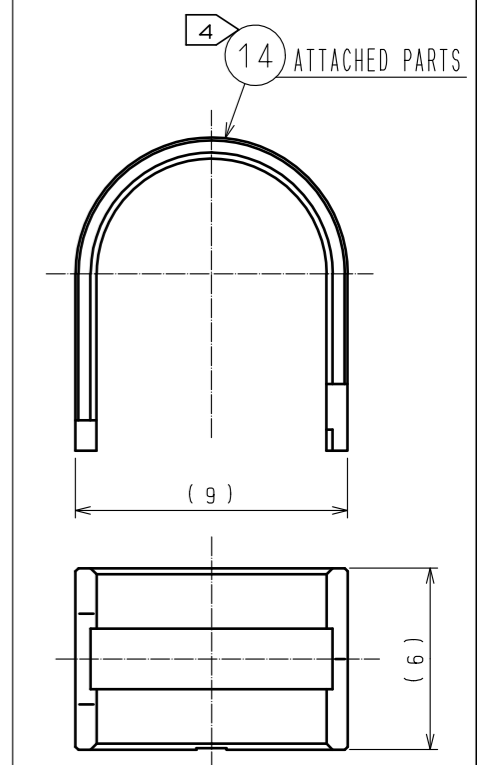
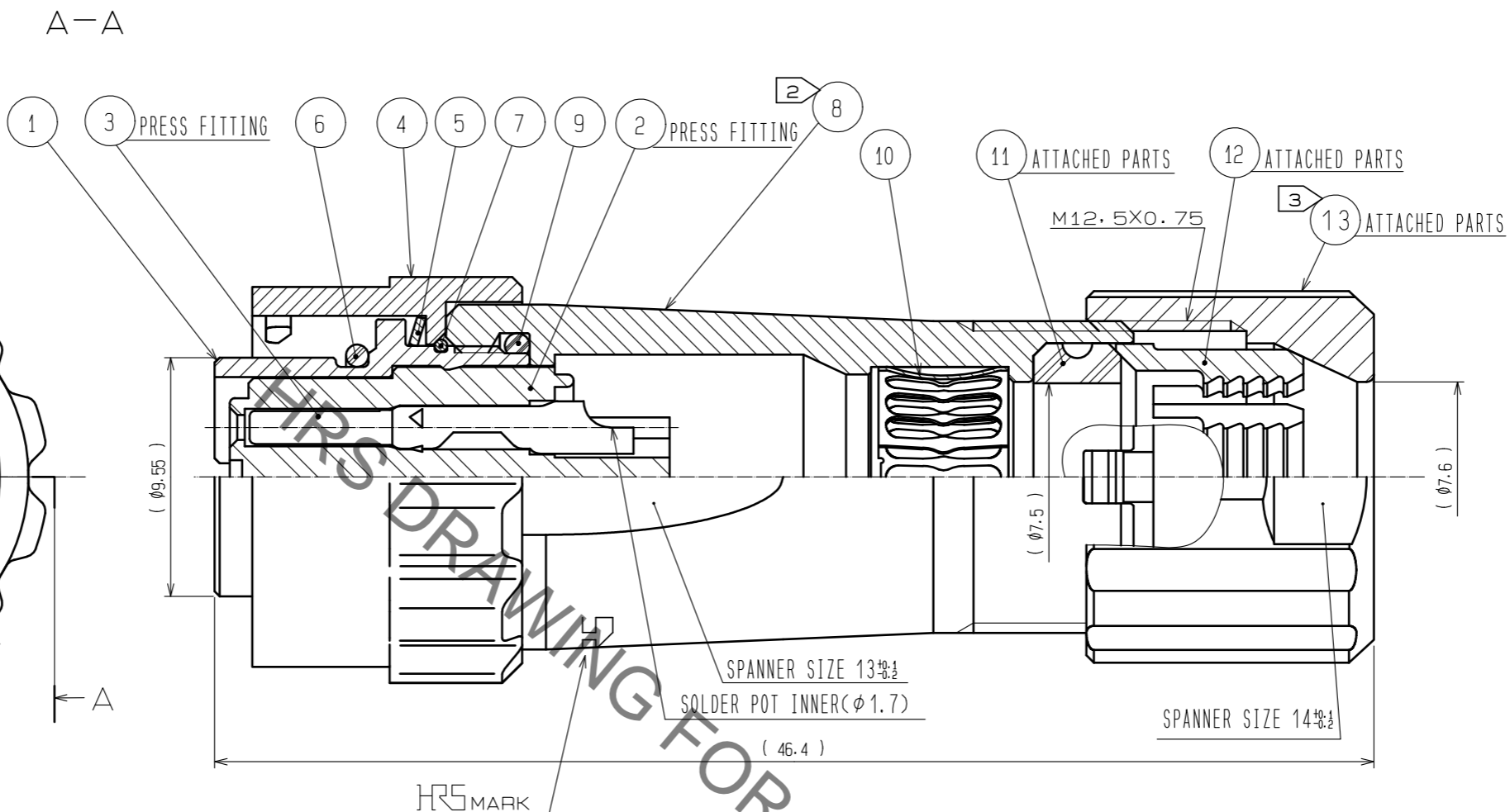
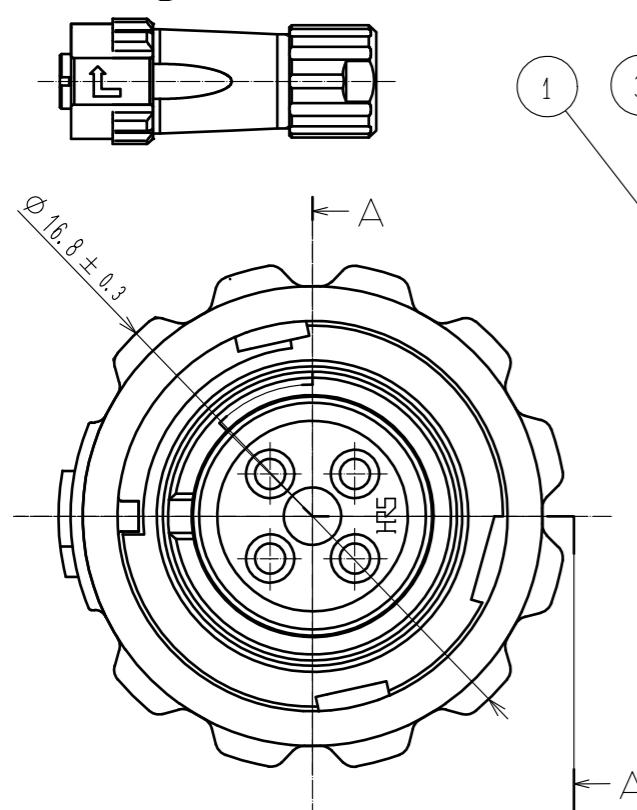
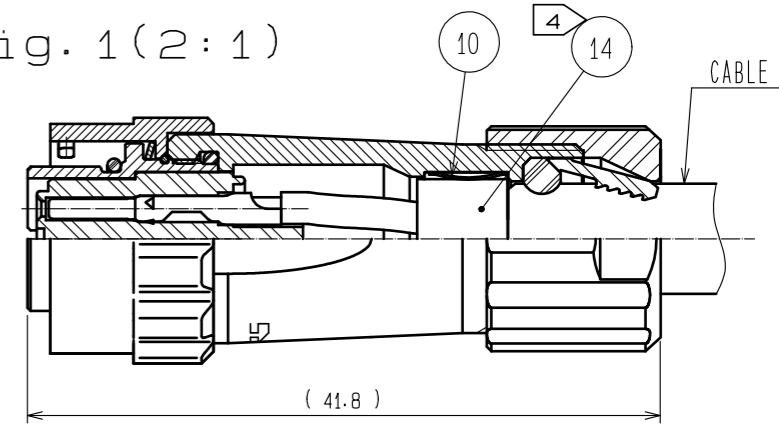

Fig. 1 (2:1)



- NOTES
- 1 PLATING (REF. NO. 3)
CONTACT AREA : GOLD 0.2μm min.
OTHERS : GOLD OR NICKEL
UNDER PLATING : NICKEL 2μm min.
 - 2 THE RECOMMENDED CLAMP TORQUE OF REF. NO. 8 TO BE 1 TO 1.5N·m.
THREAD LOCKER TO THE THREADED PORTION OF REF. NO. 1 IS RECOMMENDED TO PREVENT REF. NO. 8 FROM LOOSING.
RECOMMENDED THREAD LOCKER: LOCTITE 263, HENKEL JAPAN LTD.
 - 3 THE RECOMMENDED CLAMP TORQUE OF REF. NO. 13 TO BE 0.8 TO 1N·m.
THREAD LOCKER AND LOCK PRIMER TO THE THREADED PORTION M12.5X0.75 OF REF. NO. 8 IS RECOMMENDED TO PREVENT REF. NO. 13 FROM LOOSING.
RECOMMENDED THREAD LOCKER AND LOCK PRIMER : LOCTITE 263, LOCK PRIMER 7649, HENKEL JAPAN LTD.
 - 4 FASTEN REF. NO. 14 TO THE CABLE WITH THE CABLE CRIMPING TOOL.
AND MAKE REF. NO. 14 CONTACT WITH REF. NO. 10 (REFER TO Fig. 1).
REFER TO THE TECHNICAL SPECIFICATION ETAD-C0099 FOR DETAILS.
APPLICABLE CABLE CRIMPING TOOL : LF-TC-01 (CL150-0234-6)
 - 5 Fig. 2 SHOWS THE APPEARANCE AFTER ASSEMBLY.
 - 6 APPLICABLE CABLE ASSEMBLY FIXTURE : LF10BP-T01 (CL150-0235-9)
CABLE ASSEMBLY FIXTURE IS USED AS A RECEPTACLE STAND OF EXTRACT AND THE PART NUMBER 1 OF AN ASSEMBLY.
 - 7 ROTATION EXAMPLES OF REF. 4, 8 AND 13 TO 1 ARE SHOWN.
 - 8 THE CABLE PULL, TWISTING STRENGTH, WATERPROOF ABILITY AND OTHER CHARACTERISTICS MAY DIFFER, DEPENDING ON THE CABLE STRUCTURE, PLEASE CONFIRM BEFORE THE USE.

7	STAINLESS STEEL		14	BRASS	NICKEL PLATING
6	CHLOROPRENE RUBBER	(BLACK)	13	PPS	(NATURAL·BROWN) UL94V-0
5	STAINLESS STEEL		12	POLYAMIDE	(NATURAL·MILKY WHITE) UL94V-0
4	ZINC ALLOY	NICKEL PLATING	11	CHLOROPRENE RUBBER	(BLACK)
3	COPPER ALLOY	1	10	PHOSPHOR BRONZE	NICKEL PLATING
2	PPS	(BLACK) UL94V-0	9	CHLOROPRENE RUBBER	(BLACK)
1	ZINC ALLOY	NICKEL PLATING	8	ZINC ALLOY	NICKEL PLATING
NO.	MATERIAL	FINISH, REMARKS	NO.	MATERIAL	FINISH, REMARKS
UNITS mm		SCALE 4:1	COUNT	DESCRIPTION OF REVISIONS	
DESIGNED		CHECKED		DATE	
APPROVED : HY. KOBAYASHI 18.02.21			DRAWING NO. EDC-116728-31-00		
CHECKED : HY. KOBAYASHI 18.02.21			PART NO. LF10WBPD-4S(31)		
DESIGNED : TY. SUZUKI 18.02.21			CODE NO. CL136-0014-3-31		
DRAWN : HM. SAITO 18.02.16			1/1		

X-ON Electronics

Largest Supplier of Electrical and Electronic Components

Click to view similar products for [Standard Circular Connector](#) category:

Click to view products by [Hirose](#) manufacturer:

Other Similar products are found below :

[5M2530B10P](#) [600259N006](#) [600273N007](#) [6134-336-13149](#) [6134-337-11149](#) [6134-337-2390](#) [6134-341-17149](#) [6280-4SG-516](#) [6280-7SG-3DC6290](#) [6291A](#) [66200A-10](#) [680-SMG](#) [681-PMG](#) [CXS3102A14S2P](#) [CXS3102A181S](#) [7251-6SG-300](#) [7271-6SG-300](#) [7282-3PG-300-CH3](#) [75-474014-05S](#) [75-474618-01S](#) [75-474618-04S](#) [799539-000](#) [MI8-SE](#) [805-005-07NF11-19PC](#) [805-005-07NF15-7PA](#) [8280-4PG-516](#) [8280-7PG-519](#) [8282-5PG-519](#) [836783-1](#) [MP-4102-25P-C](#) [862256-1](#) [864019-2](#) [866857-1](#) [867865-1](#) [PT01SP-14-18P](#) [PT08P-14-5S](#) [PTSF06SE-14-12S](#) [120-1833-000](#) [QCM019PC2DC012B](#) [1-2069279-1](#) [121583-0217](#) [121667-0020](#) [129591AU](#) [1000B BULK](#) [RD10A16-19-P6CS051/1](#) [RD10A20-31-P8CS051/1](#) [RD16A14-12-S6CS051/2](#) [1301240290](#) [1301240347](#) [1301860202](#)