

Jan.1.2022 Copyright 2022 HIROSE ELECTRIC CO., LTD. All Rights Reserved.
 In case of consideration for using AutoRevise, please refer to the following URL: <http://www.hirose.com/revise>

△數 COUNT	訂正事項 DISCUSSION OF REVISIONS	擔當 B Y	檢圖 CHKD	年月日 DATE	△數 COUNT	訂正事項 DISCUSSION OF REVISIONS	擔當 B Y	檢圖 CHKD	年月日 DATE
△	2	RE-5-1422	K.M.G	C.D.H	16.05.20	△			
△					△				
△					△				

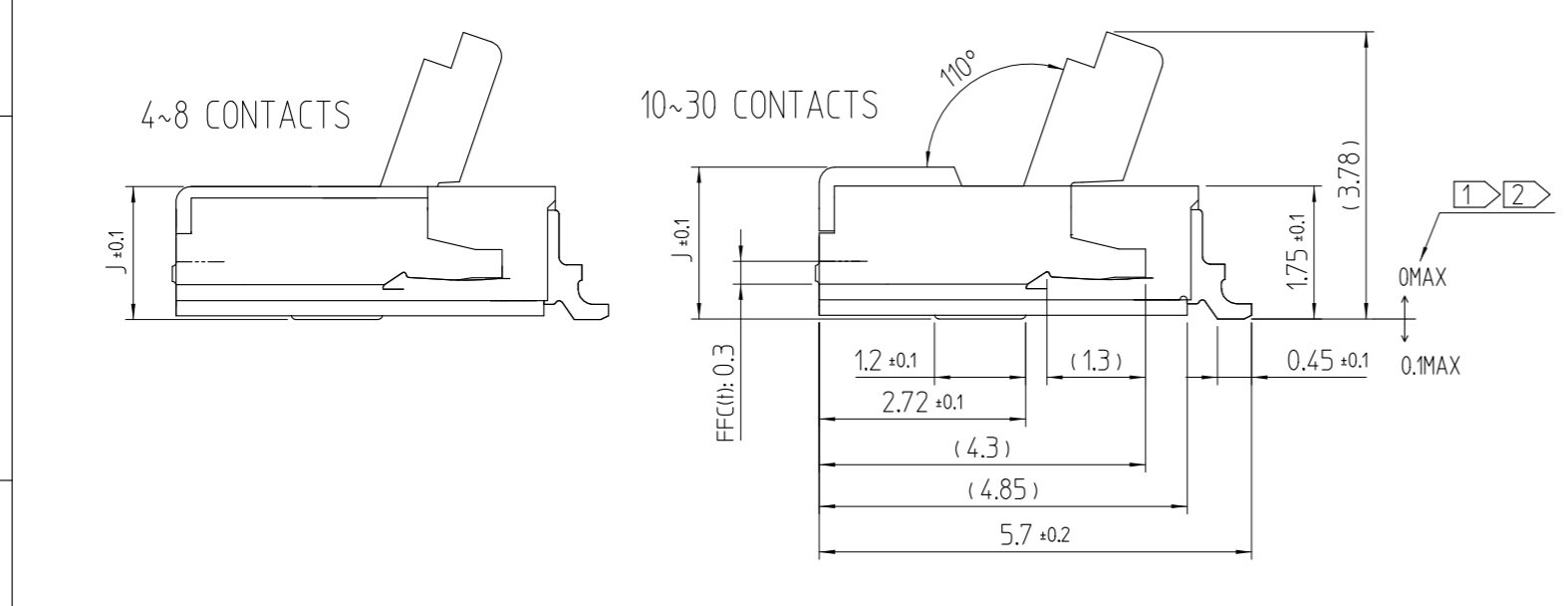

NOTE 1 : REFERENCE IS A.
 2 : LEAD CO-PLANARITY SHALL BE 0.1mm MAX

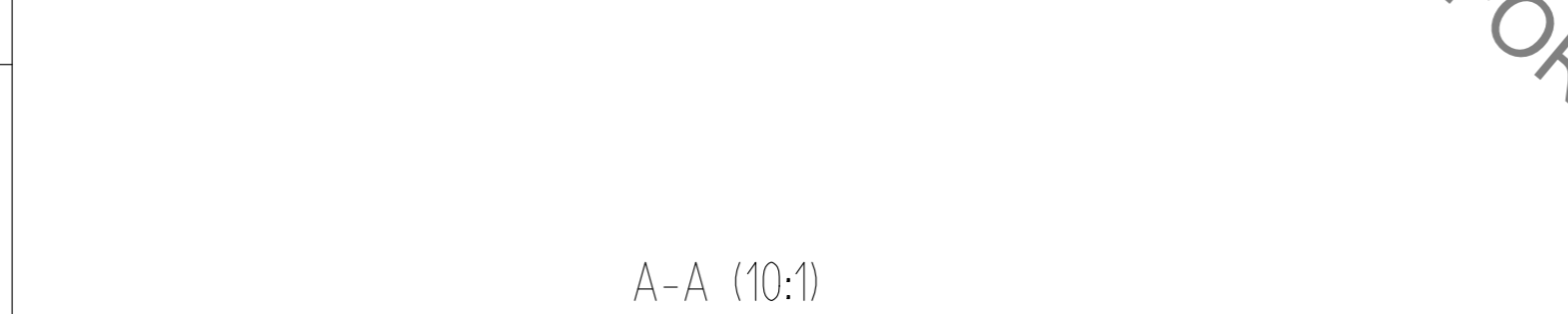
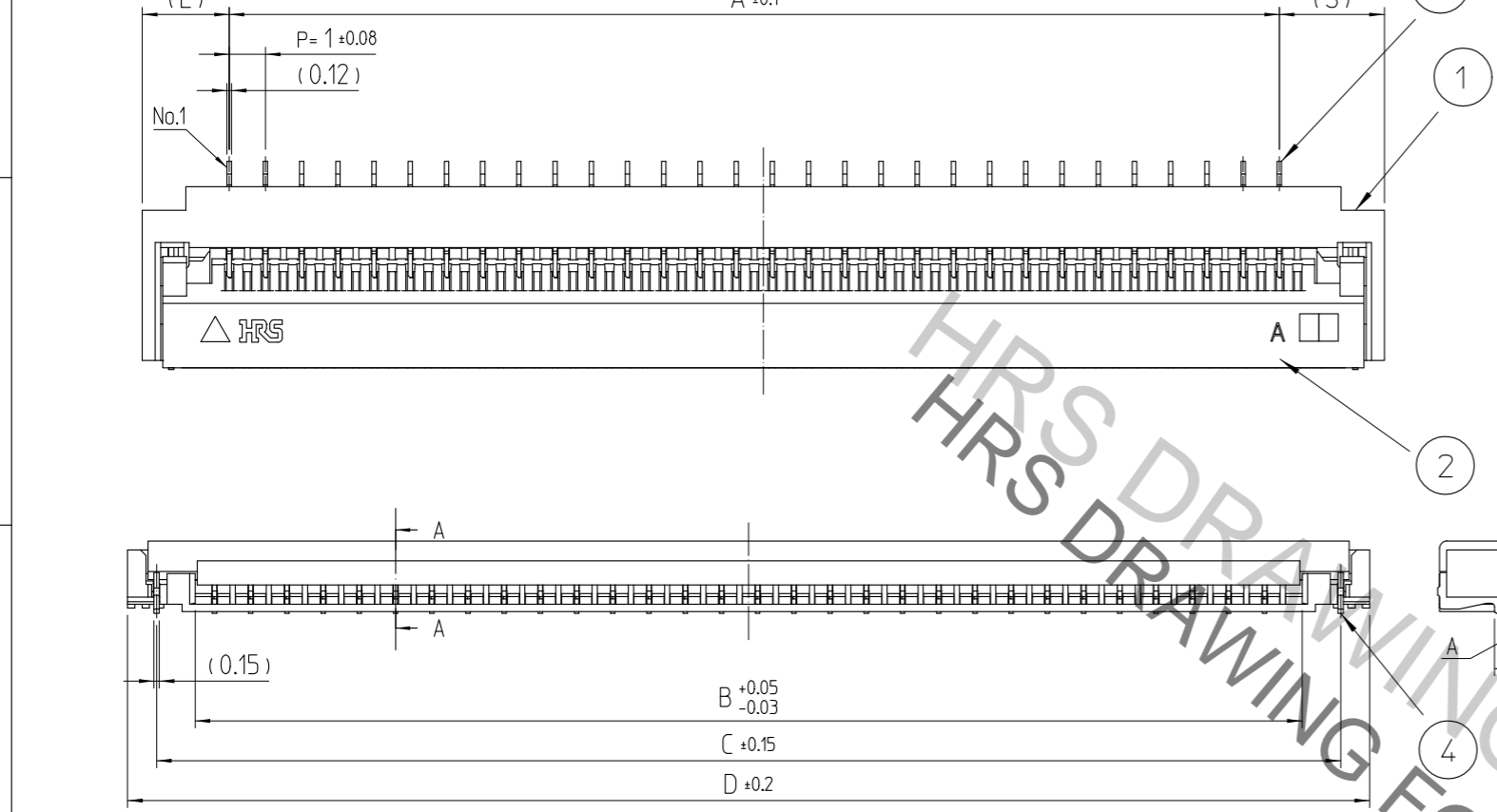
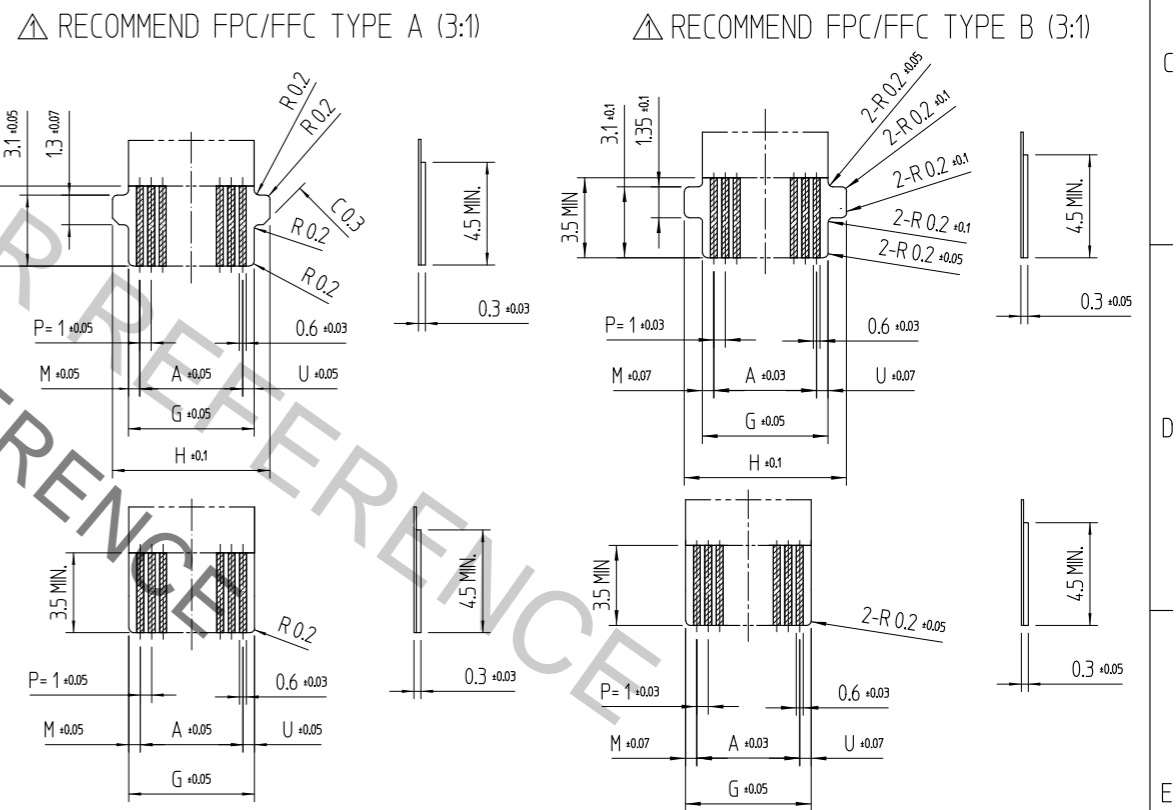
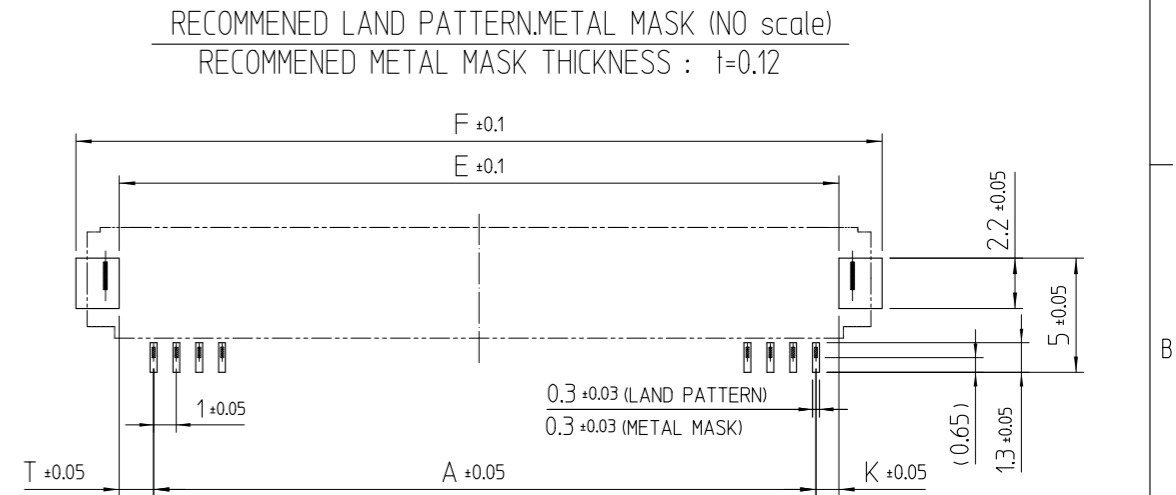

2	LCP	UL94V-0, BLACK	4	BRASS	TIN PLATING 1um MIN. OVER COPPER 0.3um MIN
1	LCP	UL94V-0, BEIGE	3	PHOSPHOR BRONZE	GOLD PLATING 0.03um MIN. OVER NICKEL 1um MIN
NO.	MATERIAL	FINISH,REMARKS	NO.	MATERIAL	FINISH,REMARKS
CODE NO. (OLD)			DRAWN	DESIGNED	CHECKED
DRAWING NO.			PART NO. TF31-* *S-1SH (800)		
SCALE 5:1			CODE NO.		
UNITS mm			HRS HIROSE KOREA CO.,LTD.		

Jan. 1. 2022 Copyright 2022 HIROSE ELECTRIC CO., LTD. All Rights Reserved.
 use of consideration for using Autorip v.2019 for device with copyright reserved window correspondi

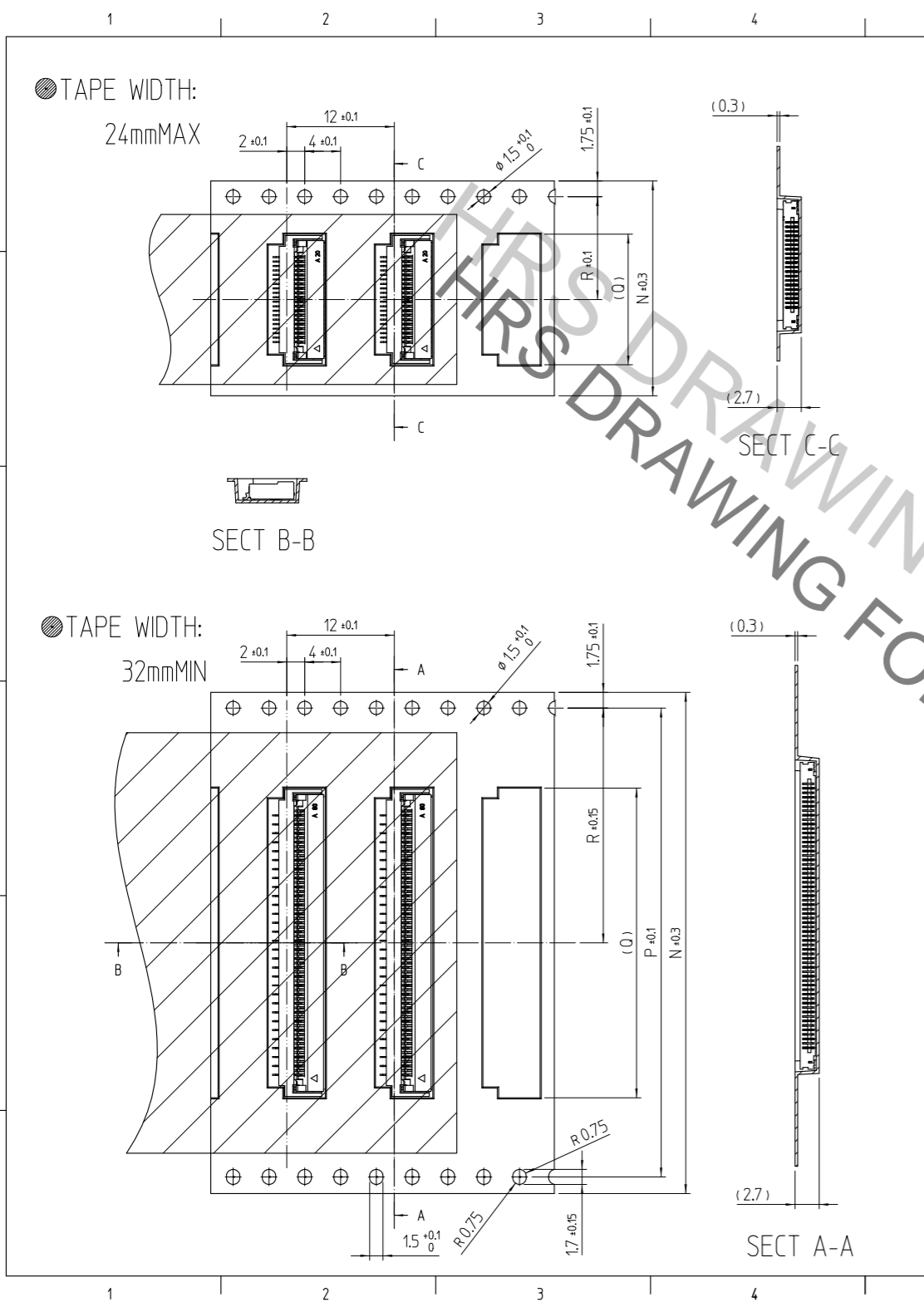

△數 COUNT	訂正事項 DISCRIPTION OF REVISIONS	擔當 B Y	檢圖 CHKD	年月日 DATE	△數 COUNT	訂正事項 DISCRIPTION OF REVISIONS	擔當 B Y	檢圖 CHKD	年月日 DATE
△					△				
△					△				
△					△				

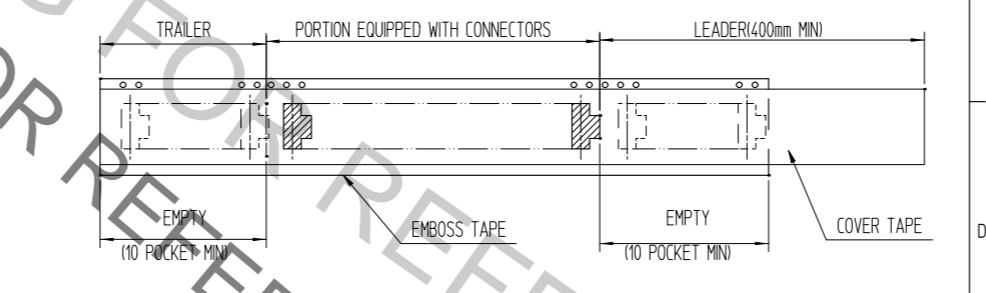
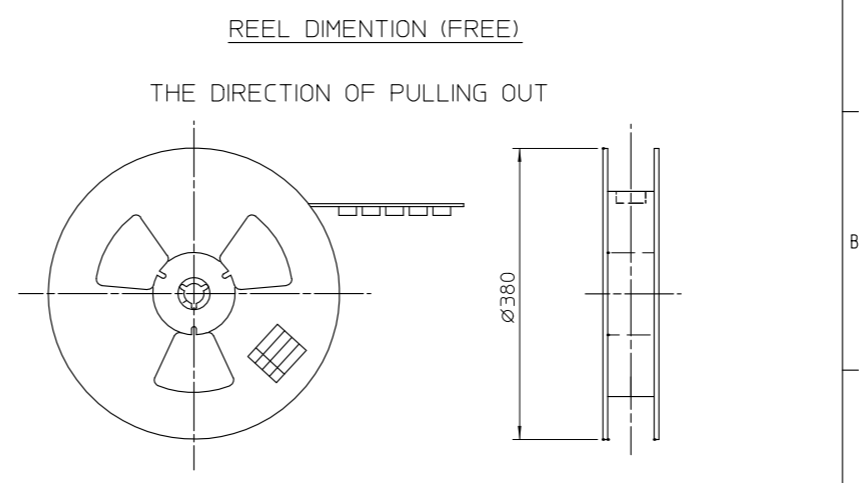

NOTE 1. 1REEL CONTAINS 3,000PCS.

NO.	MATERIAL	FINISH,REMARKS	NO.	MATERIAL	FINISH,REMARKS
CODE NO. (OLD)			DRAWN	DESIGNED	CHECKED
			SEO 15.06.01 S.H	SEO 15.06.01 S.H	CHO 15.06.01 D.H
					APPROVED
					SONG 15.06.01 H.C
					RELEASED
					ENG 15.06.01 DEPT

DRAWING NO. _____ PART NO. TF31-xxS-1SH (800)
 SCALE 2:1 UNITS mm CODE NO. 3

Jan. 1.2022 Copyright 2022 HIROSE ELECTRIC CO., LTD. All Rights Reserved.
 use of consideration for using Autorip...
 HRS DRAWING FOR REFERENCE

△數 COUNT	訂正事項 DISCRPTION OF REVISIONS	擔當 B Y	檢圖 CHKD	年月日 DATE	△數 COUNT	訂正事項 DISCRPTION OF REVISIONS	擔當 B Y	檢圖 CHKD	年月日 DATE
△					△				
△					△				
△					△				

●Standard Type 1mm PITCH

PART NUMBER	CODE NUMBER	NUMBER OF CONTACTS	DIMENSION OF CONNECTOR/ FPC, PCB MOUNTING PATTERN															DIMENSION OF PACKING			
			A	B	C	D	E	F	G	H	J	K	L	M	S	T	U	N	P	Q	R
TF31-6S-1SH(800)	CL 6535-0027-1-800	6S	5	7.07	9.2	10.8	8	11.8	7	8.4	1.75	1.5	2.9	1	2.9	1.5	1	24	-	11.1	11.5
TF31-8S-1SH(800)	CL6535-0040-0-800	8S	7	9.07	11.2	12.8	10	13.8	9	10.4	1.75	1.5	2.9	1	2.9	1.5	1	24	-	13.1	11.5
TF31-10S-1SH(800)	CL 6535-0041-2-800	10S	9	11.07	13.2	14.8	12	15.8	11	12.4	2	1.5	2.9	1	2.9	1.5	1	32	28.4	15.1	14.2
TF31-26S-1SH(800)	CL 6535-0051-6-800	26S	25	27.07	29.2	30.8	28	31.8	27	28.4	2	1.5	2.9	1	2.9	1.5	1	44	40.4	31.1	20.2

●Eccentric Type 1mm PITCH

PART NUMBER	CODE NUMBER	NUMBER OF CONTACTS	DIMENSION OF CONNECTOR/ FPC, PCB MOUNTING PATTERN															DIMENSION OF PACKING			
			A	B	C	D	E	F	G	H	J	K	L	M	S			N	P	Q	R
TF31-10(4)SA-1SH(800)	CL 6535-0043-8-800	4S	3	5.57	7.7	9.3	6.5	10.3	5.5	6.9	1.75	1.5	2.9	1	3.4			16	-	9.6	7.5
TF31-40(20)SB-1SH(800)	CL 6535-0042-5-800	20S	19	20.57	22.7	24.3	21.5	25.3	20.5	21.9	2	1	2.4	0.5	2.9			44	40.4	24.6	20.2
TF31-60(30)SB-1SH(800)	CL 6535-0012-4-800	30S	29	30.57	32.7	34.3	31.5	35.3	30.5	31.9	2	1	2.4	0.5	2.9			56	52.4	34.6	26.2

*Contact positions without code numbers are currently under planning.
 Contact HIROSE for detailed information about product variation

DETAIL OF PART NO. LABEL

현 품 표	
MODEL NAME	MODEL 명 TF31-**-1SH(800)
LOT NO.	LOT 번호
QUANTITY	수 량 3,000 PCS
INSPECTOR	검 사 자
SUPPLIER	HRS 히로세 코리아 주식회사 <small>이 문서는 발품 및 로트 추적 관련 사항에 한합니다.</small>

NO.	MATERIAL	FINISH.REMARKS	NO.	MATERIAL	FINISH.REMARKS		
CODE NO. (OLD)			DRAWN	DESIGNED	CHECKED	APPROVED	RELEASED
			SEO 15.06.01 S.H	SEO 15.06.01 S.H	CHO 15.06.01 D.H	SONG 15.06.01 H.C	ENG 15.06.01 DEPT.
DRAWING NO.			PART NO. TF31-**-1SH (800)				
SCALE 1:1 UNITS mm			HRS HIROSE KOREA CO.,LTD.			CODE NO	3/5

This connector requires delicate and careful handling.
 Read through the instructions shown below and the connector properly.
 Each values indicating here are for reference and may differ from standard value.

[INSTRUCTIONS FOR MOUNTING ON THE BOARD]

- ◆ **Warp of Board**
 Minimize warp of the board as possible
 Lead co-planarity including reinforced metal fitting is 0.1mm or less
 Too much warp of the board may result in a soldering.
- ◆ **Load to Connector**
 Do not apply a force of 0.5N or more to the connector before mounting it on the board.
 Otherwise, the connector may be broken.
 Do not warp the FPC or operate the connector before mounting it.
- ◆ **Load to board**
 *Splitting a large board into several pieces
 *Screwing the board
 Avoid the handling described above so that no force is exerted on the board during the assembly process.
 Otherwise, the connector may become defective.
- ◆ **Amount of Warp**
 The warp of a 100-mmwide board should be 0.5mm or less.
 The warp of board suffers stress on connector and connector may become defective.

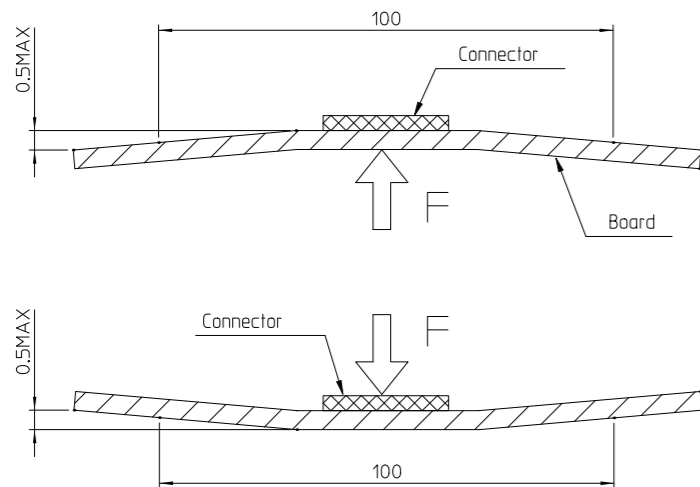

[INSTRUCTIONS ON INSERTING FFC/FPC AND CONNECTOR]

- ◆ **Use of the Actuator**
 1. Be very careful not to apply excessive force when releasing the Actuator.
 in the initial position
 if you use your nail or finger as shown, the terminals may be deformed.

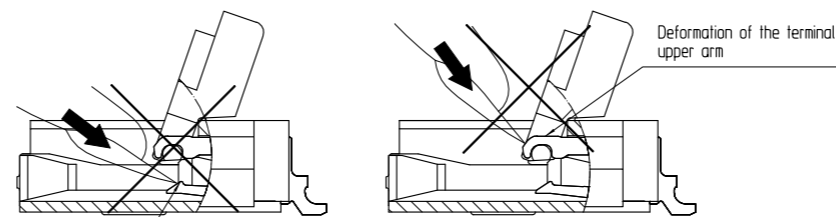

- 2. The actuator rotates around the rotational axis as shown below.
 Rotate the actuator.
- 3. The actuator will not open more than 110°.
 Do not apply any force backward beyond this point.
 Otherwise the actuator may come off or break.

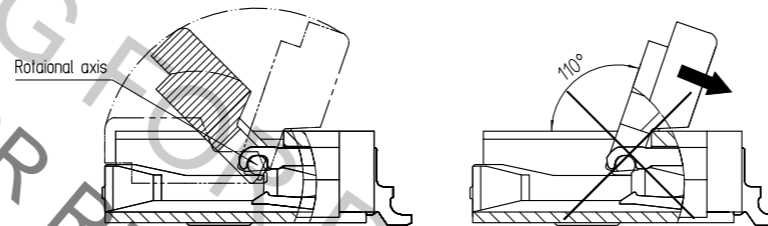

- 4. Move the actuator at approximately the center.
- 5. Do not pinch or pick the actuator to lift it as shown below. Otherwise it may break.
 (Do not carry out any operation other than rotating the actuator as shown in 2 above.)

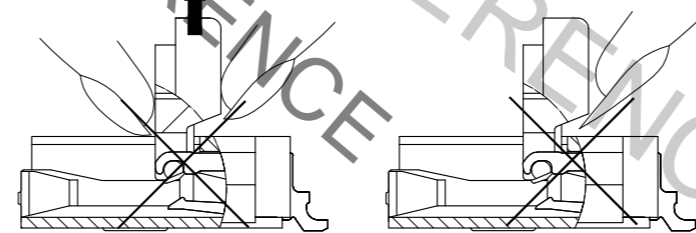

<INSTRUCTION MANUAL(1)>

DRAWING NO.	PART NO.	TF31-**S-1SH(800)
HRS HIROSE KOREA CO.,LTD.	CODE NO.	3
		4/5

- ◆ Direction of Contacts
This connector has contacts on the bottom. Thus, insert FFC/FPC with the exposed conductors face down.
- ◆ Inserting the FFC/FPC
1. Insert the FFC/FPC by about 10 degrees along the surface and at a right angle to the connector.
Insert it properly to the very end.

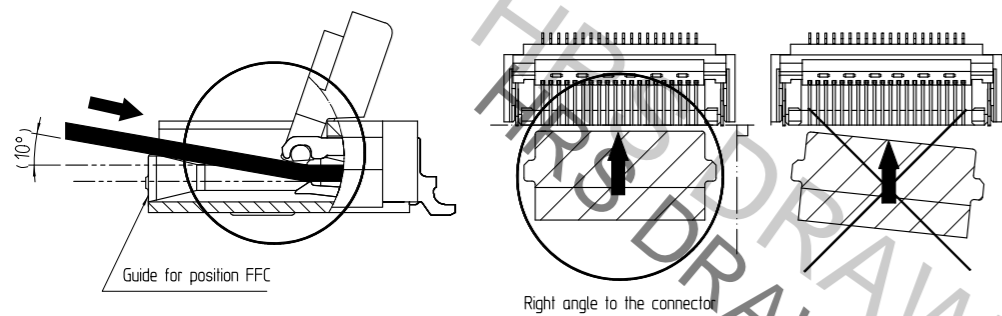

- 2. Do not insert the FFC/FPC diagonally from above.
If the FFC/FPC is inserted at a slant (incorrectly) as shown below in the FFC/FPC insertion process, the edge of the FFC/FPC may catch in the terminals resulting in deformation of the terminals. the FFC/FPC may bend and patterns may break or the FFC may not insert completely, resulting in improper conduction.
- ※ Keep a sufficient FFC/FPC insertion space in the stage of the layout in order to avoid incorrect FFC/FPC insertion. Besides, it is not difficult to insert FFC/FPC correctly all the way to the end. Design the proper layout of parts.
- ※ Make adjustments with the FFC/FPC manufacturer for bending performance and breakage.

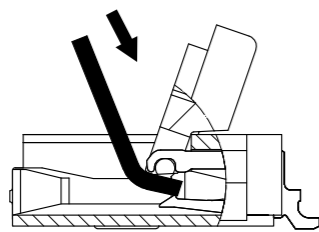

- 3. Do not rotate the actuator when FFC/FPC TAB is on right and left guides for positioning FFC/FPC.
Make sure the position of FFC/FPC TAB and guides before rotate the actuator.

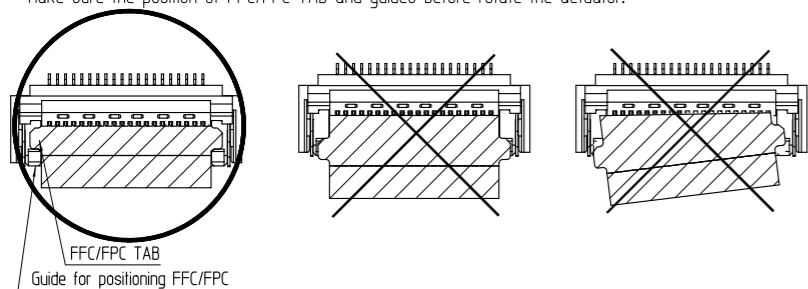

- ◆ Checking the Locking Condition
In the locked condition make sure that the actuator is horizontal on the board surface.
Do not apply excessive force to it near the 0° position of the actuator.
Otherwise the terminals may be deformed.

[INSTRUCTION ON FFC/FPC LAYOUT AFTER CONNECTOR]

- ◆ Load to FFC/FPC
Be very careful not to apply any force to the connector directly after inserting FFC/FPC. Otherwise the connector may become unlocked or the FFC/FPC may break.
In particular design the FFC/FPC layout with care not to bend it sharply upward in a vertical direction near the insertion opening.
Fix the FFC/FPC when loads are applied to it continuously.

Load: 0.1 x n N MAX
(n: number of contacts)

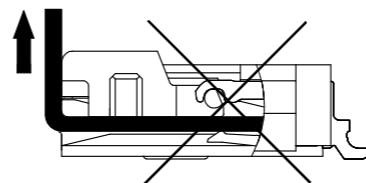

[INSTRUCTIONS ON REMOVING FPC]

- ◆ Move the actuator at approximately the center.
- ◆ Release the actuator to remove the FFC/FPC.
Remove the FFC/FPC by about 10 degrees along the surface.

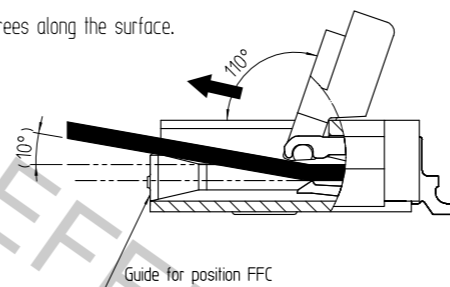

[OTHER INSTRUCTIONS]

- ◆ Instruction on Manual Soldering
Follow the instructions shown when soldering the connector manually during repair work, etc.
1. Do not perform reflow soldering or manual soldering with the FFC/FPC inserted into the connector.
2. Do not heat the connector excessively. Be very careful not to let the soldering iron contact any parts other than connector leads. Otherwise, the connector may be deformed or melt.
3. Do not use excessive solder (or flux).
if excessive solder (or flux) is used on the terminals, solder or flux may adhere to the contacts or rotating parts of the Actuator, resulting in poor contact or a rotation failure of the Actuator.
Supplying excessive solder to the reinforcing bracket may lock hinder Actuator, resulting in breakage of the connector.

<INSTRUCTION MANUAL(2)>

DRAWING NO.	PART NO.	TF31-**S-1SH(800)
HIROSE KOREA CO.,LTD.	CODE NO.	3
		5/5

X-ON Electronics

Largest Supplier of Electrical and Electronic Components

Click to view similar products for [FFC & FPC Connectors](#) category:

Click to view products by [Hirose](#) manufacturer:

Other Similar products are found below :

[FPH-1422G](#) [FPH-1602G](#) [K-FC20](#) [FH29B-80S-0.2SHW\(99\)](#) [FPH-2022G](#) [AYF332735](#) [52610-1075](#) [52610-1275](#) [52610-1934](#) [501864-3091-TR225](#) [086222026001800](#) [52610-0675](#) [62684-36210E9ALF](#) [52746-1671-TR250](#) [10051922-2810EHLF](#) [6-520415-9](#) [SFV6R-1STE9HLF](#) [XF3M-2915-1B-R100](#) [1658549-1](#) [AYF534065TA](#) [AYF351525](#) [086212040340800+](#) [AYF530365TA](#) [67000-014LF](#) [67000-004LF](#) [006207341915000+](#) [DS1020-19RT1D](#) [67000-003LF](#) [67000-011LF](#) [67000-016LF](#) [HFW14R-2STE9LF](#) [SFV32R-2STBE9HLF](#) [SFW12R-5STE9LF](#) [SFW18R-1STAE9LF](#) [SFW4R-5STE9LF](#) [52807-0430](#) [046283021002868+](#) [THD1015-8CL-SN](#) [67000-006LF](#) [502250-8027](#) [104267-9617](#) [66987-011LF](#) [AYF362535](#) [F0501-T-50-20T-R](#) [F1003-ZV-12-25T-R](#) [HFW8S-2STAE1HLF](#) [67000-008LF](#) [67000-012LF](#) [ECC576069EU](#) [F1002-B-20-20T-R](#)