



# 东莞市皇捷通讯科技有限公司

DONGGUAD HUANG JIE COMMUNI CAT ION TECHNOLOGY CO.,LTD.

3N0301LG-028

2.4GHz ISM Flexible Polymer

## Key Features

2.4 GHz ISM  
2400-2500 MHz

Embedded Antenna  
Wifi Antenna  
High Performance  
Ground Plane Independent  
Self-Adhesive

Dimensions 40.0 x 7.0mm  
ustomizable Cable and Connecto

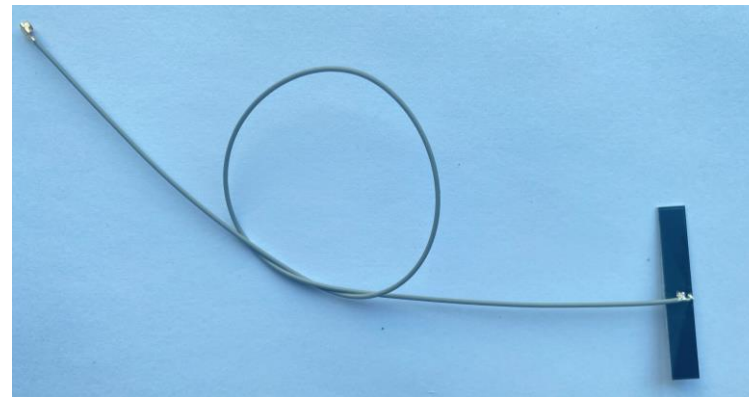

## Description

3N0301LG-028 antenna is flexible high efficiency embedded solution covering 2.4GHz. Antenna can be easily mounted in most devices due to self-adhesive layer and small size. 3N0301LG-028 is omnidirectional, ground plane independent antenna. Cable and connector is upon request.

东莞市皇捷通讯科技有限公司  
地址:广东省东莞市寮步镇泉塘大岷地工业区  
网址:www.iphone-line.com  
电话:0769-83328111      FAX:83327688





## Antenna and electrical specifications

Parameters	2.4GHz ISM Flexible Polymer
Standards	WIFI
Band (MHz)	2.4GHz
Frequency (MHz)	2400-2500 MHz
Return Loss (dB)	-15.6
VSWR	<2.0
Efficiency (%)	40-60
Peak Gain (dBi)	2
Impedance (Ohm)	50
Polarisation	Linear
Radiation Pattern	Omni-Directional
Max. Input Power (W)	25
Connector Type	Most RF Connectors (U.FL Standard)
Cable Length	Any Cable Length (345mm Standard)
Cable Type	Other Cables Available (1.13mm Standard)

### Antenna Measurement Conditions:

Mounted 40x10x0.3 Cm ABS Plastic Plate

Measured in Certified CTIA 3DAnechoic Chamber



## Mechanical and environmental specifications

Specifications	3N0301LG-028
Mounting Type	Self-Adhesive
Dimensions (mm)	40.0 x 7.0mm
Adhesive Type	3M
Material	Flexible Polymer
Operating Temperature (C)	-40 to +85
Storage Temperature (C)	-40 to +85
Substance Compliance	RoHS

REVISION	DESCRIPTION	DATE	DRAFTER
A0	FIRST RELEASE	19.05.28	XIU HE
A1	增加手撕位置	20.01.08	Mark

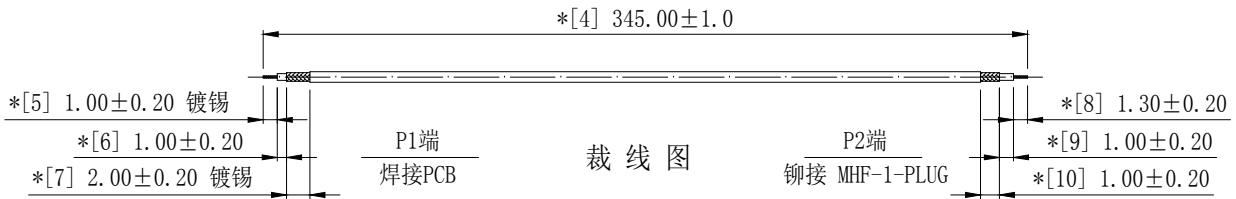
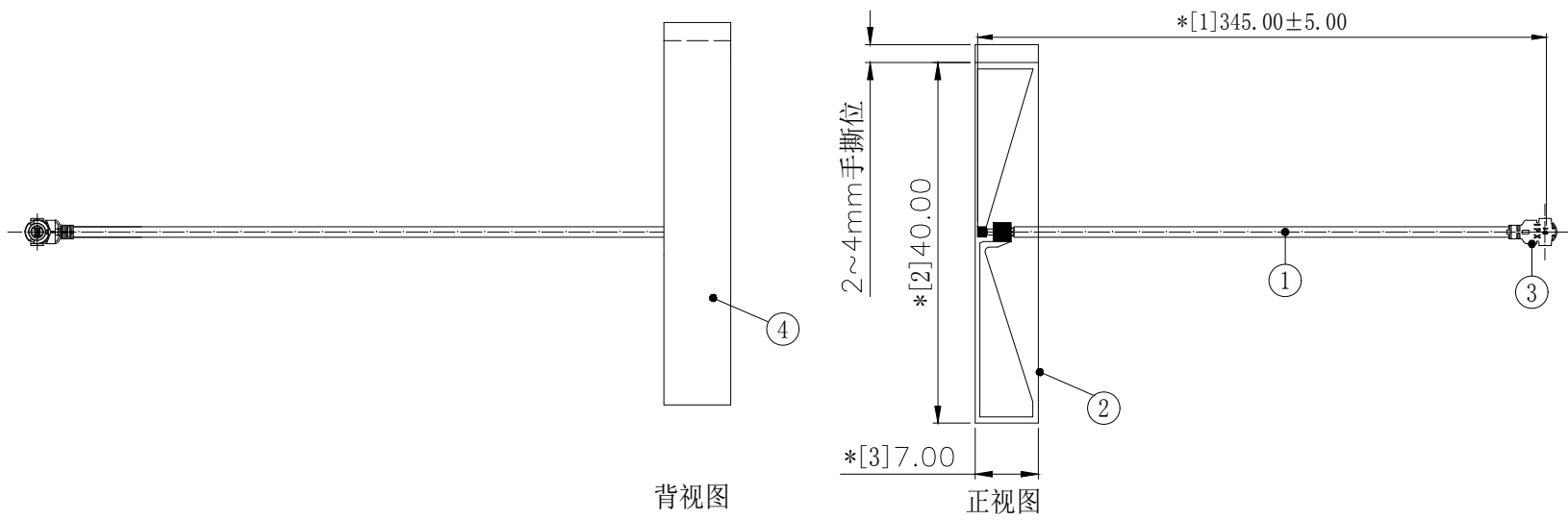

技术要求:

- 方向要求: 无
- 电气特性: 特性阻抗:50Ω; 频率范围:2.40GHz-2.50GHz; 驻波比:最大2.0;。  
检验方法: 单测天线, 使用网络分析仪100%比对Gold sample波形测试。
- 尺寸检验: [\*]为FAI检测项目; \*为重点检测项目; ■为CPK管制项目。
- 外观检验: 电缆裁切须平整, 镀锡须光亮, 导体不得有多余股数伸出与散乱;  
PCB不得有划痕、刮伤、露铜等不良, 焊接须饱满, 不得有假焊、虚焊、毛刺;  
电缆外被不得有破损、折皱及异色等不良。  
检验方法: 目视全检。
- 包装规范: 20PCS/扎, 5扎/包, 即100PCS/包。
- 环保要求: 产品及其使用之物料皆需要符合RoHS要求。

4	2MH058	EVA+双面背胶, L40*W7.0*T1.0 mm, 手撕位长3mm	1	---
3	2LM10P113210	MHF-1-PLUG FOR OD1.13 CABLE	1	---
2	2YP062	PCB ANTENNA L40.0*W7.00*T0.60mm, 黑色	1	---
1	2C5M11312LG1	微细同轴电缆, OD1.13, 双锡线, 浅灰色	1	依裁线图裁线
No.	PART NUMBER	PART NAME & DESCRIPTION	Q' TY	REMARKS

GENERAL TOLERANCE:  
LINEAR:  
X ±1.00  
X.X ±0.50  
X.XX ±0.30  
X.XXX ±0.20  
ANGLE:  
X° ±4.00°  
X.X° ±3.00°  
X.XX° ±2.00°  
X.XXX° ±1.00°

HJ-Tech		东莞市皇捷通讯科技有限公司		
FILE NAME: 产品图	TITLE: 射频天线组件 内置天线, OD1.13, 浅灰双锡线; P1端焊接PCB; P2端打一代端子; 裁线长L=345mm			
ENG/DATE: XIU HE/19.05.28	P/N: 3N0301LG-028			
CHE/DATE:	UNIT: mm	SCALE: 1:1	REVISION: AO	SHEET: 1/1
APP/DATE:				

COMPLIANCE WITH THE REQUIREMENT: ■RoHS; □HF; □SONY SS-00259; □OTHERS  
\*NO USING ESTRICED AND BANNED SUBSTANCE

# 实物照片

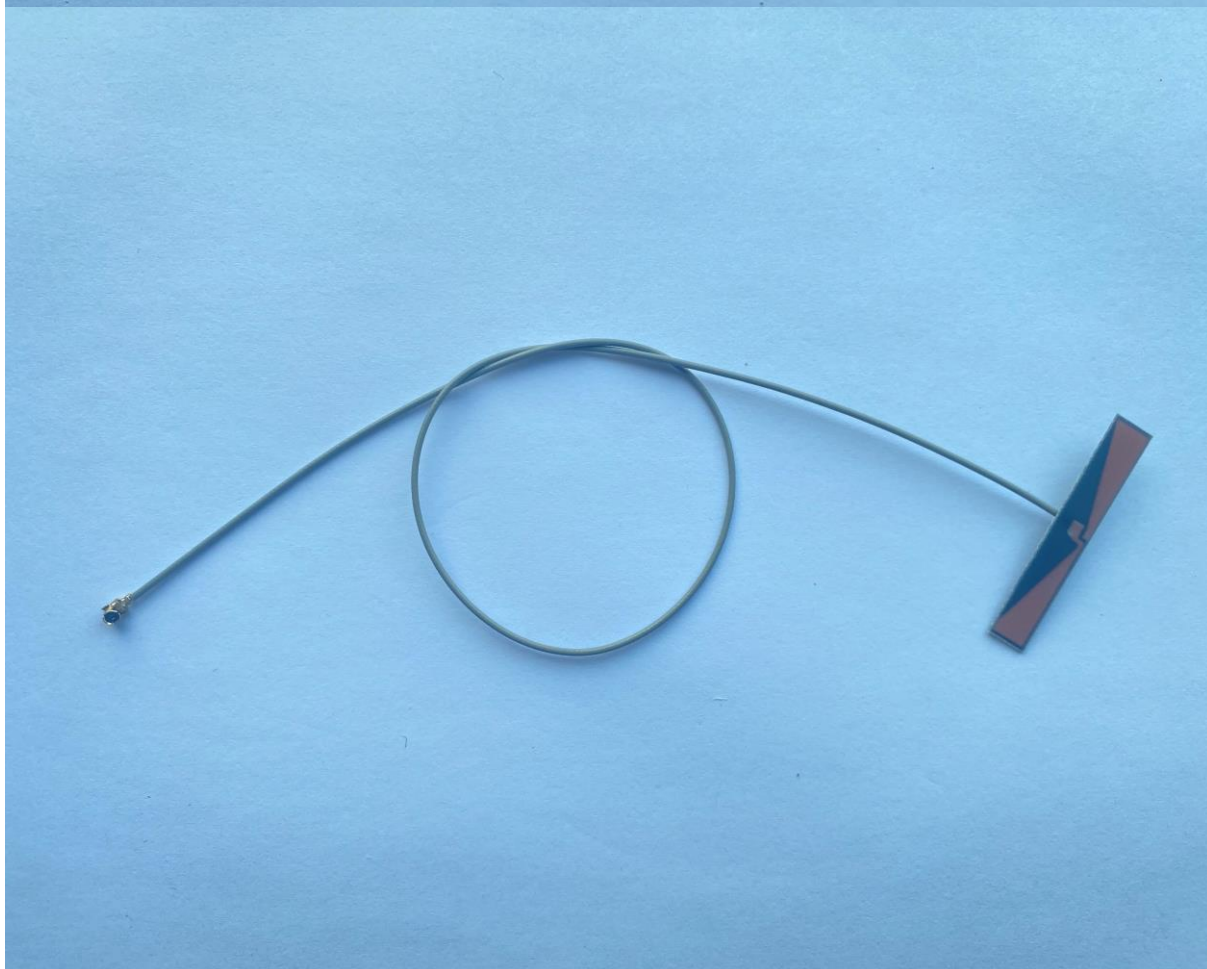
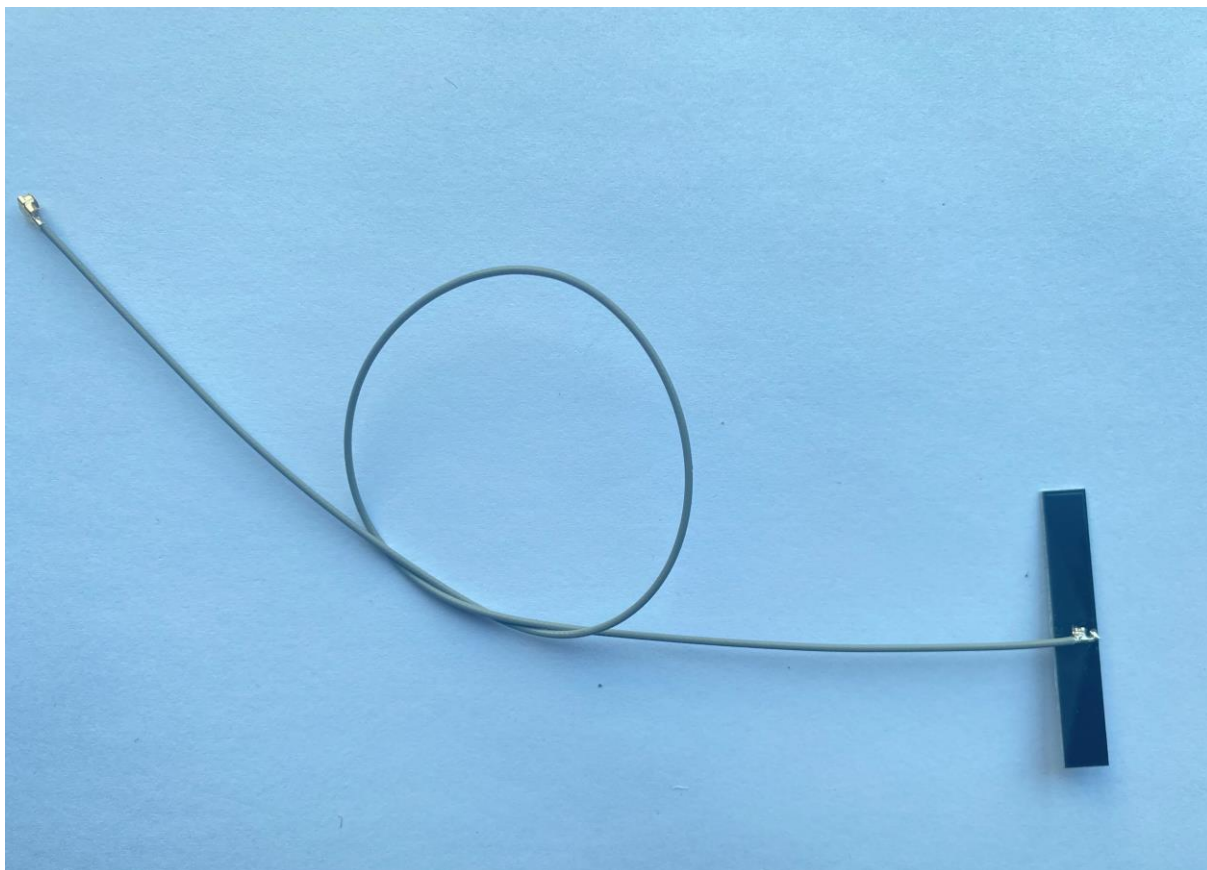



# 天线电气特性测试报告

## Antenna Electrical Characteristic Test Report

文件编号:HJ-QR-Q-22 Rev:A0

产品料号 Part Number:	3N0301LG-028	测试项目 Item	规格 Spec	结果判定 Judge
产品名称 Part Name:	内置天线,OD1.13,双锡线,浅灰色; P1端焊接PCB;P2端打一代端子;裁线长 L=345mm	VSWR 驻波比	≤2.0	pass
测试设备 Test Equipment	网络分析仪/微波暗室	Characteristic impedance 特征阻抗	50Ω	pass
数量 Quantity	5pcs	Gain 增益	2dBi	pass
测试日期 Test Date	2019/5/23			

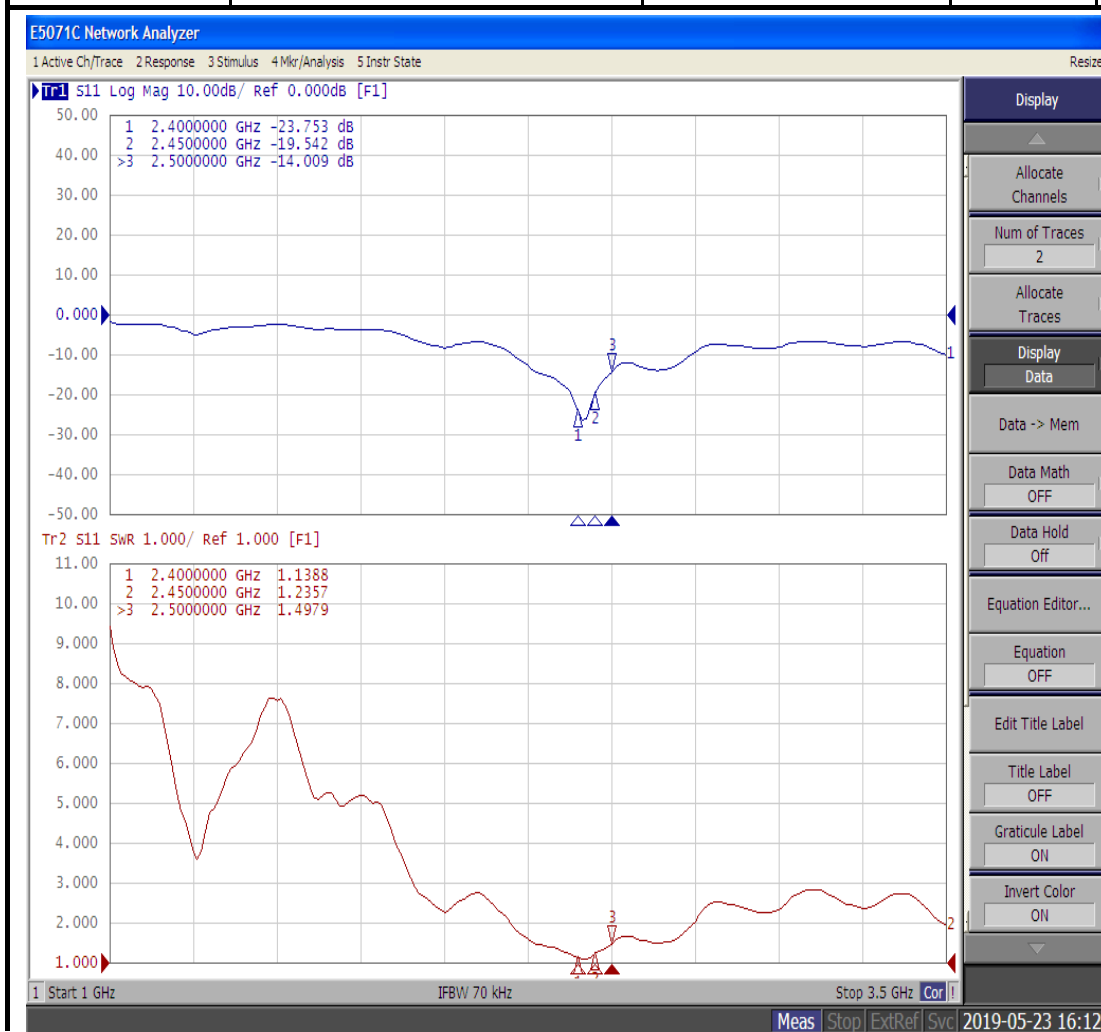

Frequency ID	1	2	3	4	5	6	7	8	9	10	11
Frequency (MHz)	2400.0	2410.0	2420.0	2430.0	2440.0	2450.0	2460.0	2470.0	2480.0	2490.0	2500.0
Point Values											
Ant. Port Input Pwr. (dBm)	0.00	0.00	0.00	0.00	0.00	0.00	0.00	0.00	0.00	0.00	0.00
Tot. Rad. Pwr. (dBm)	-2.96	-3.04	-2.96	-2.66	-2.60	-2.53	-2.44	-2.23	-2.35	-2.38	-2.33
Peak EIRP (dBm)	0.96	0.75	0.96	1.52	1.52	1.29	1.30	1.68	1.59	1.82	1.79
Directivity (dBi)	3.92	3.79	3.92	4.18	4.12	3.82	3.74	3.91	3.94	4.20	4.12
Efficiency (dB)	-2.96	-3.04	-2.96	-2.66	-2.60	-2.53	-2.44	-2.23	-2.35	-2.38	-2.33
Efficiency (%)	50.60	49.60	50.60	54.20	54.90	55.90	57.00	59.90	58.20	57.80	58.50
Gain (dBi)	0.96	0.75	0.96	1.52	1.52	1.29	1.30	1.68	1.59	1.82	1.79

审核Checker: 王俊

测试者Tester: Mark

产品料号

3N0301LG-028

产品名称

2.4GHz 天线

### Radiation

2400.00MHz@T45P45

2400 MHz

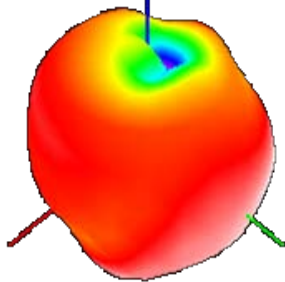

X Axis  
Y Axis  
Z Axis

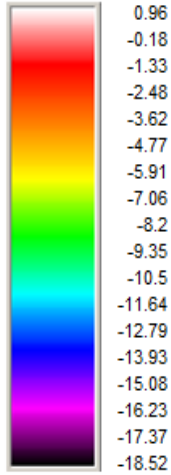

### 2400 MHz H

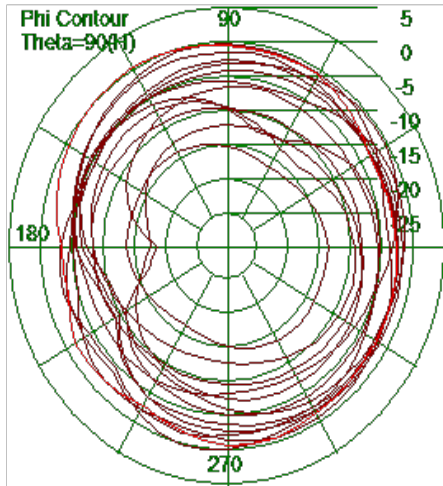

### 2400 MHz E1

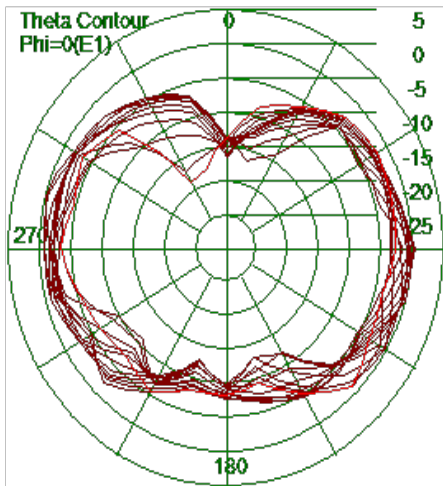

### 2400 MHz E2

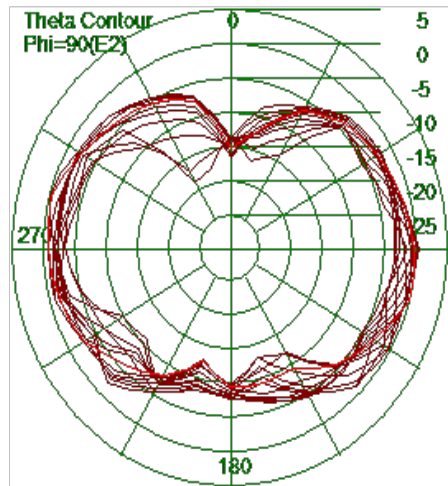

审核Checker: 王俊

测试者Tester: Mark



产品料号

3N0301LG-028

产品名称

2.4GHz 天线

### Radiation

2450.00MHz@T45P45

2450 MHz

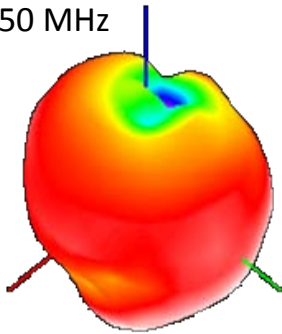

X Axis  
Y Axis  
Z Axis



1.29  
0.22  
-0.84  
-1.91  
-2.97  
-4.04  
-5.11  
-6.17  
-7.24  
-8.3  
-9.37  
-10.44  
-11.5  
-12.57  
-13.63  
-14.7  
-15.77  
-16.83

2450 MHz H

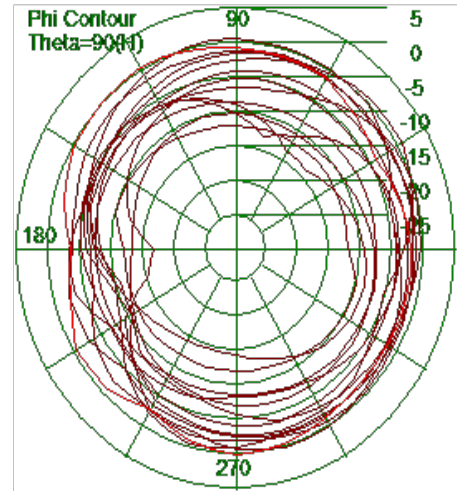

2450 MHz E1

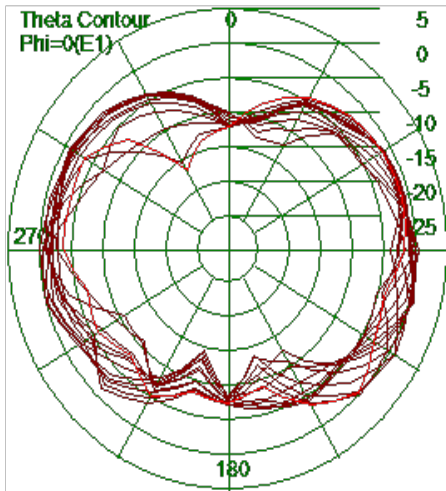

2450 MHz E2

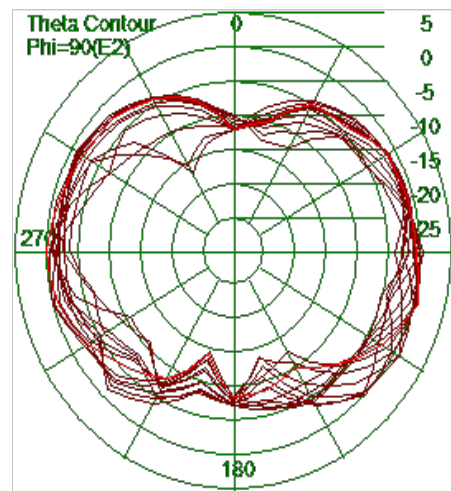

审核Checker: 王俊

测试者Tester: Mark



产品料号

3N0301LG-028

产品名称

2.4GHz 天线

### Radiation

2500.00MHz@T45P45

2500 MHz

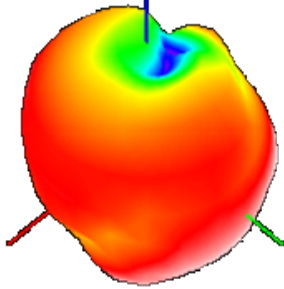

X Axis  
Y Axis  
Z Axis

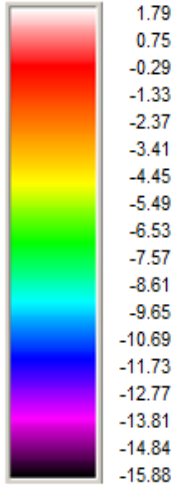

### 2500 MHz H

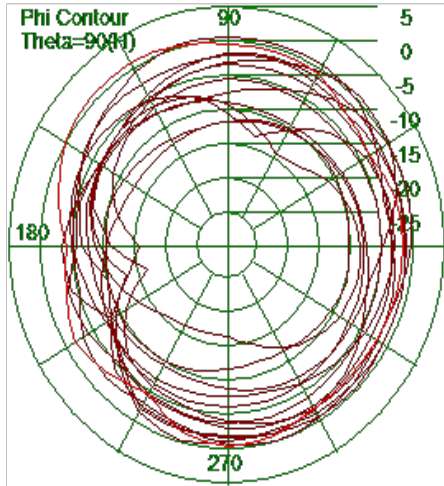

### 2500 MHz E1

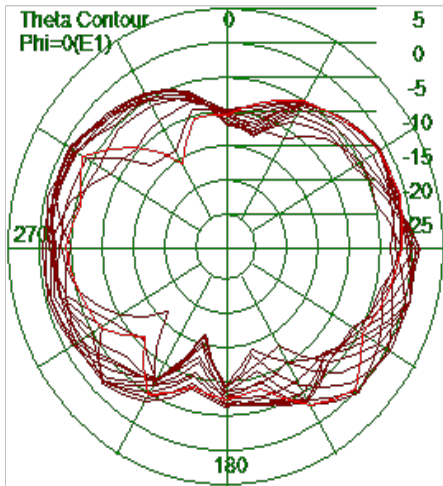

### 2500 MHz E2

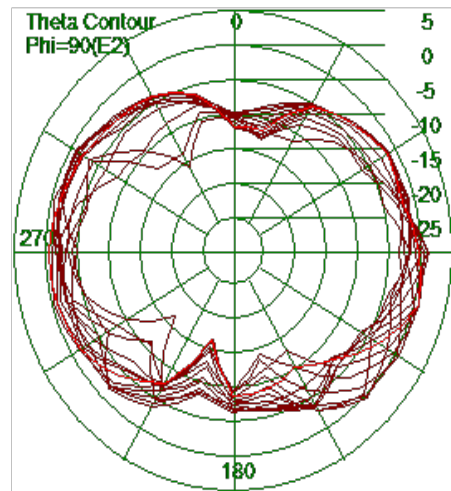

审核Checker: 王俊

测试者Tester: Mark

## X-ON Electronics

Largest Supplier of Electrical and Electronic Components

*Click to view similar products for [Antennas](#) category:*

*Click to view products by [HJ Technology](#) manufacturer:*

Other Similar products are found below :

[GAN30084EU](#) [930-033-R](#) [EXE902SM](#) [APAMPG-117](#) [MAF94383](#) [W6102B0100](#) [SPDA17RP918](#) [A09-F5NF-M](#) [RGFRA1903041A1T](#) [108-00016-050](#) [W3921B0100](#) [SIMNA-868](#) [SIMNA-915](#) [SIMNA-433](#) [W1049B090](#) [TRABT1560](#) [A75-001](#) [W3118A](#) [WTL2449CQ1-FRSMM](#) [CPL9C](#) [0600-00060](#) [GD5W-28P-NF](#) [MA9-7N](#) [GD53-25](#) [C37](#) [MAF94051](#) [FRX380](#) [MA9-5N](#) [B1322NR](#) [QWFTB120](#) [MAF94271](#) [MAF94300](#) [GPSMB301](#) [FG4403](#) [PSQ24495-91RSM](#) [MIKROE-2393](#) [DA5-32RADOME](#) [5200227](#) [GPSCPMM00](#) [W1049B030](#) [SPDA17RP918](#) [GPSCP00](#) [AN 303](#) [ANTDOM-05-01-WPM](#) [EXW30BNX](#) [OSCAR1A/5M/SMAM/S/S/31](#) [ALPHA4A/1M/SMAM/S/S/26](#) [OSCAR1A/10M/SMAM/S/S/31](#) [OSCAR40/5M/LL/SMAM/S/S/33](#) [OSCAR40/10M/LL/SMAM/S/S/33](#)