



Part number	L0(μH) Inductance ±20% @0A(μH)	Rdc (mΩ) @25°C		Heat Rating Current DC Amps. Idc (A)	Saturation Current DC Amps Isat (A)
		Typ.	Max.		
MCW-0650-R13-N2	0.10	1.0	1.2	42.0	48.0
MCW-0650-R22-N2	0.22	1.1	1.3	30.0	35.0
MCW-0650-R36-N2	0.36	2.7	3.1	21.0	25.0
MCW-0650-R40-N2	0.40	3.2	3.5	20.0	23.0
MCW-0650-R47-N2	0.47	3.4	3.8	20.0	21.0
MCW-0650-R56-N2	0.56	3.4	3.6	20.0	18.0
MCW-0650-R68-N2	0.68	3.9	4.2	18.0	16.0
MCW-0650-R82-N2	0.82	4.6	4.9	16.5	17.0
MCW-0650-1R0-N2	1.00	5.6	6.5	12.0	13.0
MCW-0650-1R2-N2	1.20	6.2	7.5	11.0	12.0
MCW-0650-1R5-N2	1.50	7.8	9.0	10.0	11.0
MCW-0650-2R2-N2	2.20	11.2	12.5	9.5	10.0
MCW-0650-3R3-N2	3.30	18.0	20.9	8.5	9.0
MCW-0650-4R7-N2	4.70	26.0	29.0	6.0	8.0
MCW-0650-5R6-N2	5.60	31.5	34.4	6.0	7.0
MCW-0650-6R8-N2	6.80	35.0	40.0	5.5	7.0
MCW-0650-8R2-N2	8.20	40.0	43.0	5.5	6.5
MCW-0650-100-N2	10.00	54.0	60.0	4.5	6.0
MCW-0650-120-N2	12.00	58.0	65.0	4.0	5.0
MCW-0650-150-N2	15.00	78.0	85.0	3.1	4.0
MCW-0650-180-N2	18.00	83.0	105.0	3.0	3.5
MCW-0650-220-N2	22.00	120.0	140.0	2.6	3.5
MCW-0650-330-N2	33.00	160.0	200.0	2.3	3.0
MCW-0650-470-N2	47.00	250.0	290.0	2.0	2.8

※Note:

- All test data is reference to 25°C ambient.
- Test Condition: 100KHz, 1.0Vrms
- Idc: DC current (A) that will cause an approximate ΔT of 40°C
- Isat : DC current (A) that will cause L0 to drop approximately 30%
- Operat between temperature range -55°C to +125°C

The part temperature (ambient + temp rise) should not exceed 125°C under the worst case operating conditions.Circuit design, component.PWB trace size and thickness, airflow and other cooling provision all affect the part temperature.Part temperature should be verified in the end application.

- The rated current as listed is either the saturation current or the heating current depending on which value is lower.

※ Regulation of Part number

$$\begin{matrix} \text{MC} & \text{W} & = & \text{0650} & = & \text{2R2} & = & \text{N} & \text{2} \\ \text{①} & \text{②} & & \text{③} & & \text{④} & & \text{⑤} & \text{⑥} \end{matrix}$$

- ① Molding Choke;
- ② Mold Categories:W;
- ③ Dimensions(unit:mm):6.0x6.0x5.0;

- ④ Inductance Value:2R2=2.2μH;
- ⑤ The Material Code;
- ⑥ Material Type;

※ Features

- High performance (Isat) realize by metal dust core.
- Low profile:Thickness max.5.0mm
- Low loss and low resistance
- Capable of corresponding high frequency (1MHz)
- 100% lead (Pb) free meet RoHS sta



※ Application

- DC/DC converters for laptop motherboards/CPU
- Thin type of on-board power supply module for Voltage regulator VRM for server

※ Dimensions in inches (unit:mm)

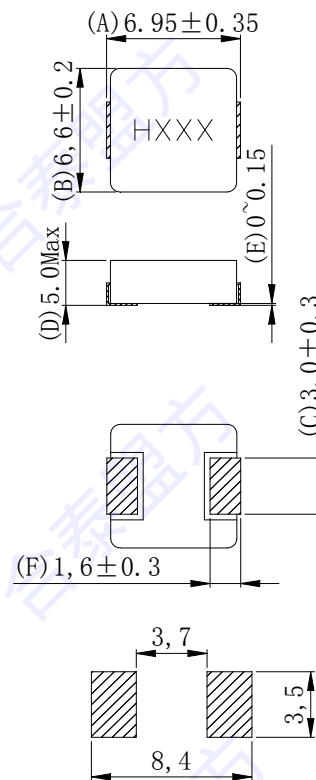

Suggested pad layout
Dimensions are in mm

X-ON Electronics

Largest Supplier of Electrical and Electronic Components

Click to view similar products for [Fixed Inductors](#) category:

Click to view products by [Hk-hotline](#) manufacturer:

Other Similar products are found below :

[CR32NP-151KC](#) [CR32NP-180KC](#) [CR32NP-181KC](#) [CR32NP-1R5MC](#) [CR32NP-390KC](#) [CR32NP-3R9MC](#) [CR32NP-680KC](#) [CR32NP-820KC](#) [CR32NP-8R2MC](#) [CR43NP-390KC](#) [CR43NP-560KC](#) [CR43NP-680KC](#) [CR54NP-181KC](#) [CR54NP-470LC](#) [CR54NP-820KC](#) [CR54NP-8R5MC](#) [70F224AI](#) [MGDQ4-00004-P](#) [MHL1ECTTP18NJ](#) [MHQ1005P10NJ](#) [MHQ1005P1N0S](#) [MHQ1005P2N4S](#) [MHQ1005P3N6S](#) [MHQ1005P5N1S](#) [MHQ1005P8N2J](#) [PE-51506NL](#) [PE-53601NL](#) [PE-53602NL](#) [PE-53630NL](#) [PE-53824SNLT](#) [PE-92100NL](#) [PG0434.801NLT](#) [PG0936.113NLT](#) [9220-20](#) [9310-16](#) [PM06-2N7](#) [PM06-39NJ](#) [A01TK](#) [1206CS-471XJ](#) [HC2LP-R47-R](#) [HC2-R47-R](#) [HC3-2R2-R](#) [HCF1305-3R3-R](#) [1206CS-151XG](#) [RCH664NP-140L](#) [RCH664NP-4R7M](#) [RCH8011NP-221L](#) [RCP1317NP-332L](#) [RCP1317NP-391L](#) [RCR1010NP-470M](#)