

Standard No.	Revision code	Designation of standard	Page
CR-D-8049		Product standard	1/19

## Contents

1. Scope .....	2
2. Relevant documents .....	2
3. Model designation .....	2
4. Ratings .....	2
5. Appearance and marking .....	5
6. Performance .....	6
7. Packing .....	11
8. Packing specifications .....	15
9. Operating instructions .....	17
10. Industrial property rights .....	19
11. Other .....	19

Standard No.	Revision code	Designation of standard	Page
CR-D-8049		Product standard	2/19

## 1. Scope

This standard is applied to the corner type High Voltage CR HCR Type series.

## 2. Relevant documents

JIS C 5201 Common Rules for Fixed Resistors for Electronics Equipment  
 JIS C 5201-1 Method of Testing Fixed Resistors for Electronics Equipment  
 JIS C 0806 Taping of Electronics Parts (Surface Mounting Devices)

## 3. Model designation

A model designation shall be composed as follows:

$\frac{\text{HCR32}}{(1)} - \frac{305}{(2)} \frac{\text{J}}{(3)} \frac{\text{V}}{(4)}$

(1) shall represent the designation of the article. (See clause 4-1.)

(2) shall represent the nominal resistance. (See clause 4-5.)

(3) shall represent the resistance allowance. (See clause 4-6.)

(4) shall represent the form of packing. (For details, see clause 7.)

Code	Form of packing
V	Paper taping
B	Bulk

## 4. Ratings

### 4-1. Rated power: The rated power shall be as follows:

Article designation	Rated power (W)	Resistance allowance	Resistance range ( $\Omega$ )	Temperature coefficient at zeroth order of the resistance (ppm/ $^{\circ}\text{C}$ )	Maximum operating voltage (V)	Maximum overload voltage (V)
HCR32	0.250	F( $\pm 1\%$ )	160k~20M	$\pm 200$	500	1000
		J( $\pm 5\%$ )	160k~20M			

### 4-2. Operating temperature range

-55 $^{\circ}\text{C}$  to 125 $^{\circ}\text{C}$

### 4-3. Maximum power (maximum current)

With the rated ambient temperature set to 70 $^{\circ}\text{C}$ , the maximum power (the maximum current for a 0 $\Omega$  product) at a temperature of no more than the rated ambient temperature shall be equal to the rated power. The maximum power at a temperature exceeding the rated ambient temperature shall be a value determined by reducing the rated power according to the power reduction curve on the right-hand figure.

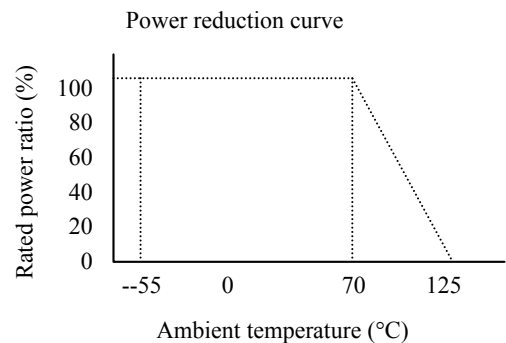

Standard No.	Revision code	Designation of standard	Page
CR-D-8049		Product standard	3/19

#### 4-4. Rated voltage

The rated voltage shall be the DC or AC (effective power frequency) voltage corresponding to the rated power and shall be determined with the formula given below. However, if the determined rated voltage exceeds the maximum operating voltage specified in clause 4-1, that maximum operating voltage shall be the rated voltage.

$$E = \sqrt{P \times R}$$

E: Rated voltage (V)  
P: Rated power (W)  
R: Nominal resistance ( $\Omega$ )

#### 4-5. Nominal resistance

The nominal resistance shall be in ohms ( $\Omega$ ), and shall be  $10^n$  times (n is an integer) the value in the sequences E24 and E96 in the table below.

Sequence E24											
1.0	1.1	1.2	1.3	1.5	1.6	1.8	2.0	2.2	2.4	2.7	3.0
3.3	3.6	3.9	4.3	4.7	5.1	5.6	6.2	6.8	7.5	8.2	9.1

#### 4-6. Resistance allowance

The resistance allowance shall come in the two values shown below. The combinations of the standard value of nominal resistance and resistance allowance shall be as in the table below.

Resistance allowance	Code	Standard value of nominal resistance
$\pm 1\%$	F	Sequence E24
$\pm 5\%$	J	

Standard No.	Revision code	Designation of standard	Page
CR-D-8049		Product standard	4/19

#### 4-7. Structural diagram

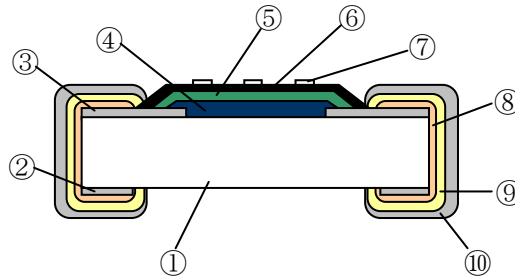

Code	Designation of component	Material
①	Ceramics board	Alumina 96%
②	Rear electrode	Glass-based Ag
③	Surface electrode	Glass-based Ag-Pd
④	Resistor	Based on ruthenium oxide
⑤	Protective coat I	Glass-based
⑥	Protective coat II	Resin-based
⑦	Stamp	Resin -based
⑧	Side electrode	Resin -based Ag
⑨	Internal electrode	Ni plated (plating 2-12 $\mu$ m thick)
⑩	External electrode	Sn plating (Sn 100%) (plating 2-12 $\mu$ m thick)

#### 4-8. Dimensions

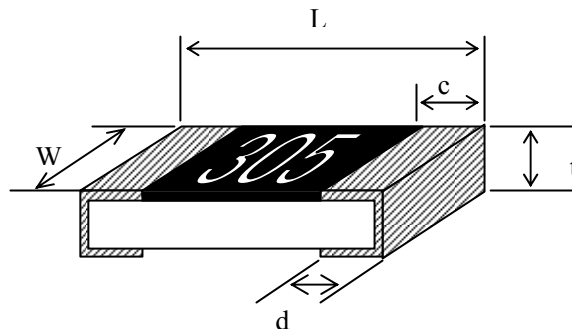

[mm]

Form of packing	Article	L	W	c	d	t
Taped bulk	HCR32	3.2 $\pm$ 0.10	1.6 $\pm$ 0.10	0.5 $\pm$ 0.2	0.5 $\pm$ 0.2	0.50 $\pm$ 0.10

Standard No.	Revision code	Designation of standard	Page
CR-D-8049		Product standard	5/19

## 5. Appearance and marking

### 5-1. Appearance

All products shall be free of considerable scratches, cracks, and other anomalies when visually tested.

### 5-2. Product marking

All products shall be marked with their nominal resistance values, as described in the table below.

Location of marking	Overcoat top of resistor			
Marking color	White			
Method of marking	Marking in 3 digits (E24) The first two numbers shall be effective numbers in ohms ( $\Omega$ ). The third digit shall represent the number of zeros following the effective numbers.  $3M\Omega$ <table border="1" style="display: inline-table; vertical-align: middle;"><tr><td style="width: 15px; height: 15px;"></td><td style="width: 15px; height: 15px; text-align: center;">305</td><td style="width: 15px; height: 15px;"></td></tr></table>		305	
		305		
Application: HCR32  (1) Decimal points shall be represented in Rs. In this case, all shall be effective numbers. (2) Marking of classes F and D  <table border="1" style="margin-left: auto; margin-right: auto;"> <tr> <td>Article</td> <td>Sequence E24</td> </tr> <tr> <td>HCR32</td> <td>Marking in 3 digits</td> </tr> </table>	Article	Sequence E24	HCR32	Marking in 3 digits
Article	Sequence E24			
HCR32	Marking in 3 digits			

Standard No.	Revision code	Designation of standard	Page
CR-D-8049		Product standard	6/19

## 6. Performance

### 6-1. Electric performance

Electric performance shall satisfy the requirements specified in the table below. The test method shall be as per JIS C 5201-1.

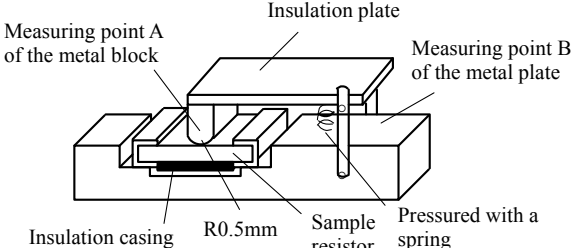
No.	Item	Performance	Test method (JIS C 5201-1)	
1	Resistance	Within specified resistance allowance	As per 4.5.	
			Range of nominal resistance ( $\Omega$ )	Maximum voltage applied (V)
			160k or more	Less than 20M
2	Temperature coefficient at zeroth order of the resistance	As per clause 4-1	As per 4.8. The sample resistance shall be attached to the test board B. The test condition shall be condition B.	
3	Overload	Shall be free of considerable appearance anomalies and shall be legible. $\Delta R/R \pm (2.5\%+0.1\Omega)$	The sample resistance shall be attached to the test board B. A voltage of twice the limiting element voltage shall be applied for 2 seconds. The maximum overload voltage and rated current shall be as per clause 4-1 of this standard.	
4	Insulation resistance	- Between the electrodes and insulation board: 1000M $\Omega$ or more	<p>As per 4.13.</p> <p>The test shall consist of taking measurements between the electrodes and insulation casing of the sample resistor and between the electrodes and insulation board of the sample resistor when a test voltage is applied to a unit as illustrated in the diagram between the measuring point A of the metal block (positive electrode) and the measuring point B of the metal plate.</p> <p>The sample resistor shall be placed in the groove in the metal plate, with the insulation casing facing downwards or upwards so that the tip of the metal block will come to about the middle between the electrodes of the sample resistor. The metal resistor shall then be pressured at <math>1.0\pm 0.2N</math> {<math>0.102\pm 0.021kgf</math>}.</p> <p>The test voltage shall be a DC voltage of <math>100\pm 15V</math>. After it is held for about 1 minute, the sample shall be measured with that voltage applied to it. However, if the meter reading stabilizes or it exceeds the specified insulation resistance and goes further up, measurements may be taken before a specified time is reached.</p> 	

Standard No.	Revision code	Designation of standard	Page
CR-D-8049		Product standard	7/19

No.	Item	Performance	Test method (JIS C 5202)				
5	Dielectric strength	<ul style="list-style-type: none"> <li>- Between the electrodes and insulation casing</li> <li>- Between the electrodes and insulation board</li> </ul> <p>There shall be no flashover, burn, dielectric breakdown, or other anomaly.</p>	<p>As per 4.6.</p> <p>The test shall consist of applying a test voltage between the measuring points A and B with the same unit and method of installation as in the test on insulation resistance and taking measurements between the electrodes and insulation casing and between the electrodes and insulation board of the sample resistor. Before the test, measure the resistance.</p> <p>The test voltage shall be an AC voltage (effective power frequency) and shall be as follows:</p> <table border="1" style="margin-left: 20px;"> <thead> <tr> <th>Article</th> <th>Voltage (V)</th> </tr> </thead> <tbody> <tr> <td>HCR32</td> <td>500</td> </tr> </tbody> </table> <p>Voltage shall be applied by increasing it gradually from about 0V to 100V in a second and, after the voltage reaches a specified level, holding it for 1 minute <math>\pm_{0}^{10}</math> seconds, then reducing the voltage gradually to about 0V. The power capacity of the AC power shall not be applied. After the test, the resistance shall be measured.</p>	Article	Voltage (V)	HCR32	500
Article	Voltage (V)						
HCR32	500						

Standard No.	Revision code	Designation of standard	Page
CR-D-8049		Product standard	8/19

## 6-2. Mechanical performance

The mechanical performance shall satisfy the requirements specified in the table below. The test method shall be as per JIS C 5201-1.

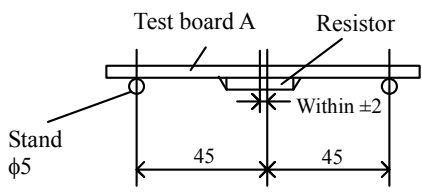
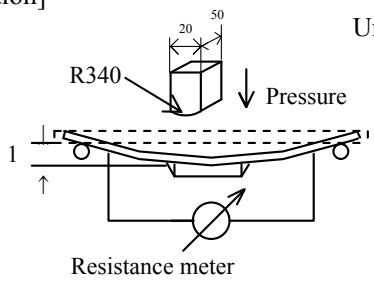
No.	Item	Performance	Test method (JIS C 5201-1)
1	Electrode strength	There shall be no mechanical damage. $\Delta R/R \pm (1\%+0.1\Omega)$	<p>As per 4.33. The sample resistor shall be installed on the test board A. The center of the sample resistor shall be within <math>\pm 2\text{mm}</math> from the center of the stand.</p> <p>The test board A shall, as shown in the figure, be supported at 45mm respectively from the center. The center shall be pressured at a rate of 1mm per second with a pressure jig until its bend width is 1mm. While it is held for <math>5\pm 1</math> seconds, its resistance shall be measured.</p> <p>[Installed condition]</p> <p style="text-align: right;">Unit: mm</p>  <p>[Test condition]</p> <p style="text-align: right;">Unit: mm</p>  <p>Remark: The pressure jig and stand shall as a rule be made of quenched steel (hardness: HB 183-255) or carbide (Rockwell HRA 90 or more).</p>
2	Heat resistance of solder	Shall be free of considerable appearance anomalies and shall be legible. $\Delta R/R \pm (1\%+0.1\Omega)$	<p>As per 4.18. The solder temperature shall be <math>260\pm 5^\circ\text{C}</math>. The solder shall be dipped for <math>10\pm 1</math> seconds. The entire sample resistor shall be dipped in the flux and solder. After it is dipped in the solder, the sample shall be left at room temperature for at least an hour and then its resistance shall be measured.</p>
3	Solderability	95% of the surface area of the electrodes shall be covered with new solder.	<p>As per 4.17. The solder temperature shall be <math>235\pm 5^\circ\text{C}</math>. The dip time shall be <math>2\pm 0.5</math> seconds. The entire sample resistor shall be dipped in flux and solder. The inspection tools shall consist of a projector or a magnifier with a magnification of 10X.</p>
4	Solvent resistance	The sample shall be free of considerable appearance anomalies and shall be legible.	<p>As per 4.29. The sample resistor shall be installed on the test board B. The solvent shall be isopropyl alcohol. The sample shall be dipped in a solvent at <math>20\text{-}25^\circ\text{C}</math> for <math>60\pm 10</math> seconds. It shall be left at room temperature for 5 minutes. The stamp impression shall then be rubbed with cotton.</p>



Standard No.	Revision code	Designation of standard	Page
CR-D-8049		Product standard	9/19

### 6-3. Weatherproofness

The weatherproofness of the products shall satisfy the requirements specified in the table below. The test method shall be as per JIS C 5201-1.

No.	Item	Performance	Test method (JIS C 5201-1)												
1	Temperature cycle	The sample shall be free of considerable appearance anomalies and shall be legible. $\Delta R/R \pm (1\%+0.05\Omega)$	As per 4.19. The sample resistor shall be installed on the test board B. The test temperatures shall be in the sequence specified in the table. <table border="1" data-bbox="842 568 1377 703"> <tr> <td>1</td> <td>-55±3°C</td> <td>30 minutes</td> </tr> <tr> <td>2</td> <td>Room temperature</td> <td>2-3 minutes</td> </tr> <tr> <td>3</td> <td>+125±2°C</td> <td>30 minutes</td> </tr> <tr> <td>4</td> <td>Room temperature</td> <td>2-3 minutes</td> </tr> </table> The cycles 1 through 4 shall be repeated five times.	1	-55±3°C	30 minutes	2	Room temperature	2-3 minutes	3	+125±2°C	30 minutes	4	Room temperature	2-3 minutes
1	-55±3°C	30 minutes													
2	Room temperature	2-3 minutes													
3	+125±2°C	30 minutes													
4	Room temperature	2-3 minutes													
2	Durability (moisture resistance load)	The sample shall be free of considerable appearance anomalies and shall be legible. $\Delta R/R \pm (5\%+0.1\Omega)$	As per 4.24. The sample resistor shall be installed on the test board B. The test temperature shall be 40±2°C, with a temperature between 90 and 95%RH. The cycle of keeping the rated voltage on for 90 minutes and off for 30 minutes shall be repeated for $1000 \pm \begin{smallmatrix} 48 \\ 0 \end{smallmatrix}$ .												
3	Durability (rated load)	The sample shall be free of considerable appearance anomalies and shall be legible. $\Delta R/R \pm (5\%+0.1\Omega)$	As per 4.25. The sample resistor shall be installed on the test board B. The test temperature shall be 70±2°C. The cycle of keeping the rated voltage on for 90 minutes and off for 30 minutes shall be repeated for $1000 \pm \begin{smallmatrix} 48 \\ 0 \end{smallmatrix}$ . However, the voltage applied shall not exceed the maximum voltage.												
4	Stability	$\Delta R/R \pm (5\%+0.1\Omega)$	As per 4.23. The sample resistor shall be installed on the test board B. The sample shall be left in a constant-temperature tank at 125±3°C for $1000 \pm \begin{smallmatrix} 48 \\ 0 \end{smallmatrix}$ hours. It shall be left at room temperature for at least 1 hour, and its resistance shall be measured.												
5	Moisture resistance (steady state)	$\Delta R/R \pm (5\%+0.1\Omega)$	As per 4.24. The sample resistor shall be installed on the test board B. The sample shall be left unloaded at 40±2°C and 90-95%RH for $1000 \pm \begin{smallmatrix} 48 \\ 0 \end{smallmatrix}$ hours. It shall be left at room temperature for at least 1 hour, and its resistance shall be measured.												

Standard No.	Revision code	Designation of standard	Page
CR-D-8049		Product standard	10/19

#### 6-4. Test board

##### 6-4-1. Board A (HCR32)

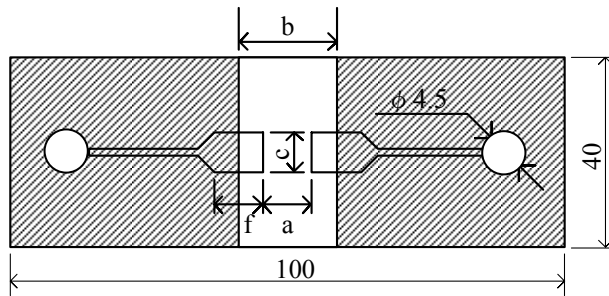

Material: Glass epoxy resin  
Board thickness: 1.6mm  
Copper foil thickness: 35 $\mu$ m  
 : represents a resist pattern.

Code	HCR32
a	2.2
b	5.0
c	2.0
f	(2.5)

##### 6-4-2. Board B (HCR32)

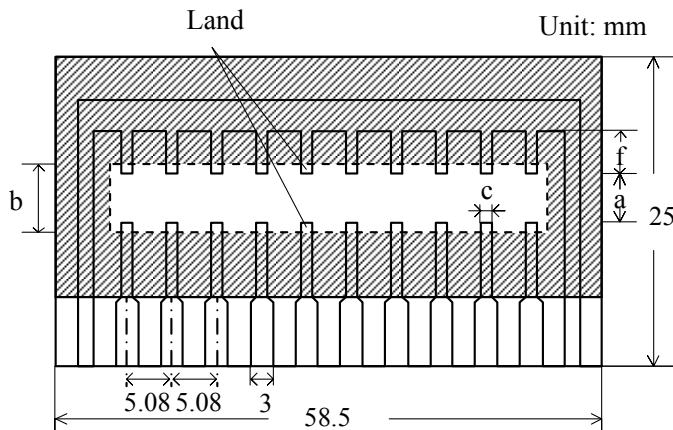

Material: Glass epoxy resin  
Board thickness: 1.6mm  
Copper foil thickness: 35  $\mu$ m  
 : represents a resist pattern.

Code	HCR32
a	2.2
b	5.0
c	2.0
f	(3.3)

\* The dimensions in ( ) in the table shall be used as a guide only, not as the standard.

Standard No.	Revision code	Designation of standard	Page
CR-D-8049		Product standard	11/19

## 7. Packing

### 7-1. Taping

#### 7-1-1. Paper taping HCR32

##### 7-1-1-1. Composition

The leader shall have empty angular holes  $250 \pm 50$ mm and a top cover tape portion  $250 \pm 50$ mm. The empty angular hole at the end shall be  $250 \pm 50$ mm.

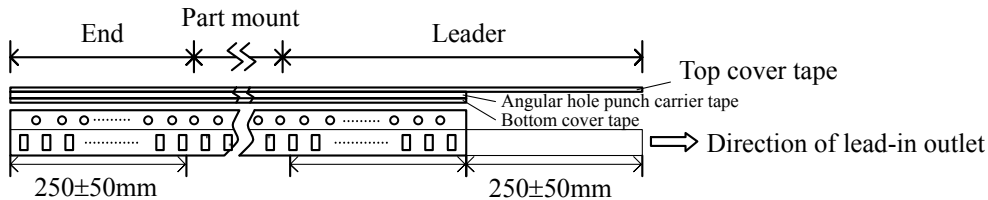

The chip resistor shall be able to move in the angular holes in the carrier tape. The taping shall be composed as shown in the diagram shown below.

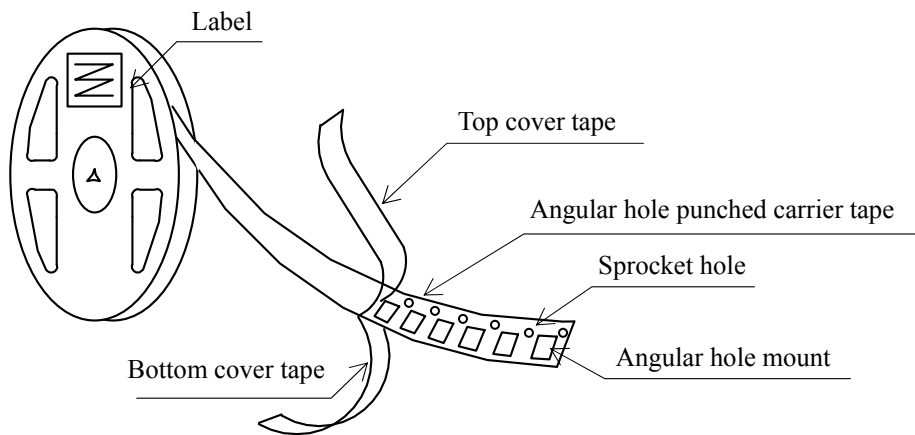

##### 7-1-1-2. Dimensions

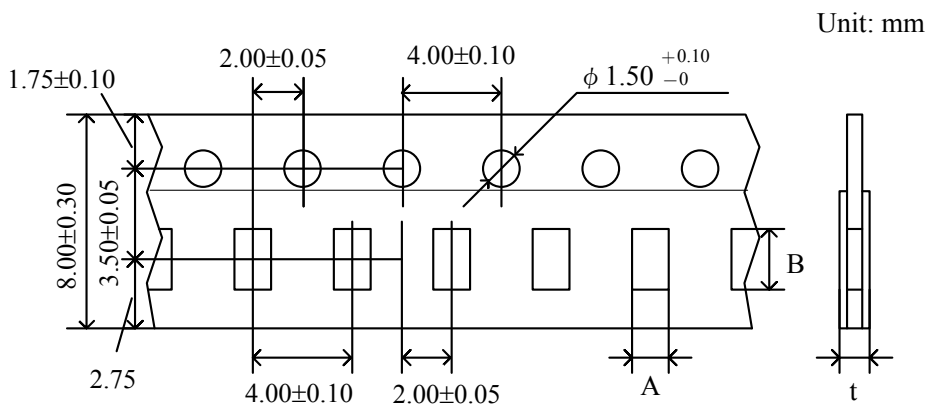

Code	HCR32
A	+0.10 2.00 -0.15
B	+0.10 3.57 -0.15
t	0.80±0.20

Standard No.	Revision code	Designation of standard	Page
CR-D-8049		Product standard	12/19

### 7-1-3. Performance

#### 7-1-3-1. Peel strength of top cover tape

The top cover tape shall have a peel strength of 0.1-0.7N {10.2-71.4gf} when it is pulled at 165-180° and at a speed of 300mm/min as shown in the diagram below.

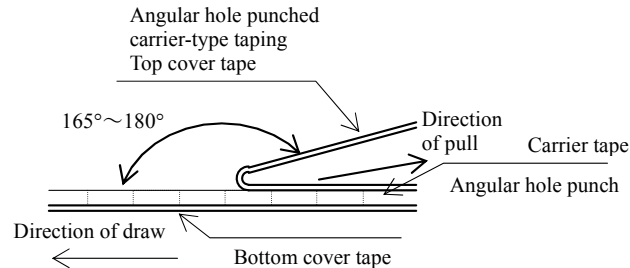

#### 7-1-3-2. Minimum bending radius

When the tape is bent to a radius of 30mm as shown in the diagram given below, the part shall be held on the tape and shall be free of damage and other anomalies.

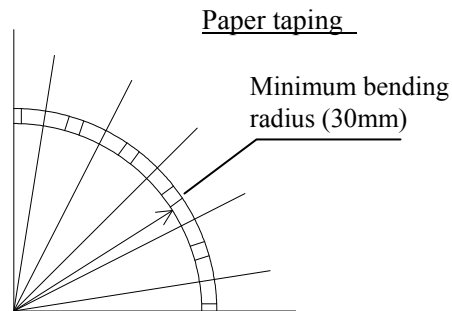

#### 7-1-3-3. Number of missing parts and taping errors

The number of missing parts shall not exceed 0.1% of the total number of parts (the indicated number) of reels, or one, whichever is the larger, and shall not exceed 2 consecutively.

The part shall be taped with its label facing upwards. It shall not be taped with the front and rear sides oriented wrongly.

#### 7-1-3-4. Storage performance

When a taped part is stored at temperatures between -5 and +40°C, relative humidities between 40 and 60%, without exposing it to direct sunlight, the tape shall not decline in sticking force or peel strength, shall not come off, and shall not decline in any other performance.

The part shall be stored for one year.

Standard No.	Revision code	Designation of standard	Page
CR-D-8049		Product standard	13/19

**7-1-4. Shape and dimensions of plastic reel (material : Polystyrene)**

Unit: mm

**7-1-4-1. Current type reel**

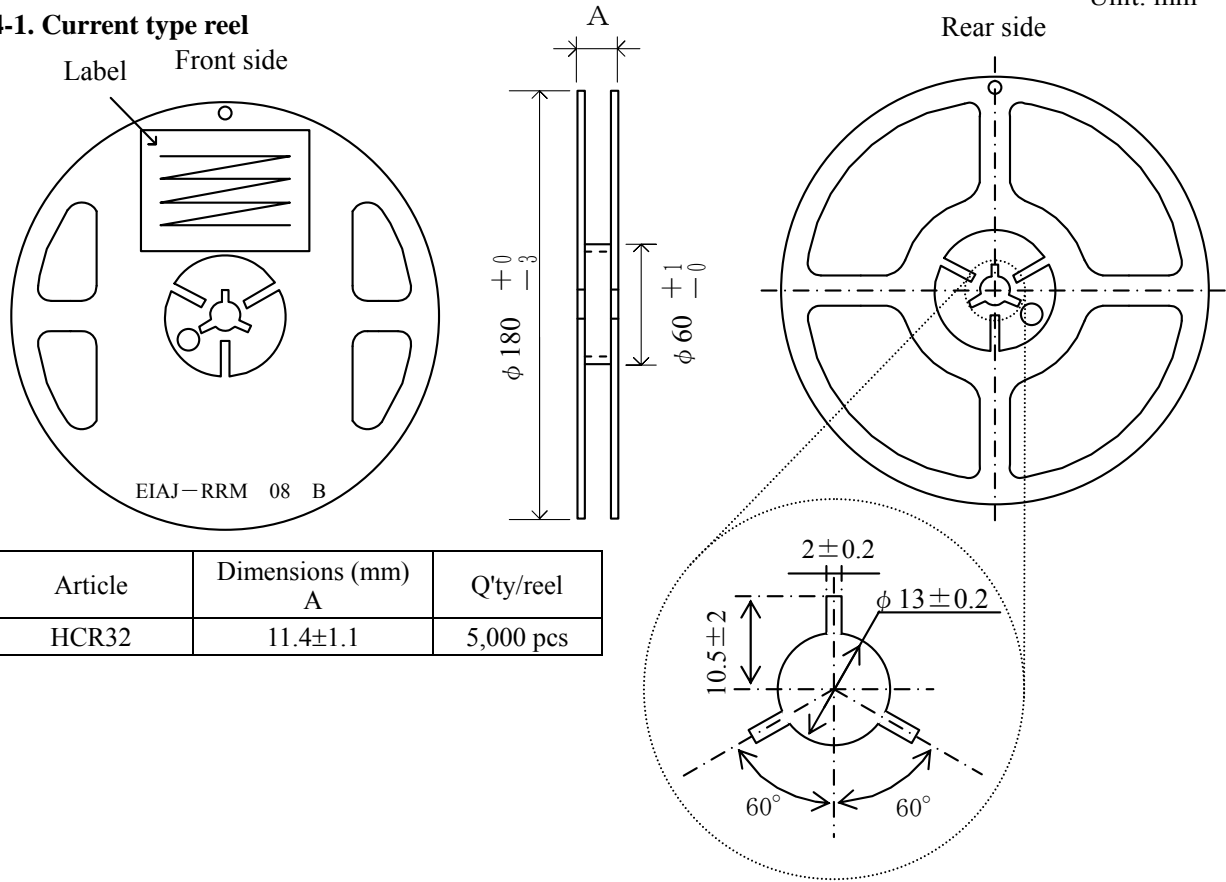

Article	Dimensions (mm) A	Q'ty/reel
HCR32	11.4±1.1	5,000 pcs

**7-1-4-2. New type reel**

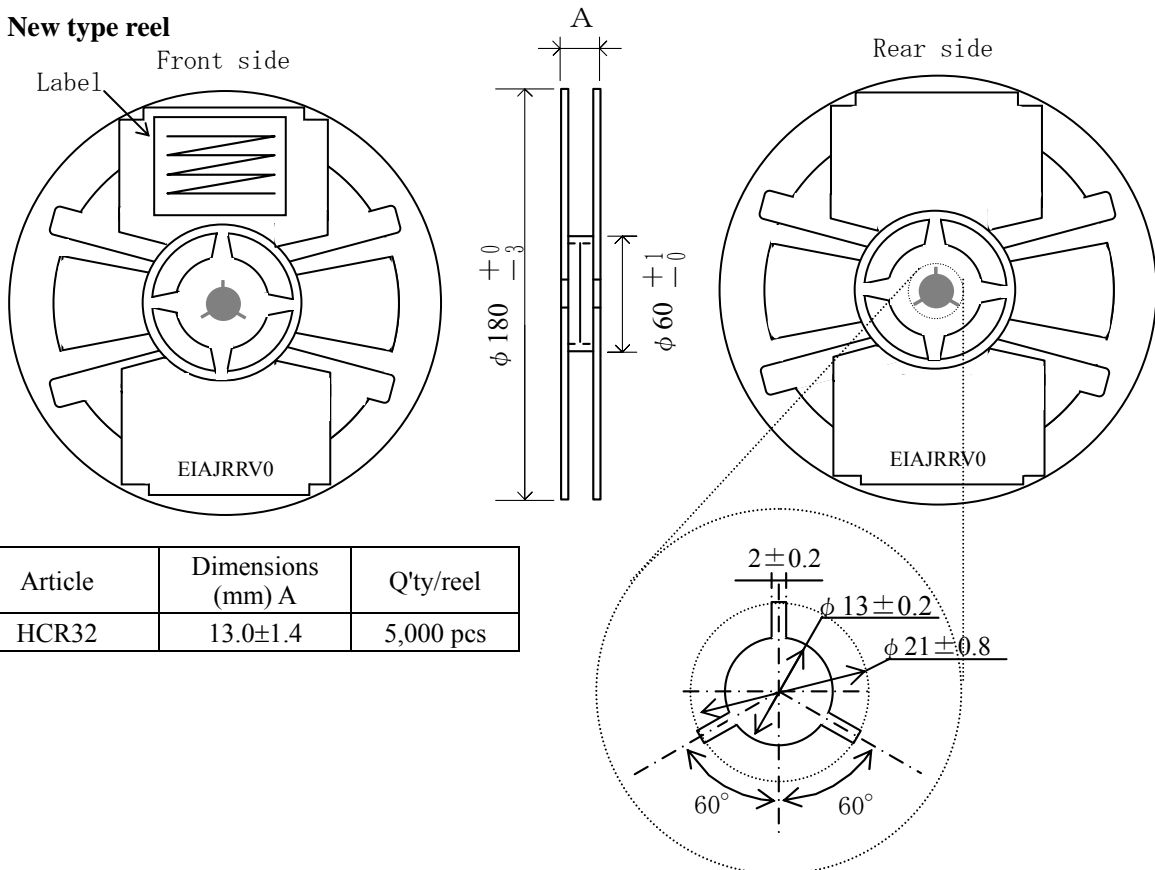

Article	Dimensions (mm) A	Q'ty/reel
HCR32	13.0±1.4	5,000 pcs

Standard No.	Revision code	Designation of standard	Page
CR-D-8049		Product standard	14/19

## 7-2. Bulk

### 7-2-1. Form of packing

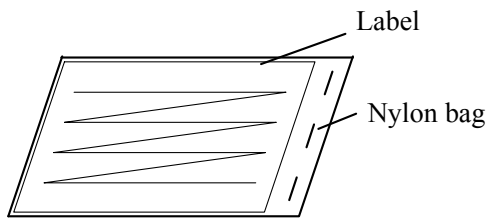

### 7-2-2. Labeling

- (1) Article
- (2) Nominal resistance
- (3) Resistance allowance
- (4) Quantity
- (5) Date Code
- (6) Lot No.
- (7) Name of manufacturer (method of indication: HOKURIKU)
- (8) Country of origin (method of indication: MADE IN JAPAN)
- (9) Indication of nonleadedness (method of indication: Pb(F))

Standard No.	Revision code	Designation of standard	Page
CR-D-8049		Product standard	15/19

## 8. Packing specifications

### 8-1. Inner case

#### 8-1-1. Inner case for taping

##### 8-1-1-1. Packing method

The reels shall be contained in inner cases as specified below.

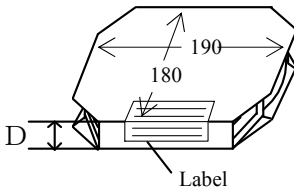
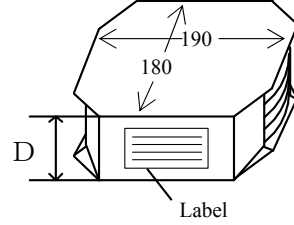
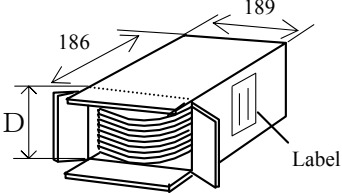
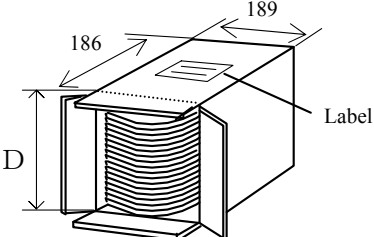
Number of reels	Dimension D (mm)	Inner case
1	15	
1	27	
2	38	
3	48	
5	60	
4	70	
7	122	
15	244	

##### 8-1-1-2. Markings on inner cases

All inner cases shall be marked with the following:

- (1) Article
- (2) Nominal resistance
- (3) Resistance allowance
- (4) Quantity
- (5) Date Code
- (6) Name of manufacturer (method of indication: HOKURIKU)
- (7) Country of origin (method of indication: MADE IN JAPAN)
- (8) Indication of nonleadedness (method of indication: Pb(F))

Standard No.	Revision code	Designation of standard	Page
CR-D-8049		Product standard	16/19

## 8-1-2. Inner case of bulk casing

### 8-1-2-1. Form of packing

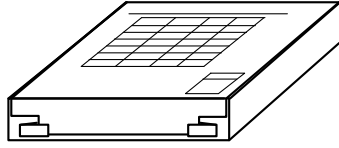

### 8-1-2-2. Markings

All inner cases shall be marked with the following:

- (1) User name
- (2) Article
- (3) Nominal resistance
- (4) Resistance allowance
- (5) Quantity
- (6) Name of manufacturer (method of indication: HOKURIKU)
- (7) Country of origin (method of indication: MADE IN JAPAN)
- (8) Indication of nonleadedness (method of indication: Pb(F))



Standard No.	Revision code	Designation of standard	Page
CR-D-8049		Product standard	17/19

## 8-2. Outer cases

Package size (mm)		
L	W	H
205	140	200
265	205	200
390	205	200
520	205	200
390	400	200
520	400	200
645	400	200

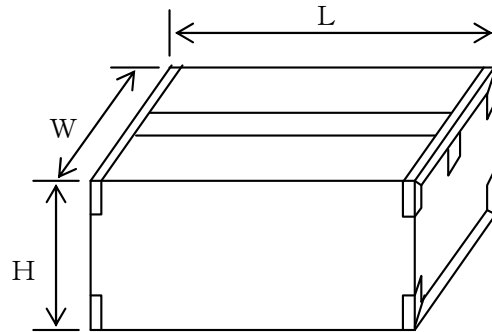

## 9. Operating instructions

### 9-1. Storage conditions

It is guaranteed that the product will retain normal solderability for one year in the standard state as per JIS C 5201-1, clause 4.2 (at temperatures between 15 and 35°C and relative humidities between 25 and 75%).

### 9-2. Environment

When in contact with a gaseous body of an ammonia, ion, or halogen compound, the solder plating on the electrodes will corrode, resulting in trouble with solderability or a wire break. The product shall therefore not be used under such conditions.

### 9-3. Work with a soldering iron (including solder corrections)

Solderability shall be ensured by applying the tip of the rod gently to the part to be soldered so that the chip will not float. The temperature of the rod tip shall not exceed 380°C, with a soldering time of no more than 3 seconds/operation. The soldering of the same electrode shall be finished with no more than three operations. If more than three operations are required, the part shall be replaced with a new one.

### 9-4. Flow solder

The solder shall be coated first with flux and then preheated (generally at 130-150°C for 1-3 minutes). The solder bath shall be no more than 260°C, with a soldering time of no more than 10 seconds. The soldering time for double waving shall be the sum of the two waves.

Standard No.	Revision code	Designation of standard	Page
CR-D-8049		Product standard	18/19

**9-5. Reflow solder**

**Reflow condition (Recommendation) : Sn—3.0Ag-0.5Cu**

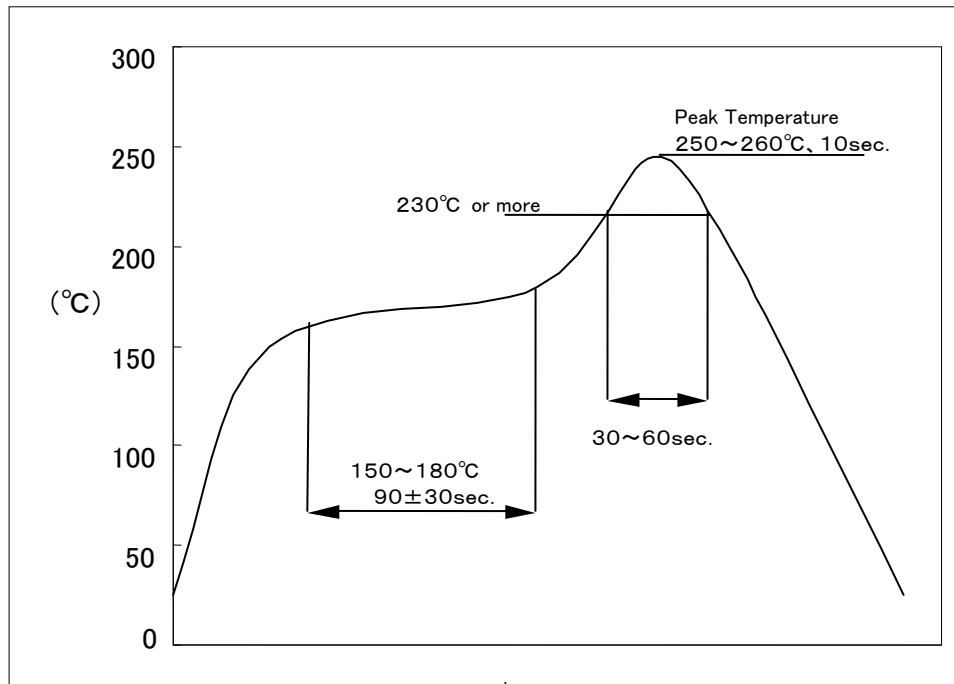

**9-6. Operating voltage**

The conditions specified in clause 4-1 shall be used. At that time, care shall be taken not to let the product heat itself. Particular care shall be taken of the HCR32 not to let them affect other parts, because they have large rates of heat-up.

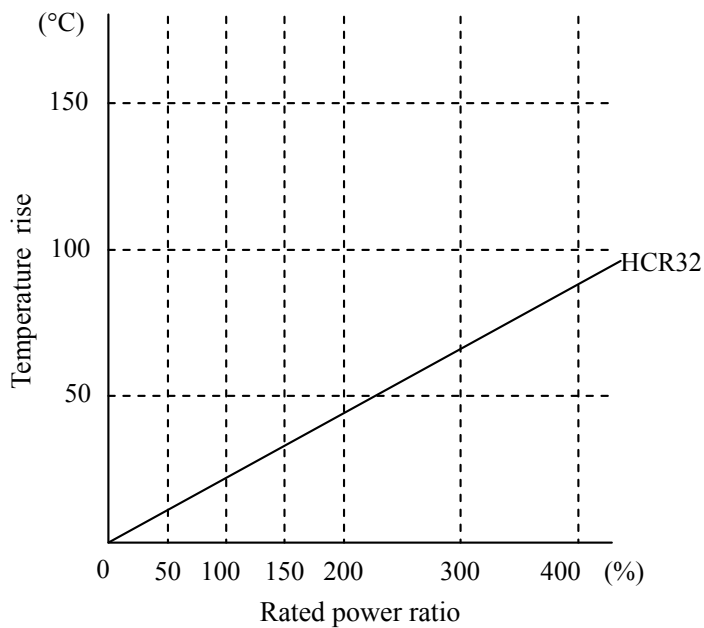

Standard No.	Revision code	Designation of standard	Page
CR-D-8049		Product standard	19/19

### 9-7. Recommended land pattern

The chart below shows the recommended land dimensions.

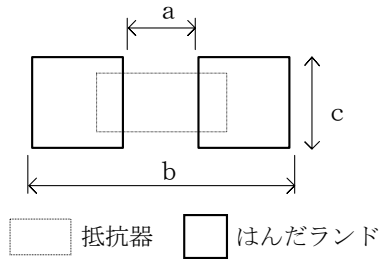

Article	Dimensions (mm)		
	a	b	c
HCR32	2.2	5.0	1.5

### 9-8. Layout

The products shall be so laid out as to minimize the impact that they may receive from the bend or deflection of the board when it is divided. The products shall not be installed in places close to the dividing line or prone to strains.

### 9-9. Low resistance

Low-resistance resistors shall be used with care because the resistance of the wiring may be a few percent of that of the resistor.

### 9-10. Coating

Resin burying, coating, and similar operations may change the resistance greatly depending on the material used. The material shall therefore be checked before use.

## 10. Industrial property rights

All disputes related to any industrial property right concerning the design or manufacture of any product or part delivered to the client as per this standard will be solved by the manufacturer upon its own responsibility.

## 11. Other

**11-1. No ozone-depleting substances are used.**

**11-2. No bromine-based substances are used.**

**11-3. These products do not apply to the Export Trade Control Ordinance table 1<sup>st</sup> to strategic and similar materials.**

**11-4. This standard guarantees the quality of the parts as handled singly. When in use, they shall be evaluated and checked as mounted on a product of the client.**

**11-5. The manufacturer will not take any responsibility for any trouble stemming from any action deviating from any of the descriptions of this standard.**

### 11-6. RoHS directive

**The toxic six substances restricted by the RoHS directive are not used.**

### 11-7. Country of origin

Japan

### 11-8. Production plant

Hokuriku Electric Industry Co., Ltd.

Affiliate: Asahi Denshi Co., Ltd.

358, Oienosyo, Asahi-machi, Shimo-niikawa-gun, Toyama-ken Prefecture 939-0722, Japan

TEL (0765) 82-1740 FAX (0765) 82-1739

## X-ON Electronics

Largest Supplier of Electrical and Electronic Components

*Click to view similar products for [Thick Film Resistors - SMD category](#):*

*Click to view products by [Hokuriku manufacturer](#):*

Other Similar products are found below :

[CR-05FL7--150R](#) [CR-05FL7--19K6](#) [CR-05FL7--243R](#) [CR-05FL7--40K2](#) [CR-05FL7--698K](#) [CR-12FP4--324R](#) [CR-12JP4--680R](#)

[M55342K06B1E78RS3](#) [M55342K06B6E19RWL](#) [M55342K06B6E81RS3](#) [M55342M05B200DRWB](#) [M55342M06B4K70MS3](#) [MC0603-511-](#)

[JTW](#) [742C083750JTR](#) [MCR01MZPF1202](#) [MCR01MZPF1601](#) [MCR01MZPF1800](#) [MCR01MZPF6201](#) [MCR01MZPF9102](#) [MCR01MZPJ113](#)

[MCR01MZPJ121](#) [MCR01MZPJ125](#) [MCR01MZPJ751](#) [MCR03EZHJ103](#) [MCR03EZPFX2004](#) [MCR03EZPJ270](#) [MCR03EZPJ821](#)

[MCR10EZPF1102](#) [MCR18EZPJ330](#) [RC0603F1473CS](#) [RC0603F150CS](#) [RC1005F1152CS](#) [RC1005F1182CS](#) [RC1005F1372CS](#)

[RC1005F183CS](#) [RC1005F1911CS](#) [RC1005F1912CS](#) [RC1005F203CS](#) [RC1005F2052CS](#) [RC1005F241CS](#) [RC1005F2431CS](#)

[RC1005F3011CS](#) [RC1005F303CS](#) [RC1005F4321CS](#) [RC1005F4642CS](#) [RC1005F471CS](#) [RC1005F4751CS](#) [RC1005F5621CS](#)

[RC1005F6041CS](#) [RC1005J106CS](#)