

S P E C I F I C A T I O N

Product Name VARIABLE RESISTOR

Model No. VG039NCHXT

Control No. 412

Date January 9, 2007

HOKURIKU ELECTRIC INDUSTRY CO., LTD.
COMPONENTS DIVISION
ELECTRO-MECHANICAL COMPONENT FACTORY

SALES DEPARTMENT
Sales Representative
Approved

ELECTRO-MECHANICAL COMPONENT FACTORY	
Drawn	<i>N.Kurata</i>
Checked	<i>M.Kanagawa</i>
Checked	<i>H.Takabayashi</i>
Approved	<i>T.Nakayama</i>

The contents of this specification may change without prior notice. For inquiries, please refer to product name, model No., and control No. written in the cover sheet of this specification. Because this specification is for reference only, for your actual use of this part please acknowledge and sign the formal specification for this part.

1. Scope

This specification applies to 3 mm Chip trimmer potentiometer with Metal - Glaze - Resistor, used in electronic equipment.

2. Construction (Dimensions and Materials) and Rating

- 2.1. Dimension See attached Drawing.
- 2.2. Materials See attached Material List
- 2.3. Operating Temperature Range -40 ~ +100
- 2.4. Storage Temperature Range -10 ~ +40
- 2.5. Nominal Total Resistance Range 100 ~ 1 M
(1 · 2 · 3 · 5 series, see attached Application List)
- 2.6. Total Resistance Tolerance ± 25 %
- 2.7. Power Rating 0.15 W (~ +70)
Power rating vs. ambient temperature shall be denoted on the following chart.

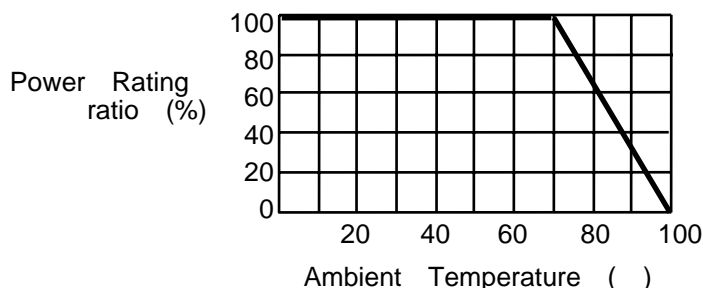

- 2.8. Rated Voltage Rated Voltage $E = \sqrt{P \cdot R}$
Where P : Power Rating (W)
R : Nominal Total Resistance ()
When the rated voltage exceeds the maximum operating voltage, the maximum operating voltage shall be the rated voltage.
- 2.9. Maximum Operating Voltage 50 V

Review Item 2.4, 3.3.2		2006.11.11 H.Takabayashi			
Add Item 5.4 and review Item 5.		2006.8.2 H.Takabayashi			
DRAWN N.Kurata DATE Oct./11/'06	CHECKED H.Takabayashi DATE Oct./11/'06	APPROVALS M.Urayama DATE Oct./11/'06	TITLE VARIABLE RESISTOR	HDK TYPE VG039NCH	REV. B
DATE Oct., 11, 2006		HOKURIKU ELECTRIC INDUSTRY CO.,LTD.		HDK. DWG. NO. W-6522	1 / 7

3. Characteristics

Standard atmospheric conditions

Unless otherwise specified, the standard range of atmospheric conditions for making measurements and tests is as follows :

Ambient temperature : 5 to 35
 Relative humidity : 45 % to 85 %
 Air pressure : 860 hPa to 1 060 hPa

If there is any doubt about the results, measurements shall be made within the following limits :

Ambient temperature : 20 ± 2
 Relative humidity : 60 % to 70 %
 Air pressure : 860 hPa to 1 060 hPa

3.1. Mechanical characteristics

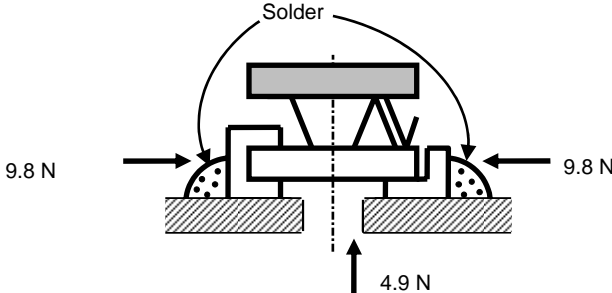
	Item	Conditions	Specifications
1	Total Mechanical Rotation		270 ° ± 20 °
2	Rotational Torque		0.98 mN·m ~ 11.76 mN·m
3	End Stop Strength	The following torsion moment of 14.7 mN·m shall be applied to the spindle for 5 seconds in any direction.	Without distinct looseness or poor contact.
4	Soldering Strength	A static load shown in this figure shall be applied to terminals for 30 s after soldering. 	Without distinct looseness or poor contact.
5	Push Load	A push load of 9.8 N shall be applied to the axial direction for 30 seconds from upper part of the product.	Without distinct looseness or poor contact. Without board breaking.

DRAWN N.Kurata DATE Oct./11/06		CHECKED H.Takabayashi DATE Oct./11/06		APPROVALS M.Urayama DATE Oct./11/06		TITLE VARIABLE RESISTOR		HDK TYPE VG039NCH		REV. B	
DATE Oct. ,11, 2006		HOKURIKU ELECTRIC INDUSTRY CO.,LTD.						HDK. DWG. NO. W-6522		2 / 7	

3. Characteristics

3.2. Electrical characteristics

	Item	Conditions		Specifications										
1	Resistance Law (Taper)	Output voltage ratio at the middle of total rotational angle.		40 % ~ 60 % (Linear taper)										
2	Ineffective Rotation	Ineffective rotation is the sum of all rotational distances in which resistance does not change and is calculated as a percentage of the total mechanical rotation.		10 % or less of total mechanical rotation, at each end.										
3	Residual Resistance	The resistances at each end of the mechanical rotation between terminals 1 and 2, or 2 and 3 shall be measured.	Total nominal resistance 1 k or less	20 or less										
			Total nominal resistance more than 1 k	2 % or less of total nominal resistance.										
4	Contact Resistance	<p>The moving contact shall be rotated to a point where the resistance between terminals 1 and 2 is half of the total resistance. Contact resistance shall be calculated by the following formula :</p> $\frac{(R_{12}+R_{23}) - R_{13}}{2 \times R_{13}} \times 100(\%)$ <p>Where R₁₂ : Resistance between terminals 1 and 2 R₂₃ : Resistance between terminals 2 and 3 R₁₃ : Resistance between terminals 1 and 3</p>		5 % or less of nominal total resistance.										
5	Temperature Coefficient (T. C. R.)	<p>The trimmer potentiometer shall be maintained in a thermostatic chamber at a temperature, according to the table as shown below.</p> <table border="1" style="margin-left: auto; margin-right: auto;"> <thead> <tr> <th>Step</th> <th>Temperature()</th> </tr> </thead> <tbody> <tr> <td>Initial</td> <td>+25 ± 2</td> </tr> <tr> <td>1</td> <td>-40 ± 3</td> </tr> <tr> <td>2</td> <td>+25 ± 2</td> </tr> <tr> <td>3</td> <td>+100 ± 3</td> </tr> </tbody> </table> <p>The measurement shall be made, after the thermostatic chamber achieved the mark temperature and maintained for 30 min ~ 45min.</p>		Step	Temperature()	Initial	+25 ± 2	1	-40 ± 3	2	+25 ± 2	3	+100 ± 3	Within ± 250 ppm/
Step	Temperature()													
Initial	+25 ± 2													
1	-40 ± 3													
2	+25 ± 2													
3	+100 ± 3													

DRAWN N.Kurata DATE Oct./11/'06		CHECKED H.Takabayashi DATE Oct./11/'06	APPROVALS M.Urayama DATE Oct./11/'06	TITLE VARIABLE RESISTOR	HDK TYPE VG039NCH	REV. B
DATE Oct. ,11, 2006		HOKURIKU ELECTRIC INDUSTRY CO.,LTD.			HDK. DWG. NO. W-6522	3 / 7

3.3. Endurance characteristics

When the items in mark, the moving contact shall be rotated to a point where the resistance between 1 and 2 is half of the total resistance.

	Item	Conditions	Specifications															
1	Vibration	The entire frequency range, from 10 Hz to 55 Hz and return to 10 Hz, shall be transversed in 1 min. Amplitude (total excursion): 1.5 mm This motion shall be applied for a period of 2 h in each of 3 mutually perpendicular directions. (a total of 6 h)	Change in resistance between 1 and 2 is relative to the value before test. Within $\pm 5\%$ Without an instant open during the test.															
2	Resistance to Soldering Heat	<u>Re-flow soldering method</u> Peak temperature : Within 260 10 s Application time : more than 230 , Within 40 s <u>Soldering iron method</u> Tip temperature : 400 ± 10 Application time of soldering iron : 3 s + 1 s / - 0 s.	Within $\pm 2\%$ of initial resistance.															
3	High Temperature Storage	The trimmer potentiometer shall be subjected in a thermostatic chamber at a temperature of 70 ± 2 without electrical load for 1 000 h ± 12 h. Then the trimmer potentiometer shall be taken out from the chamber and maintained at standard atmospheric conditions for 1 h ~ 2 h, after which measurements shall be made.	Change in total resistance is relative to the value before test. Within $\pm 5\%$															
4	Load Life	The trimmer potentiometer shall be subjected in a thermostatic chamber at a temperature of 70 ± 2 with a DC rated voltage for 1.5 h between terminals 1 and 3 followed by a pause of 30 min for 1 000 h ± 12 h. Then the trimmer potentiometer shall be taken out from the chamber and maintained at standard atmospheric conditions for 1 h ~ 2 h without electrical load, after which measurements shall be made.	Change in total resistance is relative to the value before test. Within $\pm 5\%$															
5	Temperature Cycle	The trimmer potentiometer shall be subjected in a thermostatic chamber at 5 successive change of temperature cycles, each as shown in table below. Then the trimmer potentiometer shall be taken out from the chamber and maintained at standard atmospheric conditions for 1 h ~ 2 h, after which measurements shall be made.	Change in total resistance is relative to the value before test. Within $\pm 2\%$ Without distinct looseness or poor contact.															
<table border="1"> <thead> <tr> <th data-bbox="448 1581 539 1630">Step</th> <th data-bbox="539 1581 967 1630">Temperature</th> <th data-bbox="967 1581 1141 1630">Duration</th> </tr> </thead> <tbody> <tr> <td data-bbox="448 1630 539 1671">1</td> <td data-bbox="539 1630 967 1671">- 40 ± 3</td> <td data-bbox="967 1630 1141 1671">30 min</td> </tr> <tr> <td data-bbox="448 1671 539 1738">2</td> <td data-bbox="539 1671 967 1738">Standard atmospheric conditions</td> <td data-bbox="967 1671 1141 1738">10 min to 15 min</td> </tr> <tr> <td data-bbox="448 1738 539 1778">3</td> <td data-bbox="539 1738 967 1778">100 ± 2</td> <td data-bbox="967 1738 1141 1778">30 min</td> </tr> <tr> <td data-bbox="448 1778 539 1854">4</td> <td data-bbox="539 1778 967 1854">Standard atmospheric conditions</td> <td data-bbox="967 1778 1141 1854">10 min to 15 min</td> </tr> </tbody> </table>		Step	Temperature	Duration	1	- 40 ± 3	30 min	2	Standard atmospheric conditions	10 min to 15 min	3	100 ± 2	30 min	4	Standard atmospheric conditions	10 min to 15 min		
Step	Temperature	Duration																
1	- 40 ± 3	30 min																
2	Standard atmospheric conditions	10 min to 15 min																
3	100 ± 2	30 min																
4	Standard atmospheric conditions	10 min to 15 min																

DRAWN N.Kurata DATE Oct./11/06	CHECKED H.Takabayashi DATE Oct./11/06	APPROVALS M.Urayama DATE Oct./11/06	TITLE VARIABLE RESISTOR	HDK TYPE VG039NCH	REV. B
DATE Oct. ,11, 2006		HOKURIKU ELECTRIC INDUSTRY CO.,LTD.		HDK. DWG. NO. W-6522	4 / 7

	Item	Conditions	Specifications
6	Humidity	The trimmer potentiometer shall be subjected in a thermostatic chamber at a temperature of 40 ± 2 with relative humidity of 90% to 95% without electrical load for $1\,000\text{ h} \pm 12\text{ h}$. Then the trimmer potentiometer shall be taken out from the chamber and its surface moisture shall be removed. And then the trimmer potentiometer shall be maintained at standard atmospheric conditions for $1\text{ h} \sim 2\text{ h}$, after which measurement shall be made.	Change in total resistance is relative to the value before test. Within $\pm 5\%$
7	Humidity Load Life	The trimmer potentiometer shall be subjected in a thermostatic chamber at a temperature of 40 ± 2 and a relative humidity of 90% to 95% with a DC rated voltage for 1.5 hours between terminals 1 and 3 followed by a pause of 30 minutes for $1\,000\text{ h} \pm 12\text{ h}$. Then the trimmer potentiometer shall be taken out from the chamber and its surface moisture shall be removed. And then the trimmer potentiometer shall be maintained at standard atmospheric conditions for $1\text{ h} \sim 2\text{ h}$ without electrical load, after which measurement shall be made.	Change in total resistance is relative to the value before test. Within $\pm 5\%$
8	Rotational Life	The moving contact shall be rotated without electrical load for $20\text{ cycles} \pm 2\text{ cycles}$ at a rate of 10 min^{-1} . (A cycle of operation is defined as the travel of the moving contact from one end of the resistance element to the other and back through 90% of the total mechanical rotation.)	Change in total resistance is relative to the value before test. Within $\pm 10\%$

4. Marking

Nominal total resistance First number shows significant figures and the other shows quantity of zero.

ex. 1 k 13
 10 k 14
 100 k 15

Significant figures Quantity of zero

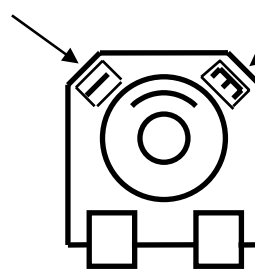

13 (1 k)

DRAWN N.Kurata DATE Oct./11/'06		CHECKED H.Takabayashi DATE Oct./11/'06	APPROVALS M.Urayama DATE Oct./11/'06	TITLE VARIABLE RESISTOR	HDK TYPE VG039NCH	REV. B
Oct. ,11, 2006		HOKURIKU ELECTRIC INDUSTRY CO.,LTD.			W-6522	5 / 7

5. The others

5.1. Preset Position

The moving contact set half position of total rotation angle (50 % ± 15 % of total rotation angle) on delivery.

5.2. Application Notes

- The soldering for this product should be reflow soldering. Please note that this product is not applicable to flow soldering.
- Be careful with flying flux in soldering.
- If flux was stuck on the resistance, please wash it out thoroughly by alcoholic solvent.
- Handle the trimmer potentiometer with care.
- This product is not what meant the use to affect the human body life which needs advanced safety and reliability, and the use of nuclear relation, and carried out design manufacture.
- Please refer to EIAJ RCR-2191A "notes guideline(safe application guide of a potentiometer) of the potentiometer for electric devices" about notes on other use.
- In a case where there is a wiring pattern right under this product after mounting. Please be sure to do some insulation measures on the pattern with a resist or some other materials.

5.3. The wish matter of the consideration to the safety of a product

Although we are exerting our best effects to maintain the quality of this product, we cannot guarantee that they will never cause short circuiting and open circuitry.

Therefore, when designing an equipment or device with which the priority is given to the safety, you will please carefully study the influences to the whole equipment of a single function failure of potentiometer in advance to make out a fail-safe design providing.

5.4. Industrial Proprietorship

If the trouble on industrial proprietorship (related on delivered product s design and production) happens, we solves it on own responsibility.

5.5. Nation of products

CHINA

DRAWN N.Kurata DATE Oct./11/'06		CHECKED H.Takabayashi DATE Oct./11/'06	APPROVALS M.Urayama DATE Oct./11/'06	TITLE VARIABLE RESISTOR	HDK TYPE VG039NCH	REV. B
DATE Oct. ,11, 2006		HOKURIKU ELECTRIC INDUSTRY CO.,LTD.			HDK. DWG. NO. W-6522	6 / 7

6. Taping Specification

- 6.1. Dimension..... Dwg. No.F-362.022
- 6.2. Taping direction Dwg. No.F-362.022 and Fig.2
- 6.3. Peeling strength of cover tape..... 0.1 N ~ 0.7 N
- 6.4. Taping method..... Fig.1
- 6.5. Taping quantity 2 500 pcs./reel

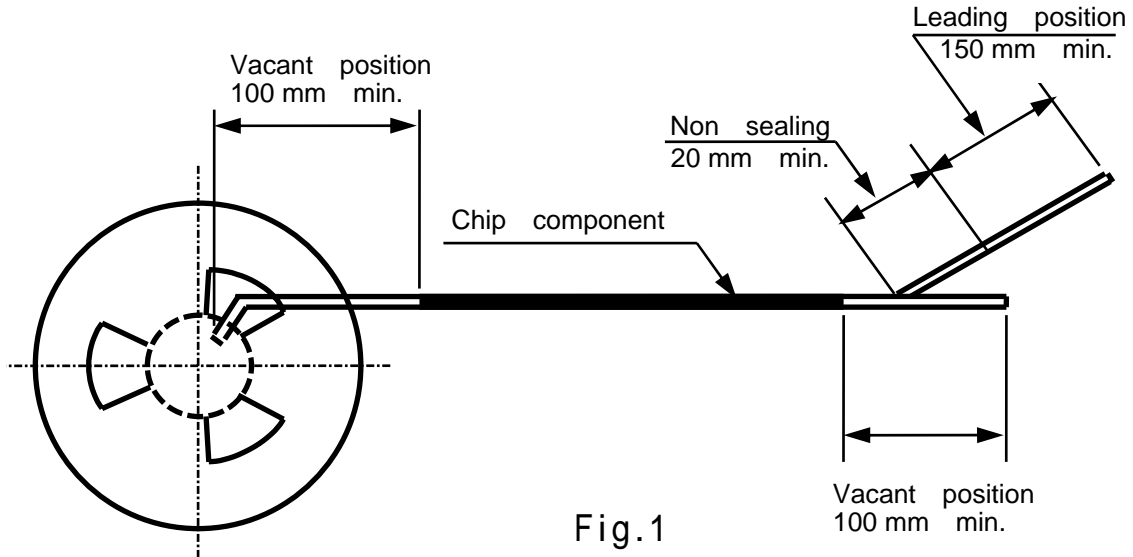

Fig.1

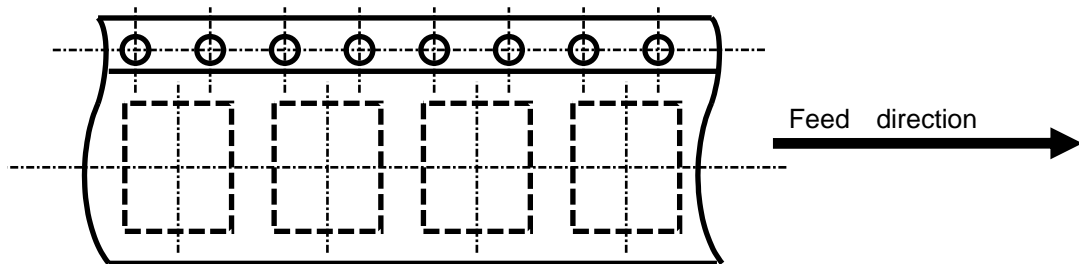
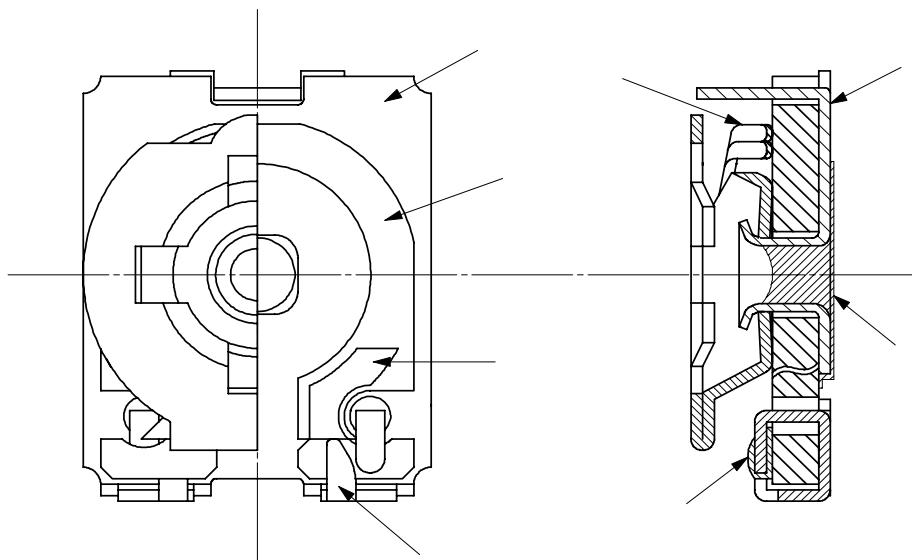

Fig2

DRAWN N.Kurata DATE Oct./11/06		CHECKED H.Takabayashi DATE Oct./11/06	APPROVALS M.Urayama DATE Oct./11/06	TITLE VARIABLE RESISTOR	HDK TYPE VG039NCH	REV. B
DATE Oct.,11, 2006		HOKURIKU ELECTRIC INDUSTRY CO.,LTD.			HDK. DWG. NO. W-6522	7/7



No.	PART NAME 部品名	BASE MATERIAL 材質	PLATING 処理
1	BOARD 基板	CERAMIC Al ₂ O ₃ セラミック (アルミナ)	
2	RESISTOR 抵抗体	METAL GLAZE COATING メタルグレーズ皮膜	
3	ELECTRODE 電極	AgPd 銀パラジウム	
4	1st, 3rd TERMINAL 1番, 3番 端子	STEEL 鋼板	UNDER PLATING Ni : 0.5 ~ 2 μm 下地メッキ
			SURFACE PLATING Sn : 2 μm ~ 4 μm 表面メッキ
5	2nd TERMINAL 2番 端子	STEEL 鋼板	UNDER PLATING Ni : 0.5 ~ 2 μm 下地メッキ
			SURFACE PLATING Sn : 2 μm ~ 4 μm 表面メッキ
6	TERMINAL JOINT 端子接合部	SOLDER (Sn-3Ag-0.5Cu) 鉛フリー半田	
7	MOVING CONTACT 摺動子	STAINLESS STEEL ステンレス	
8	SEALING RESIN 封止樹脂	ACRYL アクリル系	

	2007.1.9	下地メッキ厚変更 Correction Under Plating Thickness		高林		
	2006.12.21	No.8 部品名変更 Correction Part Name No.8		高林		
	訂正日/Date	訂正理由 / Reason of Correction		訂正者/Corrector	記事 / Account	
承認/Approved	検図/Checked	設計/Designed	写図/Drawn	文書名 / Title		種別 / HDK TYPE
浦山 M. Urayama		高林 H. Takabayashi		使用材料表 / Material List		VG039NCH
						版/Rev. B
作成日 / Original Date		北陸電気工業 株式会社			仕様書番号 / DWG.NO.	SHEET
2006/8/26		HOKURIKU ELECTRIC INDUSTRY CO., LTD.			W-6502	1/1

適用品一覽表 / Application List

(適用外形寸法図/Drawing : F-362.021,F-362.022)

Rev.	公称全抵抗値 Nominal Total Resistance	抵抗値 許容差 Tolerance	残留抵抗値/Residual Resistance		品番 Part Number	備考 Remark
			1-2 間 Between Terminal #1& #2	2-3 間 Between Terminal #2& #3		
	B100	± 25 %	20 max	20 max		VG039NCHXT B101
	B200					B201
	B220					B221
	B300					B301
	B330					B331
	B470					B471
	B500					B501
	B680					B681
	B1 k		↓	↓		B102
	B2 k		40 max	40 max		B202
	B2.2 k		44 max	44 max		B222
	B3 k		60 max	60 max		B302
	B3.3 k		66 max	66 max		B332
	B4.7 k		94 max	94 max		B472
	B5 k		100 max	100 max		B502
	B6.8 k		136 max	136 max		B682
	B10 k		200 max	200 max		B103
	B20 k		400 max	400 max		B203
	B22 k		440 max	440 max		B223
	B30 k		600 max	600 max		B303
	B33 k		660 max	660 max		B333
	B47 k		940 max	940 max		B473
	B50 k		1 k max	1 k max		B503
	B68 k		1.36 k max	1.36 k max		B683
	B100 k		2 k max	2 k max		B104
	B200 k		4 k max	4 k max		B204
	B220 k		4.4 k max	4.4 k max		B224
	B300 k		6 k max	6 k max		B304
	B330 k		6.6 k max	6.6 k max		B334
	B470 k		9.4 k max	9.4 k max		B474
	B500 k		10 k max	10 k max		B504
	B680 k		13.6 k max	13.6 k max		B684
	B1 M	↓	20 k max	20 k max		↓ B105

承認/Approved	検図/Checked	設計/Designed	写図/Drawn	文書名 / Title	種別 / HDK TYPE	版/Rev.
浦山 M. Urayama	/	高林 H. Takabayashi	/	製品規格 / Variable resistor	VG039NCHXT	
作成日 / Original Date	北陸電気工業 株式会社			仕様書番号 / DWG.NO.	SHEET	
2006/8/28	HOKURIKU ELECTRIC INDUSTRY CO., LTD.			W-6500	1/1	

4 3 2 1

摺動子回転範囲
Wiper Rotating Area

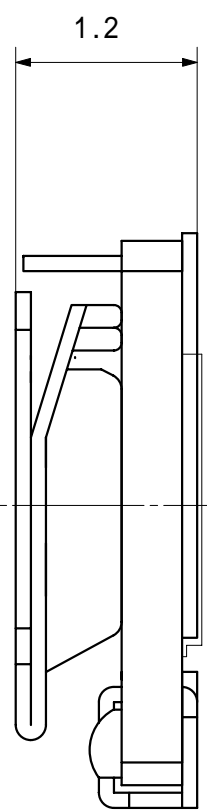
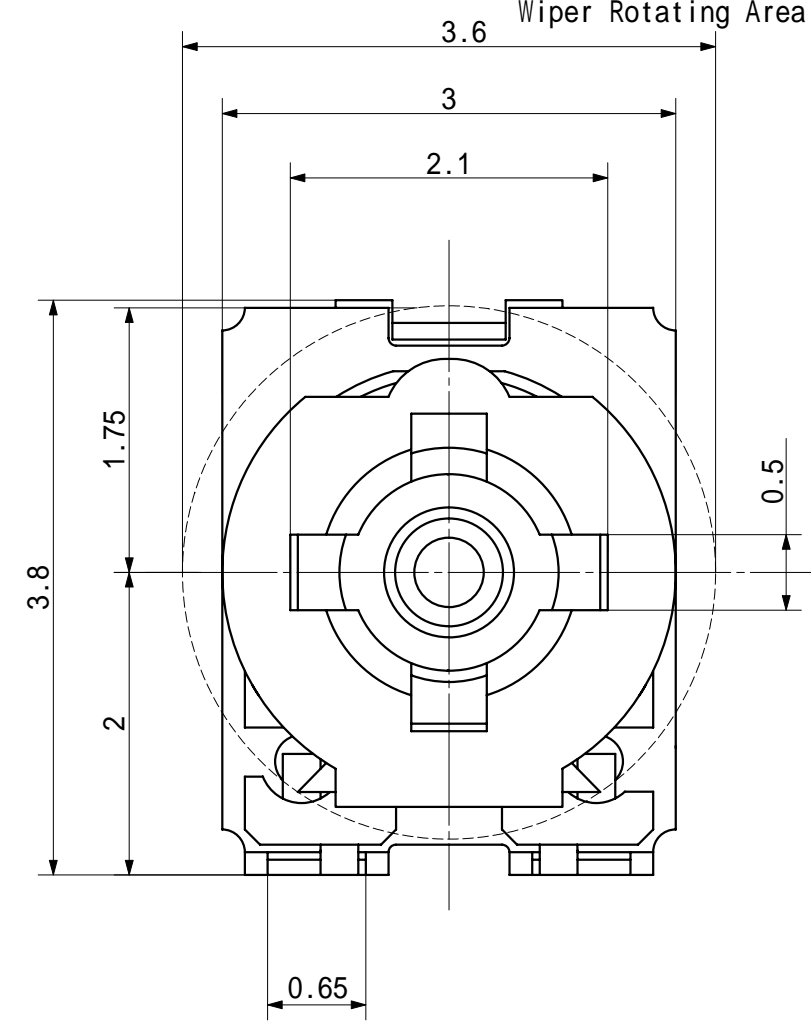

裏面樹脂封止
Resin

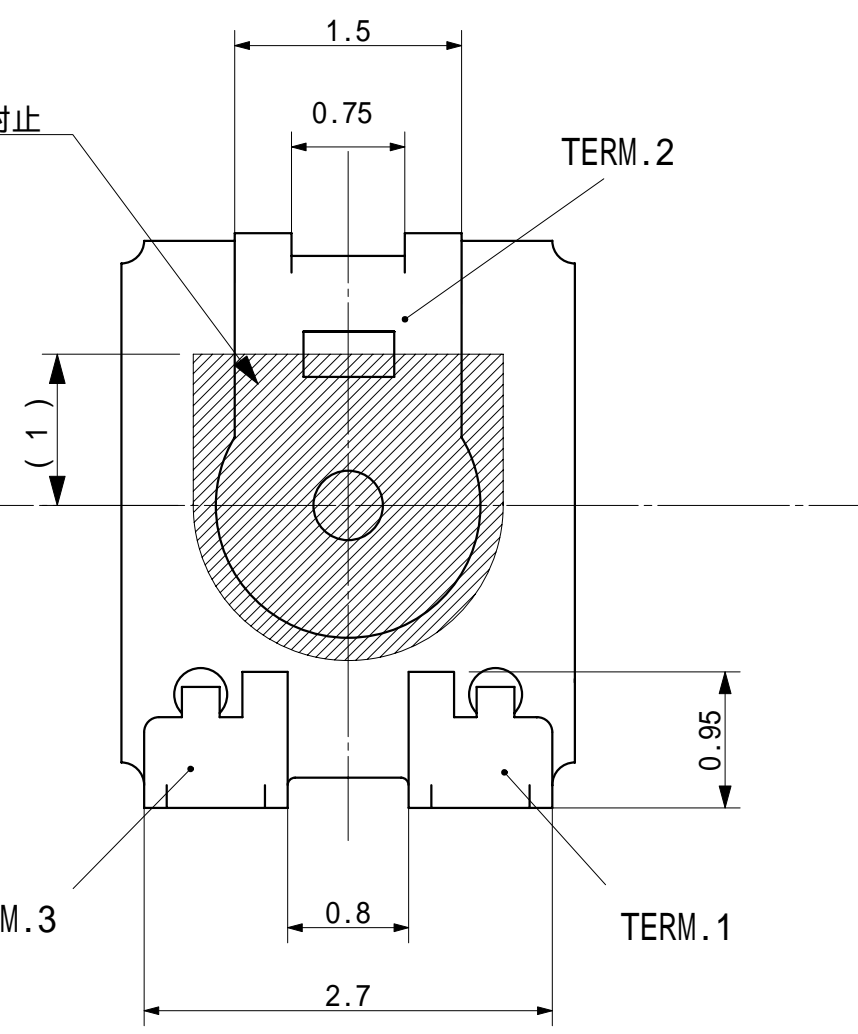

推奨ランドパターン寸法 (10/1)
PATTERN APPLICATION EXAMPLE (Scale 10/1)

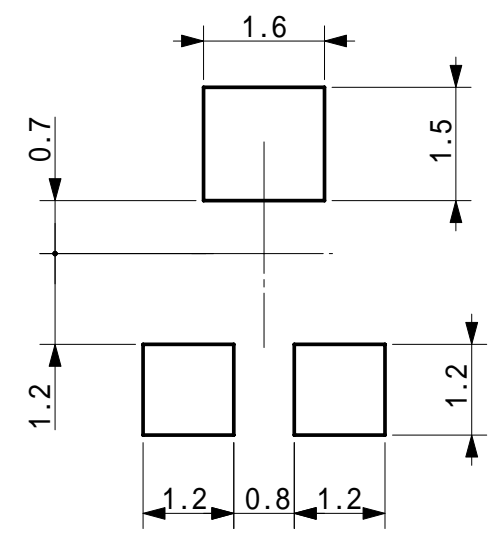

回路図
CIRCUIT

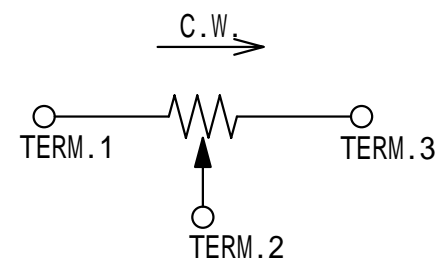

訂正箇所 REVISION PLACE		訂正年月日 REVISION DATE		訂正理由 REASON		訂正者 REVISION BY		記事/REMARK	
図法/DRAWING 第三角法 TRIGONOMETRY		単位/UNIT mm	尺度/SCALE 20/1	材料/MATERIAL		処理/DISPOSAL			種別・型名/MODEL NAME VG039NCH
承認/APPROVED BY M.Urayama Aug.-28-'06		検図/CHECKED BY		設計/DESIGNED BY H.Takabayashi Aug.-28-'06		写図/TRACED BY		図名/DESCRIPTION 外觀図 Drawing	
一般公差 GENERAL TOLERANCE ± 0.3 mm		作成年月日 DRAWING DATE Aug./28/'06		北陸電気工業株式会社 HOKURIKU ELECTRIC INDUSTRY CO.,LTD.				半固定可変抵抗器 Variable Resistor	版/REV. F-362.021

4 3 2 1

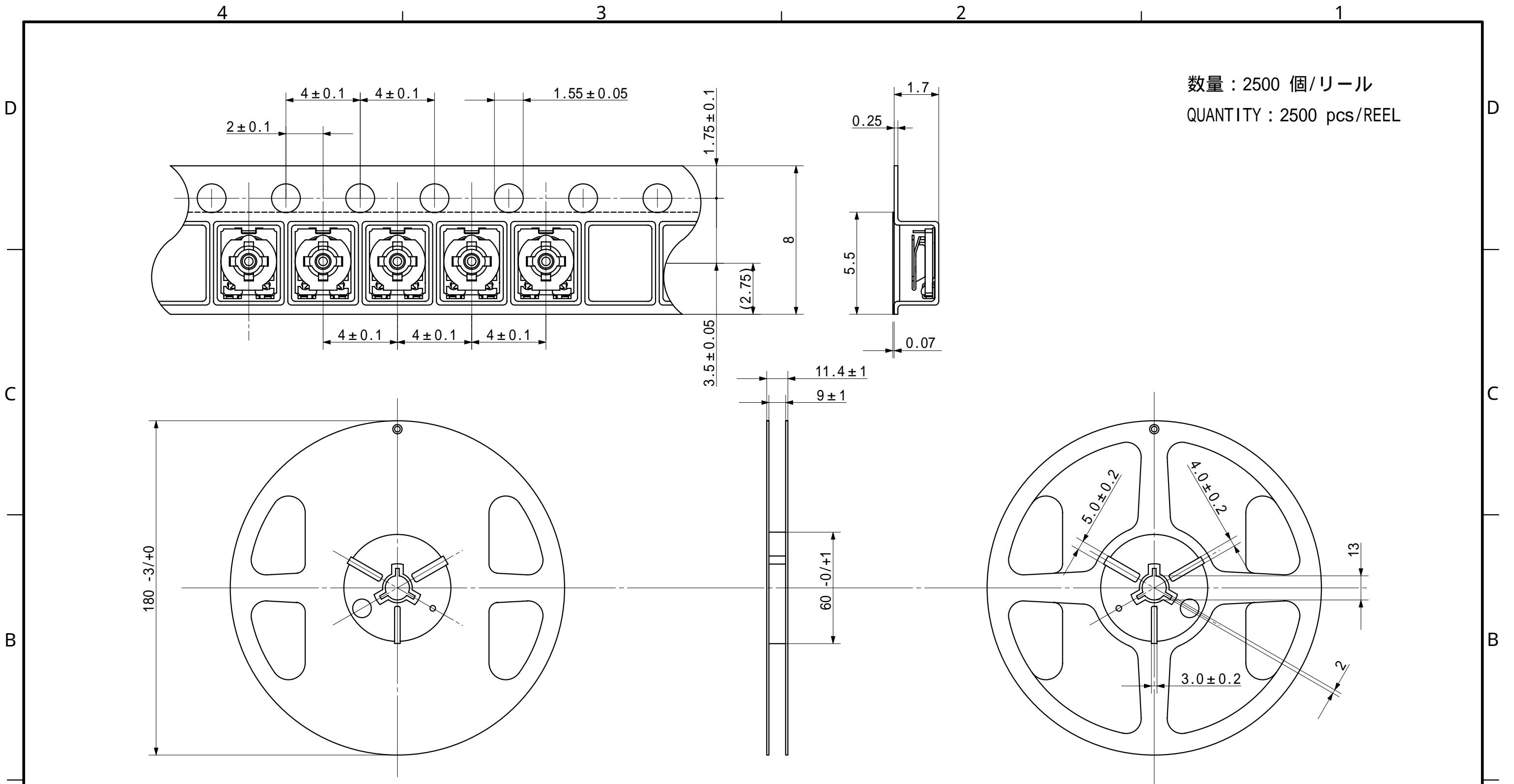

数量 : 2500 個/リール
 QUANTITY : 2500 pcs/REEL

尺度 SCALE 1/2

訂正 REVISIONS				
承認 APPROVED 浦山 M.Urayama DATE Aug.-28-'06	検図 CHECKED	設計 DESIGNED 高林 H.Takabayashi DATE Aug.-28-'06	単位 : UNIT 尺度 SCALE mm 5 / 1	タイトル TITLE テーピングリール TAPING REEL
種別/HDK TYPE VG039NCHXT	HDK 図面番号 DWG No. F-362.022		版 REV.	
北陸電気工業株式会社 HOKURIKU ELECTRIC INDUSTRY CO., LTD.			版 REV.	
一般公差 GENERAL TOLERANCE ± 0.3				

4 3 2 1

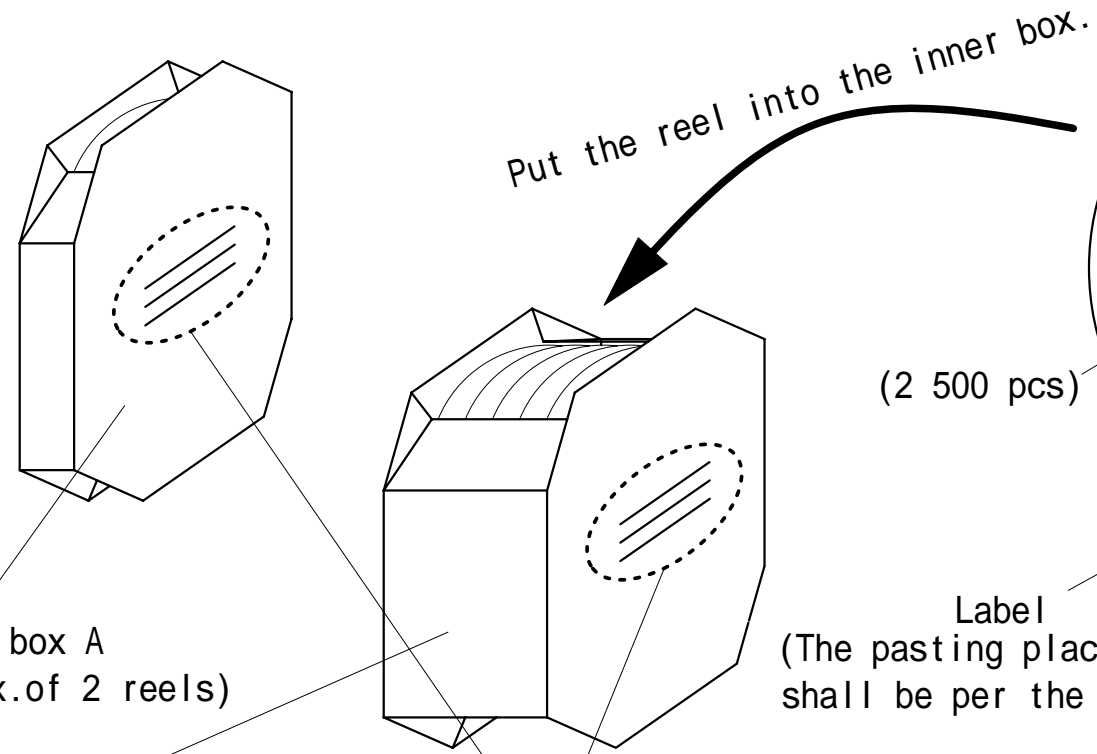

Inner box A
(A max. of 2 reels)

Inner box B
(A max. of 6 reels)

Label
(The pasting place of the label shall be per the above drawing)

Type name, Resistance value and quantity are filled in. Note 4.

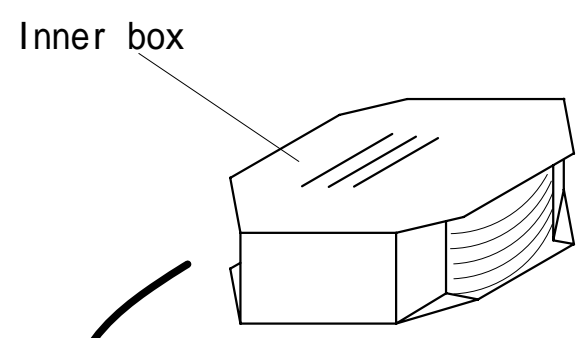

Put the inner box into the outer box.

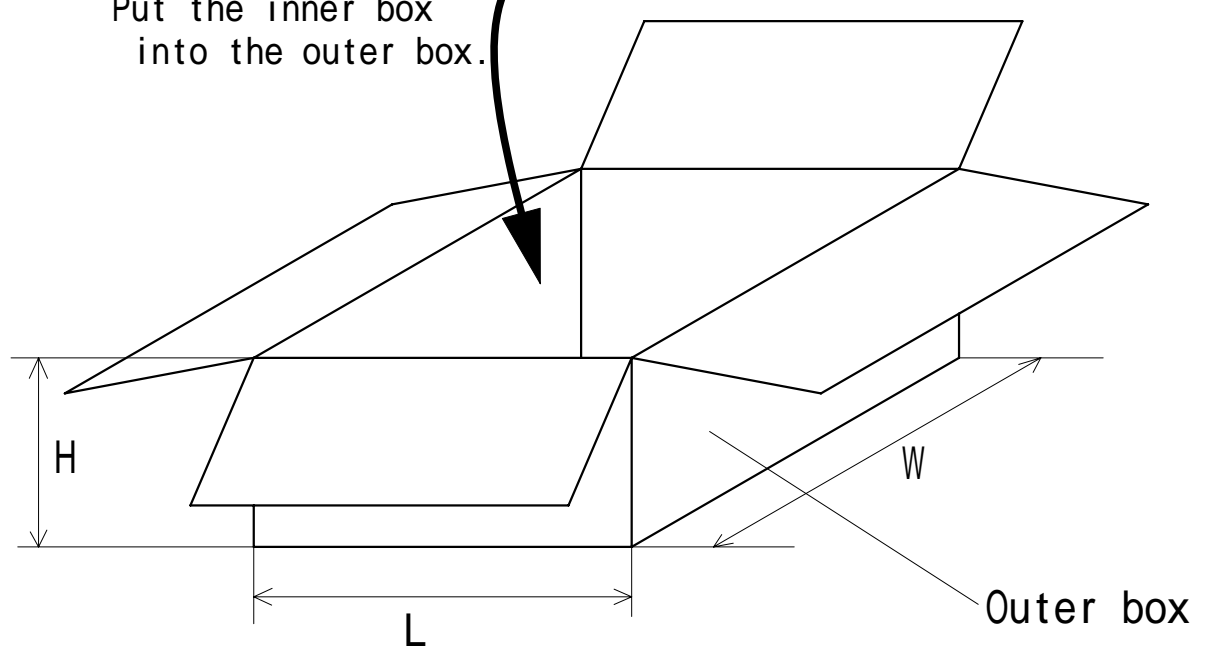

Outer box

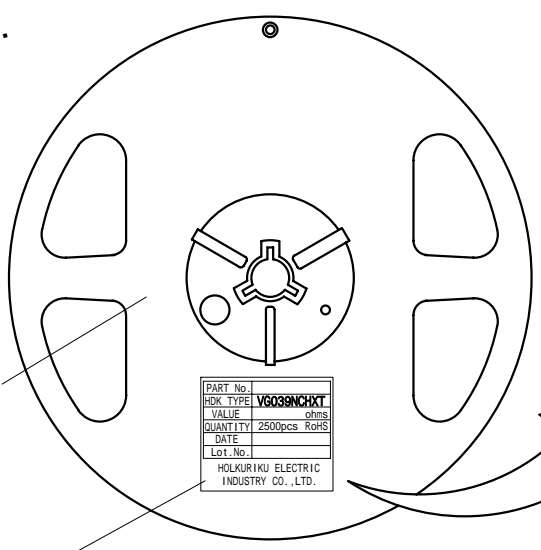

PART No.	
HDK TYPE	VG039NCHXT
VALUE	ohms
QUANTITY	2500pcs RoHS
DATE	
Lot.No.	
HOKURIKU ELECTRIC INDUSTRY CO., LTD.	

Label description

PART No. : Per customer's directions
 VALUE : Indication of the resistance value (Ex. 100)
 QUANTITY : Label for the reel
 LEADLESS SOLDER : "RoHS"
 Date : Indication of taping date(Ex. 02.4.18)
 Lot.No. : Indication of HDK manufacturing lot No.(Ex. Q-16-5-1)

Packaging Specification

	Number of the reels put in	Total Quantity of the products
Inner box A	A max of 2 reels	5 000 pcs. max.
Inner box B	A max of 6 reels	15 000 pcs. max.

	Number of the reels put in	Total Quantity of the products	Size (W*L*H) (Unit : mm)
Outer box a	A max of 6 reels	15 000 pcs.max.	290*210*90
Outer box b	A max of 12 reels	30 000 pcs.max.	505*210*90
Outer box c	A max of 24 reels	60 000 pcs.max.	400*220*180
Outer box d	A max of 48 reels	120 000 pcs.max.	400*220*330
Outer box e	A max of 30 reels	75 000 pcs.max.	390*210*225

- Note 1- Glue the label on the reel (The gluing position is per the drawing.)
- Note 2- Cushion material is to be put in to fill the empty space when the number of the reels in an inner box does not reach 2 or 6 respectively.
- Note 3- Cushion material is to be put in to fill the empty space when the total quantity in the outer box does not reach 15 000 , 30 000 , 60 000, 75 000, or 120 000 pcs. respectively.
- Note 4- Type name, resistance value and quantity shall be written on a inner box.

Example : VG039NCHXT
 B 1 k ohm
 15 000

REVISIONS						
DRAWN N.Kurata	CHECKED	APPROVED H.Takabayashi	UNIT mm	SCALE 5/1	TITLE VARIABLE RESISTOR	HDK TYPE VG039NCHXT
DATE Oct.11,2006	DATE	DATE Oct.11,2006	HOKURIKU ELECTRIC INDUSTRY CO.,LTD.		HDK DWG No. R-2832	REV.
TOLERANCE UNLESS OTHERWISE SPECIFIED						

4 3 2 1

X-ON Electronics

Largest Supplier of Electrical and Electronic Components

Click to view similar products for [Trimmer Resistors - Through Hole](#) category:

Click to view products by [Hokuriku](#) manufacturer:

Other Similar products are found below :

[64W205](#) [M63M101KB40](#) [M63M103KB40](#) [M63M203KB40](#) [M63X104KB40](#) [CT6P-103](#) [M63X102KB40](#) [CB10MV473ME](#) [4270W105K](#)
[82PR2KLFTB](#) [62MR100](#) [SK 104 25,4 STC TO 220](#) [72XWR20K](#) [9702-2SL-1](#) [78SR5K](#) [CT15NV15103M](#) [78SBWR1K](#) [343P10](#)
[404806412013](#) [PTC15NV02-104A2020](#) [PTC15LV02-103A2020](#) [PT15GV02-27402](#) [FT-63EP103](#) [RJ-5EW502](#) [ST15NV15-103A3030-E-PM-](#)
[S](#) [3059Y-1-200LF](#) [PT15NH05-103A2020-E-S](#) [PT10MH01-253A2020-E-PM-S](#) [PTC10MH05-103A2020](#) [RJ-5EW203](#) [RJ-5EW103](#) [FT-](#)
[63ES103](#) [RJ-13PR253](#) [RJ-6P503](#) [RJ-5EW204](#) [043414X](#) [099985D](#) [PV36W103C01B00](#) [PV37X104C01B00](#) [CN-15.1-100K](#) [CN-15.1-22K](#)
[CN-15.1-3K3](#) [CN-15.1-4M7](#) [R0141-2-100K](#) [R0141-2-10K](#) [R0141-2-20K](#) [1028F-500K](#) [R16148-1A-1-A22K](#) [R16148-1A-1-A2K2](#) [R16148-](#)
[1A-1-B1K](#)