

### Features

- Output voltage ranges: Fixed range of 1.8V, 2.5V, 2.7V, 3.0V, 3.3V, 5.0V type.
- Highly accuracy:  $\pm 2\%$
- Low voltage drop: 360mV (typ.),  $V_{OUT}=5.0V$  at 500mA
- Guaranteed output current: 500mA
- Low quiescent current: 4 $\mu$ A (typ.)
- Current limiting
- Over-temperature shutdown
- SOT23-5 and SOT89 Packages

### Applications

- Portable electronics
- Wireless devices
- Cordless phones
- PC peripherals
- Battery powered devices
- Electronic scales

### General Description

The HT78xx series of positive, linear regulators features low quiescent current (4 $\mu$ A typ.) with low dropout voltage, making them ideal for battery applications. The devices are capable of supplying 500mA of output current continuously.

They are available with several fixed output voltages ranging from 1.8V to 5.0V. Although designed primarily as fixed voltage regulators, these devices can be used with external components to obtain variable voltages and currents.

These rugged devices have Thermal Shutdown and Current Limiting to prevent device failure under the "Worst" of operating conditions.

### Selection Table

Part No.	Output Voltage	Tolerance	Package	Marking
HT7818	1.8V	$\pm 2\%$	SOT23-5 SOT89	78XX (for SOT23-5) HT78XX (for SOT89)
HT7825	2.5V			
HT7827	2.7V			
HT7830	3.0V			
HT7833	3.3V			
HT7850	5.0V			

Note: "xx" stands for output voltages.

### Block Diagram

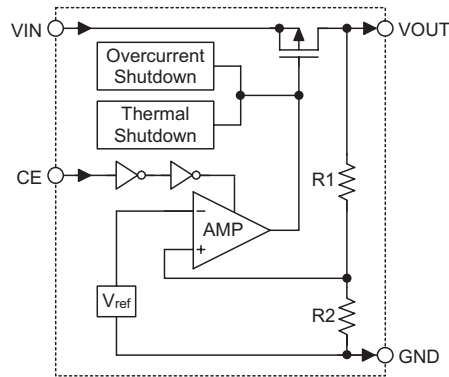

### Pin Assignment

SOT23-5

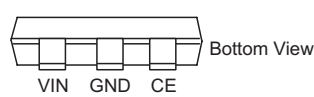
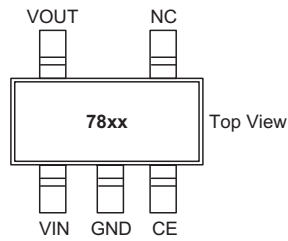

SOT89

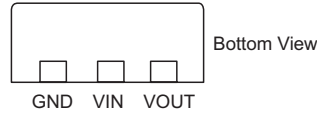
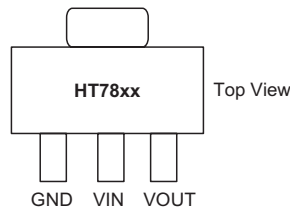

### Pin Description

Pin No.		Pin Name	Description
SOT23-5	SOT89		
3	—	CE	Chip enable pin, high enable
5	3	VOUT	Output pin
1	2	VIN	Input pin
2	1	GND	Ground pin
4	—	NC	No connection

## Absolute Maximum Ratings\*

Maximum Supply Voltage .....Up to 8.5V      Storage Temperature .....-50°C to 125°C  
 Operating Temperature .....-40°C to 85°C

Note: These are stress ratings only. Stresses exceeding the range specified under Absolute Maximum Ratings may cause substantial damage to the device. Functional operation of this device at other conditions beyond those listed in the specification is not implied and prolonged exposure to extreme conditions may affect device reliability.

\* Absolute maximum ratings indicate limits beyond which damage to the device may occur. Operating Ratings indicate conditions for which the device is intended to be functional, but do not guarantee specific performance limits.

The guaranteed specifications apply only for the test conditions listed.

## Thermal Information

Symbol	Parameter	Package	Max.	Unit
$\theta_{JA}$	Thermal Resistance (Junction to Ambient) (Assume no ambient airflow, no heat sink)	SOT23-5	500	°C/W
		SOT89	200	°C/W
$P_D$	Power Dissipation	SOT23-5	0.20	W
		SOT89	0.50	W

Note:  $P_D$  is measured at  $T_a = 25^\circ\text{C}$

## Electrical Characteristics

$T_j = 25^\circ\text{C}$ ,  $V_{IN} = V_{OUT} + 1.0\text{V}$ ,  $I_O = 1\text{mA}$ , unless otherwise specified

Symbol	Parameter	Test Conditions	Min.	Typ.	Max.	Unit	
$V_{IN}$	Input Voltage	—	—	—	8	V	
$\Delta V_{OUT}$	Output Voltage Tolerance	—	-2	—	2	%	
$I_{SS}$	Quiescent Current	$I_O = 0\text{mA}$ , $V_{CE} = V_{IN}$	—	4	7	$\mu\text{A}$	
$\Delta V_{LOAD}$	Load Regulation (Note1)	$1\text{mA} \leq I_{OUT} \leq 500\text{mA}$	—	0.004	0.008	%/mA	
$V_{DROP}$	Dropout Voltage (Note2)	$\Delta V_{OUT} = 2\%$ $I_{OUT} = 500\text{mA}$	$V_O \leq 1.8\text{V}$	—	800	1200	mV
			$2.5\text{V} \leq V_O \leq 2.7\text{V}$	—	500	650	
			$3.0\text{V} \leq V_O \leq 5.0\text{V}$	—	360	500	
$\Delta V_{LINE}$	Line Regulation	$V_{OUT} + 1.0\text{V} \leq V_{IN} \leq 8.0\text{V}$	—	0.2	0.3	%/V	
$I_{LIM}$	Current Limit (Note3)	$\Delta V_{OUT} = 10\%$	500	—	—	mA	
$V_{IH}$	CE Input High Threshold	$V_{OUT} + 1\text{V} \leq V_{IN} \leq 8\text{V}$	2	—	—	V	
$V_{IL}$	CE Input Low Threshold	$V_{OUT} + 1\text{V} \leq V_{IN} \leq 8\text{V}$	—	—	0.8	V	
$I_{SD}$	Shutdown Current	CE input voltage $\leq 0.8\text{V}$	—	0.5	1.0	$\mu\text{A}$	
$\frac{\Delta V_{OUT}}{\Delta T_a}$	Temperature Coefficient	$-40^\circ\text{C} < T_a < 85^\circ\text{C}$	—	$\pm 0.8$	—	mV/°C	

Note: 1. Load regulation is measured at a constant junction temperature, using pulse testing with a low ON time and is guaranteed up to the maximum power dissipation. Power dissipation is determined by the input/output differential voltage and the output current. Guaranteed maximum power dissipation will not be available over the full input/output range. The maximum allowable power dissipation at any ambient temperature is  $P_D = (T_{J(MAX)} - T_a) / \theta_{JA}$ .

2. Dropout voltage is defined as the input voltage minus the output voltage that produces a 2% change in the output voltage from the value at  $V_{IN} = V_{OUT} + 1\text{V}$  with a fixed load.

3. Current limit is measured by pulsing for a short time.

## Application Circuit

The circuits provided in this section are for reference only.

For the purposes of clarity some of the detailed components parameters shall depend on the application.

### Basic Circuits

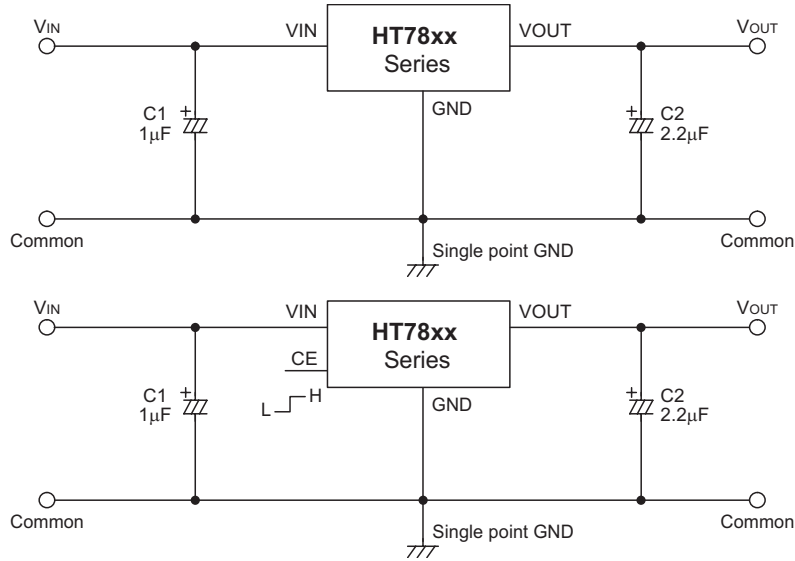

$\frac{R2}{R1}$

### Typical Application Circuits

#### High Output Current Positive Voltage Regulator

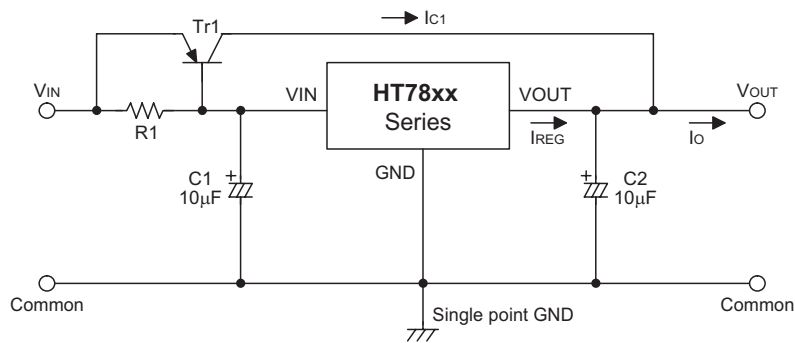

$$R1 = \frac{V_{BE1}}{I_{REG} - \frac{I_{C1}}{(1+\beta)}}$$

$$I_o = I_{C1} + I_{REG}$$

**Increased Output Voltage Circuit**

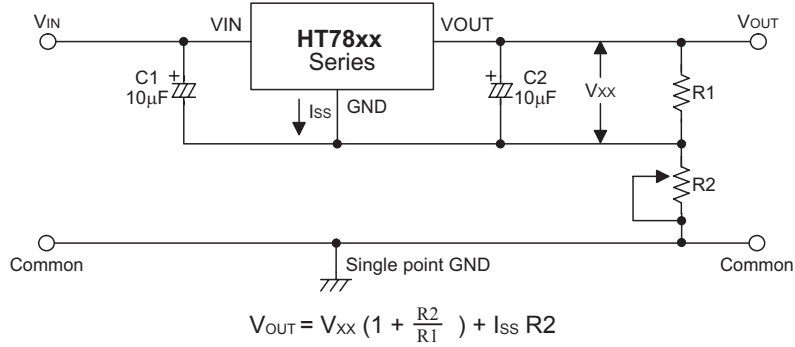

**Dual Supply Circuit**

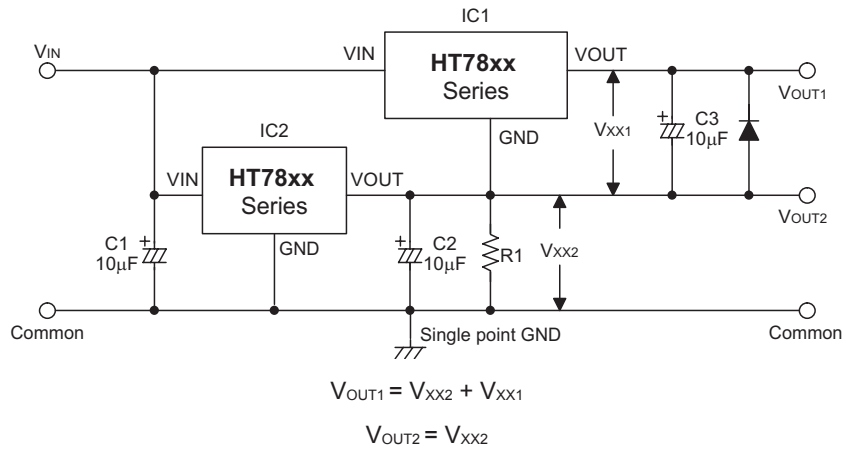

**Tracking Voltage Regulator**

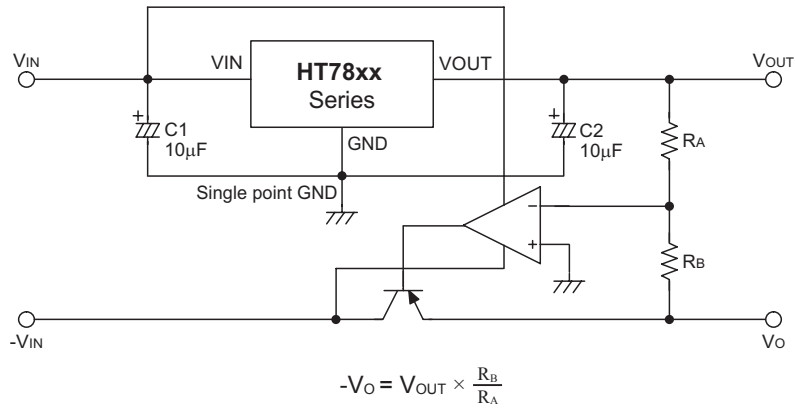

## Package Information

Note that the package information provided here is for consultation purposes only. As this information may be updated at regular intervals users are reminded to consult the [Holtek website](#) for the latest version of the [Package/ Carton Information](#).

Additional supplementary information with regard to packaging is listed below. Click on the relevant section to be transferred to the relevant website page.

- Package Information (include Outline Dimensions, Product Tape and Reel Specifications)
- The Operation Instruction of Packing Materials
- Carton information

## 5-pin SOT23-5 Outline Dimensions

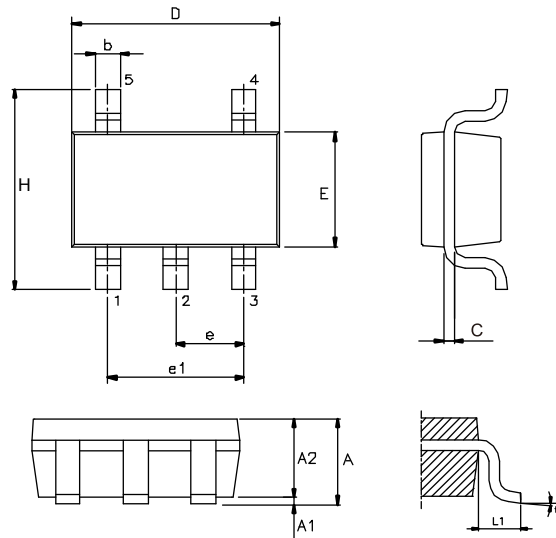

Symbol	Dimensions in inch		
	Min.	Nom.	Max.
A	0.030	—	0.031
A1	0.000	—	0.002
A2	0.028	0.030	0.031
b	0.014	—	0.020
C	0.004	—	0.008
D	—	0.114 BSC	—
E	—	0.110 BSC	—
E1	—	0.063 BSC	—
e	—	0.037 BSC	—
e1	—	0.075 BSC	—
L	0.015	0.018	0.024
L1	—	0.024 BSC	—
θ	0°	—	8°

Symbol	Dimensions in mm		
	Min.	Nom.	Max.
A	0.75	—	0.80
A1	0.00	—	0.05
A2	0.70	0.75	0.78
b	0.35	—	0.50
C	0.10	—	0.20
D	—	2.90 BSC	—
E	—	2.80 BSC	—
E1	—	1.60 BSC	—
e	—	0.95 BSC	—
e1	—	1.90 BSC	—
L	0.37	0.45	0.60
L1	—	0.60 BSC	—
θ	0°	—	8°

## 3-pin SOT89 Outline Dimensions

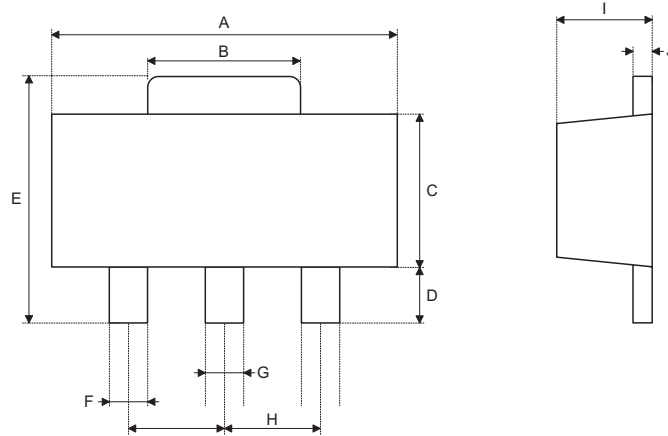

Symbol	Dimensions in inch		
	Min.	Nom.	Max.
A	0.173	—	0.181
B	0.053	—	0.072
C	0.090	—	0.102
D	0.035	—	0.047
E	0.155	—	0.167
F	0.014	—	0.019
G	0.017	—	0.022
H	—	0.059 BSC	—
I	0.055	—	0.063
J	0.014	—	0.017

Symbol	Dimensions in mm		
	Min.	Nom.	Max.
A	4.40	—	4.60
B	1.35	—	1.83
C	2.29	—	2.60
D	0.89	—	1.20
E	3.94	—	4.25
F	0.36	—	0.48
G	0.44	—	0.56
H	—	1.50 BSC	—
I	1.40	—	1.60
J	0.35	—	0.44



Copyright© 2016 by HOLTEK SEMICONDUCTOR INC.

The information appearing in this Data Sheet is believed to be accurate at the time of publication. However, Holtek assumes no responsibility arising from the use of the specifications described. The applications mentioned herein are used solely for the purpose of illustration and Holtek makes no warranty or representation that such applications will be suitable without further modification, nor recommends the use of its products for application that may present a risk to human life due to malfunction or otherwise. Holtek's products are not authorized for use as critical components in life support devices or systems. Holtek reserves the right to alter its products without prior notification. For the most up-to-date information, please visit our web site at <http://www.holtek.com.tw>.

## X-ON Electronics

Largest Supplier of Electrical and Electronic Components

*Click to view similar products for [LDO Voltage Regulators](#) category:*

*Click to view products by [Holtek](#) manufacturer:*

Other Similar products are found below :

[AP7363-SP-13](#) [L79M05TL-E](#) [AP7362-HA-7](#) [PT7M8202B12TA5EX](#) [TCR3DF185,LM\(CT](#) [TCR3DF45,LM\(CT](#) [TLE4473G V52](#) [059985X](#)  
[NCP4687DH15T1G](#) [701326R](#) [NCV8170AXV250T2G](#) [SCD337BTG](#) [AP7315-25W5-7](#) [AP2111H-1.2TRG1](#) [ZLDO1117QK50TC](#) [AZ1117ID-](#)  
[ADJTRG1](#) [TCR3DG12,LF](#) [MIC5514-3.3YMT-T5](#) [SCD7912BTG](#) [NCP154MX180270TAG](#) [SCD33269T-5.0G](#) [NCV8170BXV330T2G](#)  
[NCV8170BMX330TCG](#) [NCV8170AMX120TCG](#) [NCP706ABMX300TAG](#) [NCP153MX330180TCG](#) [NCP114BMX075TCG](#) [MC33269T-3.5G](#)  
[CAT6243-ADJCMT5T](#) [TCR3DG33,LF](#) [TCR4DG35,LF](#) [TAR5S15U\(TE85L,F\)](#) [TAR5S18U\(TE85L,F\)](#) [TCR3UG19A,LF](#) [TCR4DG105,LF](#)  
[MPQ2013AGG-5-P](#) [NCV8170AMX360TCG](#) [TLE4268GSXUMA2](#) [NCP715SQ15T2G](#) [MIC5317-3.0YD5-T5](#) [NCV563SQ18T1G](#)  
[NCP715MX30TBG](#) [NCV8702MX25TCG](#) [NCV8170BXV120T2G](#) [MIC5317-1.2YD5-T5](#) [NCV8170AMX150TCG](#) [NCV8170BMX150TCG](#)  
[AP2213D-3.3TRG1](#) [NCV8170BMX120TCG](#) [NCV8170BMX310TCG](#)