

ABP SERIES

32305128
Issue G

Basic Board Mount Pressure Sensors

High Accuracy, Compensated/Amplified
60 mbar to 10 bar | 6 kPa to 1 MPa | 1 psi to 150 psi
Digital or Analog Output, Liquid Media Capable

DESCRIPTION

The ABP Series are piezoresistive silicon pressure sensors offering a ratiometric analog or digital output for reading pressure over the specified full scale pressure span and temperature range. They are calibrated and temperature compensated for sensor offset, sensitivity, temperature effects and accuracy errors (which include non-linearity, repeatability and hysteresis) using an on-board Application Specific Integrated Circuit (ASIC). Calibrated output values for pressure are updated at approximately 1 kHz for analog and 2 kHz for digital. All products are designed and manufactured according to ISO 9001 standards.

- Dry gases option: The input port is limited to non-corrosive, non-ionic media (e.g., dry air, gases) and should not be exposed to condensation. The gases are limited to media compatible with high temperature polyamide, silicone, alumina ceramic, silicon, gold, and glass.
- Liquid media option: Includes an additional silicone-based gel coating to protect the electronics under port P1, which enables use with non-corrosive liquids (e.g. water and saline) and in applications where condensation can occur. Since port P2 is designed for use with non-corrosive liquids, this option is often suitable for wet-wet differential sensing.

DIFFERENTIATION

- Enhanced accuracy helps the design engineer fully understand the error in measurement.
- Wide supply voltage range offers design flexibility.
- Power consumption when utilizing sleep mode option allows for use in battery-powered applications.

VALUE TO CUSTOMERS

- Simplifies design-in: Small size saves room on the PC board (PCB), or simplifies design in smaller and lower power devices. Meets Moisture Sensitivity Level 1 requirements, which allows for unlimited shelf life when stored at <30 °C/85 %RH and, under most storage conditions, allows for PCB soldering without any material concern about solder joint quality due

to aging of the sensor terminals, which minimizes the concern about aging of the terminals prior PCB assembly. Pressure choices allow engineers to select range required for their application. Leadless SMT, SMT, and DIP package options.

- Cost-effective: Small size helps engineers reduce design and manufacturing costs while maintaining enhanced performance and reliability of the systems they design.
- Accurate: Total Error Band (TEB) and wide pressure range enable engineers to optimize system performance by improving resolution and system accuracy. Optional internal diagnostics validate that the sensor readings are correct.
- Flexible: Supply voltage range, variety of pressure units, types, and ranges, output options, and wide operating temperature range simplify use in the application.
- Versatile: Wet-media compatibility, sleep mode, and temperature output options make the sensor a versatile choice for Internet of Things applications.
- Honeywell Brand: Utilize proprietary Honeywell technology, and are protected by multiple global patents.
- Food Safety Certification for North America, Europe and Asia.

POTENTIAL APPLICATIONS

- **Medical:** CPAP, blood analysis, blood pressure monitoring, breast pumps, drug dosing, hospital beds, massage machines, oxygen concentrators, patient monitoring, sleep apnea equipment, urine analyzers, ventilators/portable ventilators, and wound therapy
- **Industrial:** Air brakes, HVAC/transmitters, life sciences, material handling, pneumatic control and regulation, process gas monitoring, and valve positioning/positioners
- **Commercial:** Air beds, coffee makers, and washing machines



FEATURES

- Measures gage and differential pressures
- Total Error Band (see Figure 1): $\pm 1.5\%$ FSS
- Liquid media option: Allows for wet/wet operation on dual ported devices
- Industry-leading long-term stability: $\pm 0.25\%$ FSS
- Industry-leading accuracy: $\pm 0.25\%$ FSS BFLS
- Wide pressure range: 60 mbar to 10 bar | 6 kPa to 1 MPa | 1 psi to 150 psi
- As small as 8 mm x 7 mm
- High burst pressures (see Table 7)
- Calibrated over temperature range of 0°C to 50°C [32°F to 122°F]
- Operates from a single power supply of either 3.3 Vdc or 5.0 Vdc
- Output: Ratiometric analog or I²C- or SPI-compatible 12-bit digital
- Power consumption: 2 μ A typical when utilizing sleep mode option
- Meets IPC/JEDEC J-STD-020D.1 Moisture Sensitivity Level 1 requirements
- REACH and RoHS compliant
- Options: Internal diagnostic function, liquid media, sleep mode, temperature output
- Sensor materials have been tested and certified for these food safety standards:
 - NSF-169
 - BPA Free
 - LFGB



PORTFOLIO

Honeywell offers a variety of board mount pressure sensors for potential use in medical and industrial applications. To view the entire product portfolio, [click here](#).



BASIC BOARD MOUNT PRESSURE SENSORS, ABP SERIES

FIGURE 1. TOTAL ERROR BAND

Total Error Band (TEB) is a single specification that includes all possible sources of error. TEB should not be confused with accuracy, which is actually a component of TEB. TEB is the worst error that the sensor could experience. The TEB specification on a datasheet may be confusing. Honeywell uses the TEB specification in its datasheet because it is the most comprehensive measurement of a sensor's true accuracy. Honeywell also provides the accuracy specification in order to provide a common comparison with competitors' literature that does not use the TEB specification. Many competitors do not use TEB—they simply specify the accuracy of their device. Their accuracy specification, however, may exclude certain parameters. On their datasheet, the errors are listed individually. When combined, the total error (or what would be TEB) can be significant.

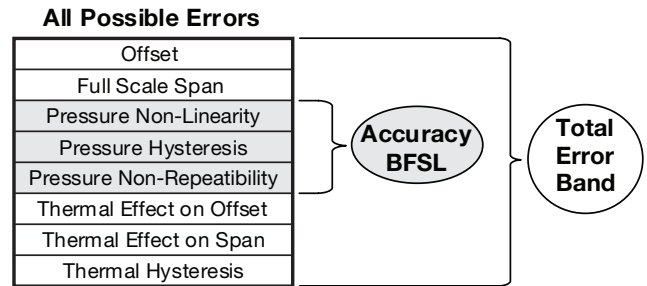

TABLE 1. ABSOLUTE MAXIMUM RATINGS¹

| CHARACTERISTIC | MIN. | MAX. | UNIT |
|---|-----------|----------------------------|---------|
| Supply voltage (V_{supply}) | -0.3 | 6.0 | Vdc |
| Voltage on any pin | -0.3 | $V_{supply} + 0.3$ | V |
| Digital interface clock frequency: | | | |
| I ² C | 100 | 400 | kHz |
| SPI | 50 | 800 | |
| ESD susceptibility (human body model) | 2 | — | kV |
| Storage temperature | -40 [-40] | 85 [185] | °C [°F] |
| Soldering time and temperature: | | | |
| lead solder temperature (DIP) | | 4 s max. at 250°C [482°F] | |
| peak reflow temperature (Leadless SMT, SMT) | | 15 s max. at 250°C [482°F] | |

¹Absolute maximum ratings are the extreme limits the device will withstand without damage.

TABLE 2. ENVIRONMENTAL SPECIFICATIONS

| CHARACTERISTIC | PARAMETER |
|---|---|
| Humidity: | |
| all external surfaces | 0 %RH to 95 %RH, non-condensing |
| internal surfaces of Liquid Media Option (T, V, B, C, F, G) | 0 %RH to 100 %RH, condensing |
| internal surfaces of Dry Gases Option (N, D) | 0 %RH to 95 %RH, non-condensing |
| Vibration | 15 g, 10 Hz to 2 kHz |
| Shock | 100 g, 6 ms duration |
| Life ¹ | 1 million pressure cycles minimum |
| Solder reflow | J-STD-020-D.1 Moisture Sensitivity Level 1 (unlimited shelf life when stored at ≤30°C/85 %RH) |
| Certification (silicone gel coating option: Port 1 only) | NSF-169, BPA Free, LFGB |

¹Life may vary depending on specific application in which the sensor is used.

TABLE 3. WETTED MATERIALS¹

| COMPONENT | PRESSURE PORT 1 (P1) | | PRESSURE PORT 2 (P2) |
|-----------------------|--------------------------------|---------------------|----------------------|
| | DRY GAS OPTION | LIQUID MEDIA OPTION | |
| Ports and covers | high temperature polyamide | | |
| Metal gel ring | — | 304 SST | — |
| Substrate | alumina ceramic | — | alumina ceramic |
| Adhesives | epoxy, silicone | epoxy, silicone gel | epoxy, silicone |
| Electronic components | silicon, glass, gold, aluminum | — | silicon |

¹Contact Honeywell Customer Service for detailed material information.

TABLE 4. SENSOR PRESSURE TYPES

| PRESSURE TYPE | DESCRIPTION |
|---------------|--|
| Gage | Output is proportional to the difference between applied pressure and atmospheric (ambient) pressure. |
| Differential | Output is proportional to the difference between the pressures applied to each port (Port 1 – Port 2). |

BASIC BOARD MOUNT PRESSURE SENSORS, ABP SERIES

TABLE 5. OPERATING SPECIFICATIONS

| CHARACTERISTIC | ANALOG | | | DIGITAL | | | UNIT |
|---|-------------|-----------------|-----------------|-------------|-----------------|------------------|-------------------|
| | MIN. | TYP. | MAX. | MIN. | TYP. | MAX. | |
| Supply voltage (V_{supply}): ^{1,2,3} 3.3 Vdc 5.0 Vdc | 3.0 4.75 | 3.3 5.0 | 3.6 5.25 | 3.0 4.75 | 3.3 5.0 | 3.6 5.25 | Vdc |
| Supply current: 3.3 Vdc 5.0 Vdc sleep mode option | — — — | 2.1 2.7 — | 2.8 3.8 — | — — — | 3.1 3.7 1 | 3.9 4.6 10 | mA mA μA |
| Operating temperature range ⁴ | -40 [-40] | — | 85 [185] | -40 [-40] | — | 85 [185] | °C [°F] |
| Compensated temperature range ⁵ | 0 [-32] | — | 50 [122] | 0 [-32] | — | 50 [122] | °C [°F] |
| Temperature output option ⁶ | — | — | — | — | ±4 | — | °C |
| Startup time (power up to data ready) | — | — | 5 | — | — | 3 | ms |
| Response time | — | 1 | — | — | 0.46 | — | ms |
| Clipping limit: upper lower | — 2.5 | — — | 97.5 — | — — | — — | — — | %Vsupply |
| I ² C/SPI voltage level: low high | — — | — — | — — | — 80 | — — | 20 — | %Vsupply |
| Pull up on SDA/MISO, SCL/SCLK, SS | — | — | — | 1 | — | — | kOhm |
| Total Error Band ⁷ | — | — | ±1.5 | — | — | ±1.5 | %FSS ⁸ |
| Accuracy ⁹ | — | — | ±0.25 | — | — | ±0.25 | %FSS BFSL |
| Long term stability (1000 hr, 25°C [77°F]) | — | — | ±0.25 | — | — | ±0.25 | %FSS |
| Output resolution | 0.03 — | — — | — — | — 12 | — — | — — | %FSS bits |

¹Sensors are either 3.3 Vdc or 5.0 Vdc based on the catalog listing selected.

²Ratiometricity of the sensor (the ability of the device output to scale to the supply voltage) is achieved within the specified operating voltage.

³The sensor is not reverse polarity protected. Incorrect application of supply voltage or ground to the wrong pin may cause electrical failure.

⁴Operating temperature range: The temperature range over which the sensor will produce an output proportional to pressure.

⁵Compensated temperature range: The temperature range over which the sensor will produce an output proportional to pressure within the specified performance limits.

⁶Temperature output option: Typical temperature output error over the compensated temperature range of 0°C to 50°C. Operation in Sleep Mode may affect temperature output error depending on duty cycle.

⁷Total Error Band: The maximum deviation from the ideal transfer function over the entire compensated temperature and pressure range. Includes all errors due to offset, full scale span, pressure non-linearity, pressure hysteresis, repeatability, thermal effect on offset, thermal effect on span, and thermal hysteresis.

⁸Full Scale Span (FSS): The algebraic difference between the output signal measured at the maximum (Pmax.) and minimum (Pmin.) limits of the pressure range. (See Figure 2.)

⁹Accuracy: The maximum deviation in output from a Best Fit Straight Line (BFSL) fitted to the output measured over the pressure range at 25°C [77°F]. Includes all errors due to pressure non-linearity, pressure hysteresis, and non-repeatability.

TABLE 6. SENSOR OUTPUT AT SIGNIFICANT PERCENTAGES (DIGITAL VERSIONS ONLY)

| % OUTPUT | DIGITAL COUNTS | |
|----------|----------------|--------|
| | DECIMAL | HEX |
| 0 | 0 | 0x0000 |
| 10 | 1638 | 0x0666 |
| 50 | 8192 | 0x2000 |
| 90 | 14746 | 0x399A |
| 100 | 16383 | 0x3FFF |

BASIC BOARD MOUNT PRESSURE SENSORS, ABP SERIES

FIGURE 2. TRANSFER FUNCTION LIMITS¹

Analog Versions

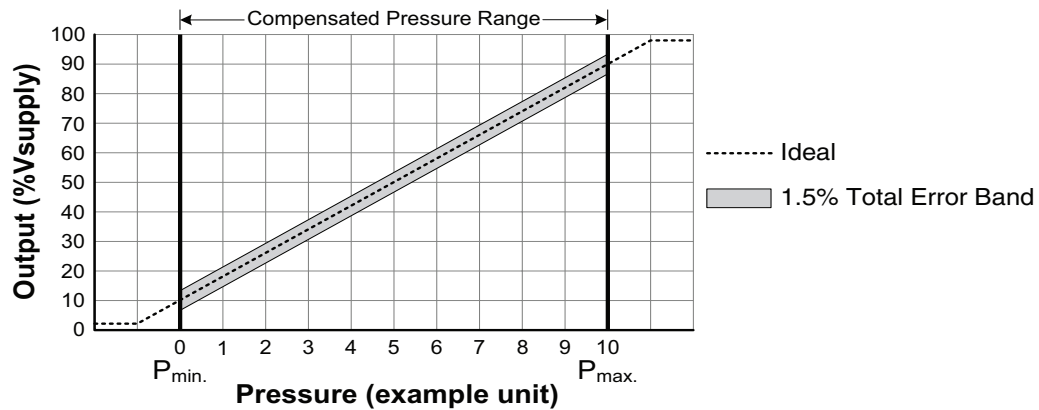

$$\text{Output (V)} = \frac{0.8 \times V_{\text{supply}}}{P_{\text{max.}} - P_{\text{min.}}} \times (\text{Pressure}_{\text{applied}} - P_{\text{min.}}) + 0.10 \times V_{\text{supply}}$$

Digital Versions



$$\text{Output (\% of } 2^{14} \text{ counts)} = \frac{80\%}{P_{\text{max.}} - P_{\text{min.}}} \times (\text{Pressure}_{\text{applied}} - P_{\text{min.}}) + 10\%$$

¹Transfer Function "A" is shown. See Figure 3 for other available transfer functions.

BASIC BOARD MOUNT PRESSURE SENSORS, ABP SERIES

FIGURE 3. NOMENCLATURE AND ORDER GUIDE

For example, **ABPDNNN150PGAA3** defines an ABP Series Amplified Basic Pressure Sensor, DIP package, NN pressure port, dry gases only, no diagnostics, 150 psi gage pressure range, analog output type, 10% to 90% of V_{supply} (analog), transfer function, no temperature output, no sleep mode, 3.3 Vdc supply voltage.

Product Series

ABP Amplified Basic

Package

D DIP (Dual Inline Pin)

M SMT (Surface Mount Technology)

L Leadless SMT

Pressure Port

| DIP | SMT | Leadless SMT |
|---|---|--|
| NN No port | NN No port | NN No port |
| AN Single axial barbed port | AN Single axial barbed port | AN Single axial barbed port |
| LN Single axial barbless port | LN Single axial barbless port | LN Single axial barbless port |
| JN Single radial barbless port | JN Single radial barbless port | — |
| JJ Dual radial barbless ports, same side | JJ Dual radial barbless ports, same side | — |
| RN Single radial barbed port | RN Single radial barbed port | — |
| RR Dual radial barbed ports, same side | RR Dual radial barbed ports, same side | — |

Supply Voltage

3 3.3 Vdc

5 5.0 Vdc

Transfer Function³

A 10% to 90% of V_{supply} (analog), 2¹⁴ counts (digital) no temperature output, no sleep mode

D 10% to 90% of 2¹⁴ counts (digital only) temperature output enabled, sleep mode enabled

S 10% to 90% of 2¹⁴ counts (digital only) no temperature output, sleep mode enabled

T 10% to 90% of 2¹⁴ counts (digital only) temperature output enabled, no sleep mode

Output Type

| | |
|---|---|
| A Analog | 3 I ² C, Address 0x38 |
| S SPI | 4 I ² C, Address 0x48 |
| 0 I ² C, Address 0x08 | 5 I ² C, Address 0x58 |
| 1 I ² C, Address 0x18 | 6 I ² C, Address 0x68 |
| 2 I ² C, Address 0x28 | 7 I ² C, Address 0x78 |

Pressure Range^{1,2}

| 60 mbar to 10 bar | | 6 kPa to 1 MPa | | 1 psi to 150 psi | |
|---------------------------------|-------------------------------|-------------------------------|--|------------------|--|
| Differential | | Differential | | Differential | |
| 060MD ±60 mbar | 006KD ±6 kPa | 001PD ±1 psi | | | |
| 100MD ±100 mbar | 010KD ±10 kPa | 005PD ±5 psi | | | |
| 160MD ±160 mbar | 016KD ±16 kPa | 015PD ±15 psi | | | |
| 250MD ±250 mbar | 025KD ±25 kPa | 030PD ±30 psi | | | |
| 400MD ±400 mbar | 040KD ±40 kPa | 060PD ±60 psi | | | |
| 600MD ±600 mbar | 060KD ±60 kPa | | | | |
| 001BD ±1 bar | 100KD ±100 kPa | | | | |
| 1.6BD ±1.6 bar | 160KD ±160 kPa | | | | |
| 2.5BD ±2.5 bar | 250KD ±250 kPa | | | | |
| 004BD ±4 bar | 400KD ±400 kPa | | | | |
| Gage | | Gage | | Gage | |
| 060MG 0 mbar to 60 mbar | 006KG 0 kPa to 6 kPa | 001PG 0 psi to 1 psi | | | |
| 100MG 0 mbar to 100 mbar | 010KG 0 kPa to 10 kPa | 005PG 0 psi to 5 psi | | | |
| 160MG 0 mbar to 160 mbar | 016KG 0 kPa to 16 kPa | 015PG 0 psi to 15 psi | | | |
| 250MG 0 mbar to 250 mbar | 025KG 0 kPa to 25 kPa | 030PG 0 psi to 30 psi | | | |
| 400MG 0 mbar to 400 mbar | 040KG 0 kPa to 40 kPa | 060PG 0 psi to 60 psi | | | |
| 600MG 0 mbar to 600 mbar | 060KG 0 kPa to 60 kPa | 100PG 0 psi to 100 psi | | | |
| 001BG 0 bar to 1 bar | 100KG 0 kPa to 100 kPa | 150PG 0 psi to 150 psi | | | |
| 1.6BG 0 bar to 1.6 bar | 160KG 0 kPa to 160 kPa | | | | |
| 2.5BG 0 bar to 2.5 bar | 250KG 0 kPa to 250 kPa | | | | |
| 004BG 0 bar to 4 bar | 400KG 0 kPa to 400 kPa | | | | |
| 006BG 0 bar to 6 bar | 600KG 0 kPa to 600 kPa | | | | |
| 010BG 0 bar to 10 bar | 001GG 0 kPa to 1 MPa | | | | |

Option

N Dry gases only, no diagnostics

D Dry gases only, diagnostics on

T Liquid media, no diagnostics

V Liquid media, diagnostics on

B Liquid media, food grade gel, no diagnostics⁴

C Liquid media, food grade gel, diagnostics on⁴

F Liquid media, fluorosilicone gel, no diagnostics⁴

G Liquid media, fluorosilicone gel, diagnostics on⁴

¹ Custom pressure ranges are available. Contact Honeywell Customer Service for more information.

² See the explanation of sensor pressure types in Table 4.

³ The Transfer Function limits define the output of the sensor at a given pressure input. By specifying P_{min} and P_{max}, the output at P_{min} and P_{max}, the complete transfer function of the sensor is defined. See the graphical representations of the transfer function in Figure 3.

⁴ Custom gel options are available. Contact Honeywell Customer Service for more information.

BASIC BOARD MOUNT PRESSURE SENSORS, ABP SERIES

TABLE 7. PRESSURE RANGE SPECIFICATIONS

| PRESSURE RANGE (SEE FIGURE 3.) | PRESSURE RANGE | | UNIT | OVERPRESSURE ¹ | | BURST PRESSURE ² | | COMMON MODE PRESSURE ³ |
|-----------------------------------|----------------|-------|------|---------------------------|-------------|-----------------------------|-------------|-----------------------------------|
| | PMIN. | PMAX. | | PORT 1 (P1) | PORT 2 (P2) | PORT 1 (P1) | PORT 2 (P2) | |
| 1 psi to 150 psi | | | | | | | | |
| Differential | | | | | | | | |
| 060MD | -60 | 60 | mbar | 2000 | 850 | 3500 | 1000 | 10000 |
| 100MD | -100 | 100 | mbar | 4000 | 1400 | 7000 | 2500 | 10000 |
| 160MD | -160 | 160 | mbar | 4000 | 1400 | 7000 | 2500 | 10000 |
| 250MD | -250 | 250 | mbar | 10000 | 2000 | 19000 | 4000 | 10000 |
| 400MD | -400 | 400 | mbar | 10000 | 2000 | 19000 | 4000 | 10000 |
| 600MD | -600 | 600 | mbar | 17000 | 2000 | 19000 | 4000 | 10000 |
| 001BD | -1 | 1 | bar | 17 | 4 | 19 | 8 | 17 |
| 1.6BD | -1.6 | 1.6 | bar | 17 | 8 | 19 | 16 | 17 |
| 2.5BD | -2.5 | 2.5 | bar | 17 | 8 | 19 | 16 | 17 |
| 004BD | -4.0 | 4.0 | bar | 17 | 16 | 19 | 19 | 17 |
| Gage | | | | | | | | |
| 060MG | 0 | 60 | mbar | 2000 | — | 3500 | — | 5500 |
| 100MG | 0 | 100 | mbar | 2000 | — | 3500 | — | 10000 |
| 160MG | 0 | 160 | mbar | 2000 | — | 3500 | — | 10000 |
| 250MG | 0 | 250 | mbar | 4000 | — | 7000 | — | 10000 |
| 400MG | 0 | 400 | mbar | 10000 | — | 19000 | — | 10000 |
| 600MG | 0 | 600 | mbar | 10000 | — | 19000 | — | 10000 |
| 001BG | 0 | 1 | bar | 17 | — | 19 | — | 17 |
| 1.6BG | 0 | 1.6 | bar | 17 | — | 19 | — | 17 |
| 2.5BG | 0 | 2.5 | bar | 17 | — | 19 | — | 17 |
| 004BG | 0 | 4 | bar | 17 | — | 19 | — | 17 |
| 006BG | 0 | 6 | bar | 17 | — | 19 | — | 17 |
| 010BG | 0 | 10 | bar | 17 | — | 19 | — | 17 |
| 6 kPa to 1 MPa | | | | | | | | |
| Differential | | | | | | | | |
| 006KD | -6 | 6 | kPa | 200 | 85 | 350 | 100 | 1000 |
| 010KD | -10 | 10 | kPa | 400 | 140 | 700 | 250 | 1000 |
| 016KD | -16 | 16 | kPa | 400 | 140 | 700 | 250 | 1000 |
| 025KD | -25 | 25 | kPa | 1000 | 200 | 1900 | 400 | 1000 |
| 040KD | -40 | 40 | kPa | 1000 | 200 | 1900 | 400 | 1000 |
| 060KD | -60 | 60 | kPa | 1700 | 200 | 1900 | 400 | 1000 |
| 100KD | -100 | 100 | kPa | 1700 | 400 | 1900 | 800 | 1700 |
| 160KD | -160 | 160 | kPa | 1700 | 800 | 1900 | 1600 | 1700 |
| 250KD | -250 | 250 | kPa | 1700 | 800 | 1900 | 1600 | 1700 |
| 400KD | -400 | 400 | kPa | 1700 | 1600 | 1900 | 1900 | 1700 |
| Gage | | | | | | | | |
| 006KG | 0 | 6 | kPa | 200 | — | 350 | — | 550 |
| 010KG | 0 | 10 | kPa | 200 | — | 350 | — | 1000 |
| 016KG | 0 | 16 | kPa | 200 | — | 350 | — | 1000 |
| 025KG | 0 | 25 | kPa | 400 | — | 700 | — | 1000 |
| 040KG | 0 | 40 | kPa | 1000 | — | 1900 | — | 1000 |
| 060KG | 0 | 60 | kPa | 1000 | — | 1900 | — | 1000 |
| 100KG | 0 | 100 | kPa | 1700 | — | 1900 | — | 1700 |
| 160KG | 0 | 160 | kPa | 1700 | — | 1900 | — | 1700 |
| 250KG | 0 | 250 | kPa | 1700 | — | 1900 | — | 1700 |
| 400KG | 0 | 400 | kPa | 1700 | — | 1900 | — | 1700 |
| 600KG | 0 | 600 | kPa | 1700 | — | 1900 | — | 1700 |
| 001GG | 0 | 1 | MPa | 1.7 | — | 1.9 | — | 1.7 |

BASIC BOARD MOUNT PRESSURE SENSORS, ABP SERIES

TABLE 7. PRESSURE RANGE SPECIFICATIONS (CONTINUED)

| PRESSURE RANGE (SEE FIGURE 3.) | PRESSURE RANGE | | UNIT | OVERPRESSURE ¹ | | BURST PRESSURE ² | | COMMON MODE PRESSURE ³ |
|-----------------------------------|----------------|-------|------|---------------------------|-------------|-----------------------------|-------------|-----------------------------------|
| | PMIN. | PMAX. | | Port 1 (P1) | Port 2 (P2) | Port 1 (P1) | Port 2 (P2) | |
| 1 psi to 150 psi | | | | | | | | |
| Differential | | | | | | | | |
| 001PD | -1 | 1 | psi | 30 | 10 | 50 | 15 | 150 |
| 005PD | -5 | 5 | psi | 150 | 30 | 275 | 40 | 150 |
| 015PD | -15 | 15 | psi | 250 | 60 | 275 | 120 | 250 |
| 030PD | -30 | 30 | psi | 250 | 120 | 275 | 240 | 250 |
| 060PD | -60 | 60 | psi | 250 | 250 | 275 | 275 | 250 |
| Gage | | | | | | | | |
| 001PG | 0 | 1 | psi | 30 | — | 50 | — | 150 |
| 005PG | 0 | 5 | psi | 150 | — | 275 | — | 150 |
| 015PG | 0 | 15 | psi | 250 | — | 275 | — | 250 |
| 030PG | 0 | 30 | psi | 250 | — | 275 | — | 250 |
| 060PG | 0 | 60 | psi | 250 | — | 275 | — | 250 |
| 100PG | 0 | 100 | psi | 250 | — | 275 | — | 250 |
| 150PG | 0 | 150 | psi | 250 | — | 275 | — | 250 |

¹Overpressure: The maximum pressure which may safely be applied to the product for it to remain in specification once pressure is returned to the operating pressure range. Exposure to higher pressures may cause permanent damage to the product. Unless otherwise specified this applies to all available pressure ports at any temperature with the operating temperature range.

²Burst pressure: The maximum pressure that may be applied to the specified port (P1 or P2) of the product without causing escape of pressure media. Product should not be expected to function after exposure to any pressure beyond the burst pressure.

³Common mode pressure: The maximum pressure that can be applied simultaneously to both ports of a differential pressure sensor without causing changes in specified performance.

FIGURE 4. RECOMMENDED FILTER CAP



*Analog output version only.

BASIC BOARD MOUNT PRESSURE SENSORS, ABP SERIES

FIGURE 5. DIP PACKAGE DIMENSIONAL DRAWINGS (FOR REFERENCE ONLY: MM [IN.])

DIP NN: No port

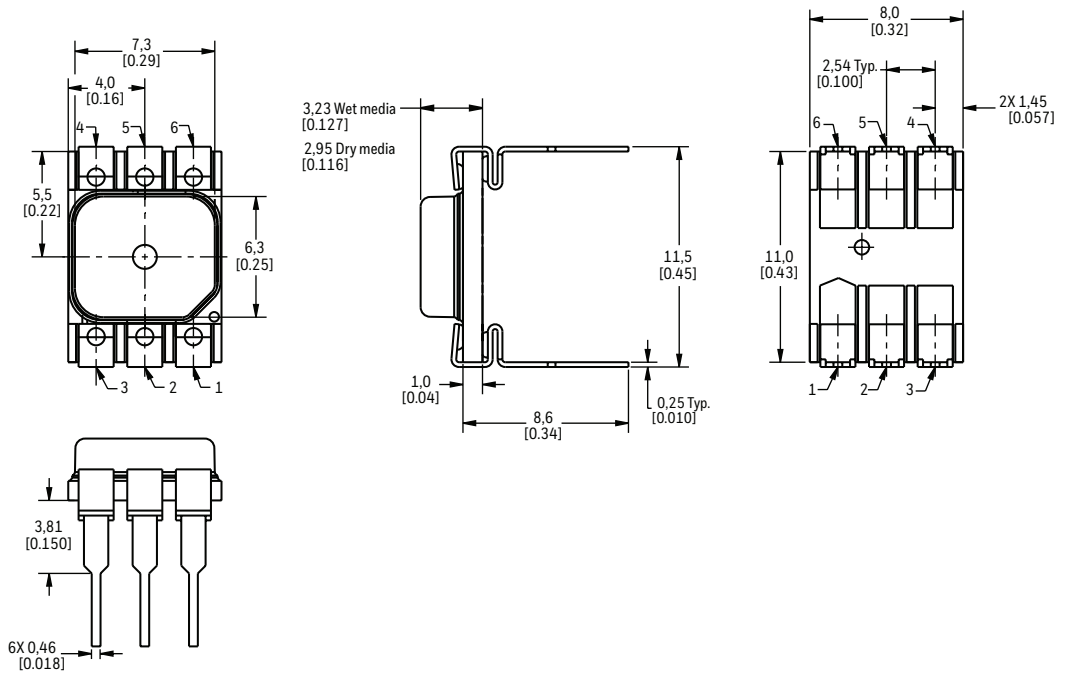
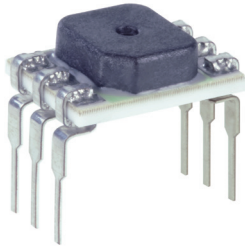

DIP AN: Single axial barbed port

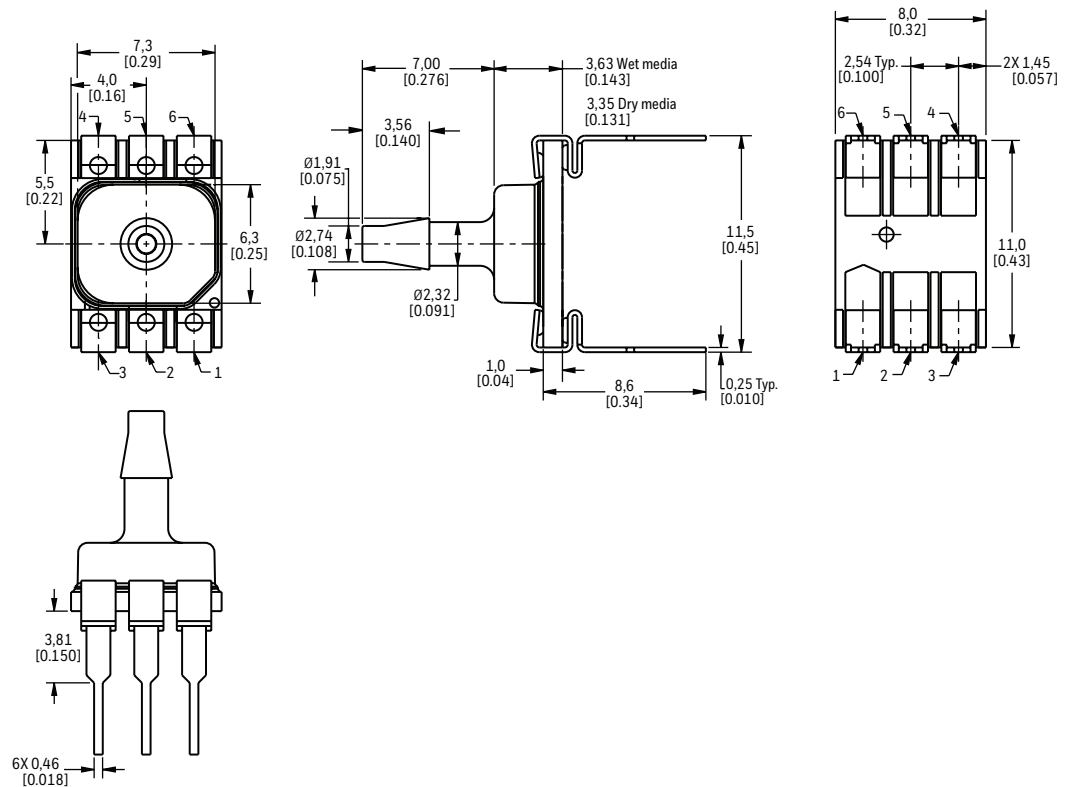
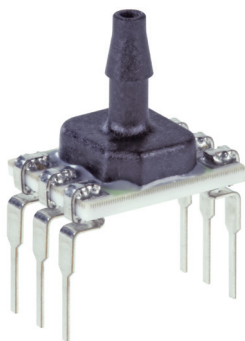

BASIC BOARD MOUNT PRESSURE SENSORS, ABP SERIES

FIGURE 5. DIP PACKAGE DIMENSIONAL DRAWINGS (CONTINUED)

DIP LN: Single axial barless port

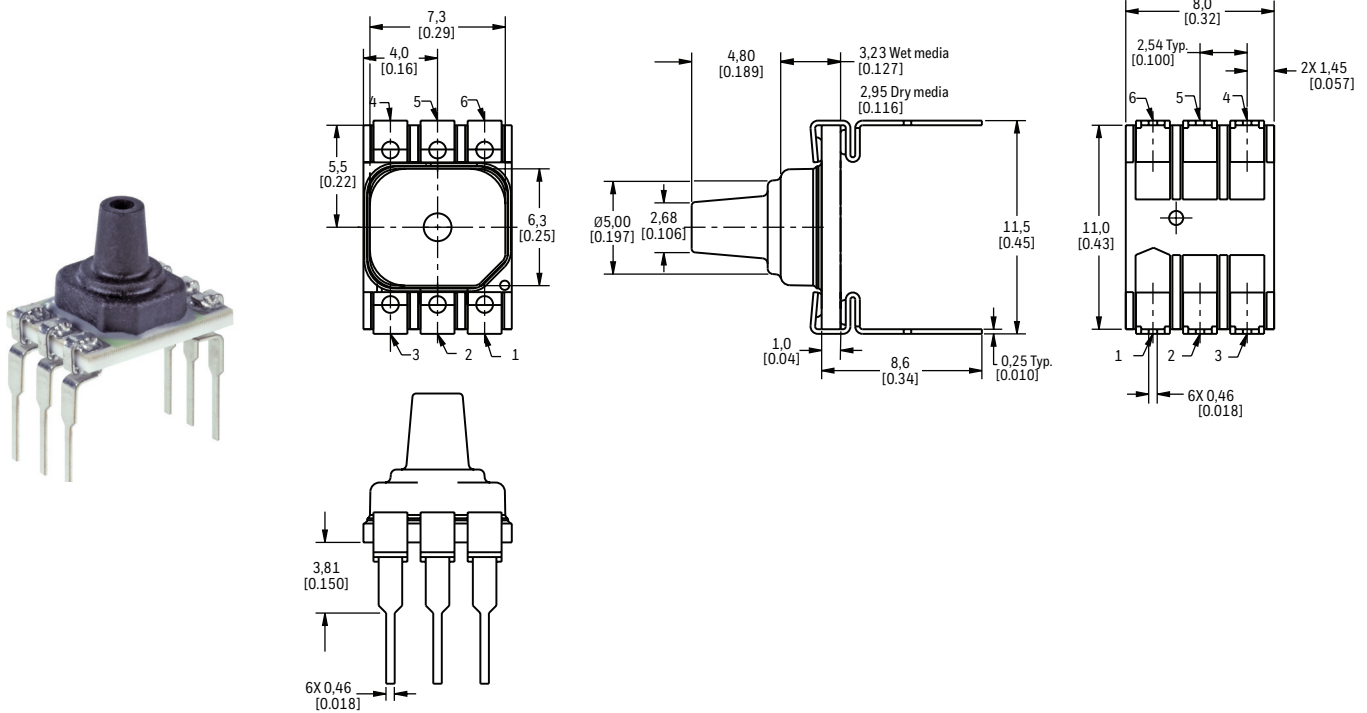

DIP JN: Single radial barless port



BASIC BOARD MOUNT PRESSURE SENSORS, ABP SERIES

FIGURE 5. DIP PACKAGE DIMENSIONAL DRAWINGS (CONTINUED)

DIP JJ: Dual radial barbless ports, same side

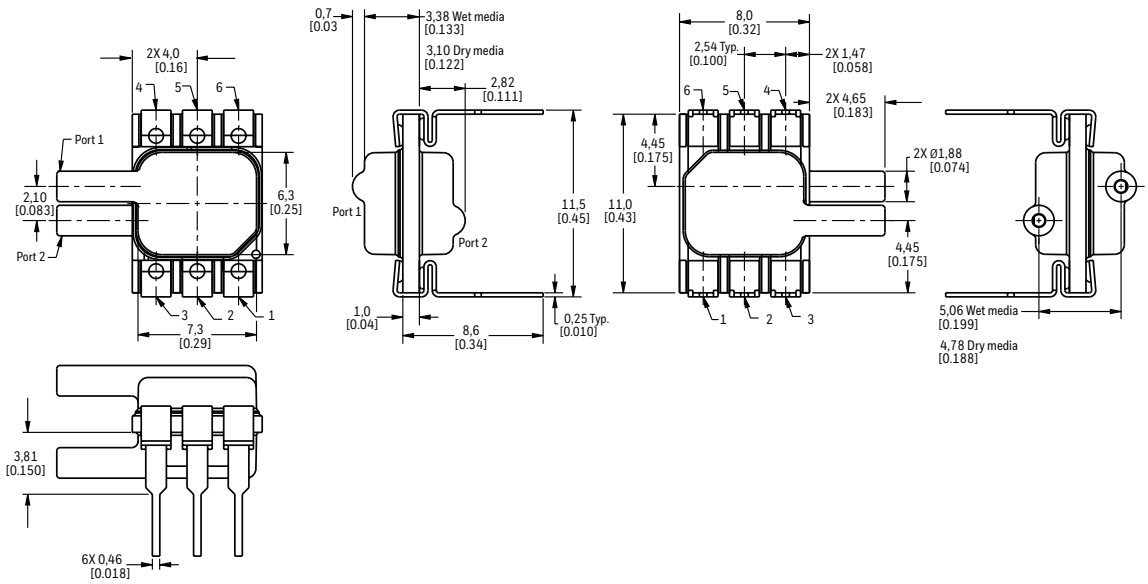
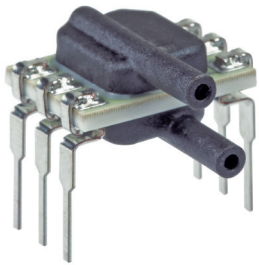

DIP RN: Single radial barbed port

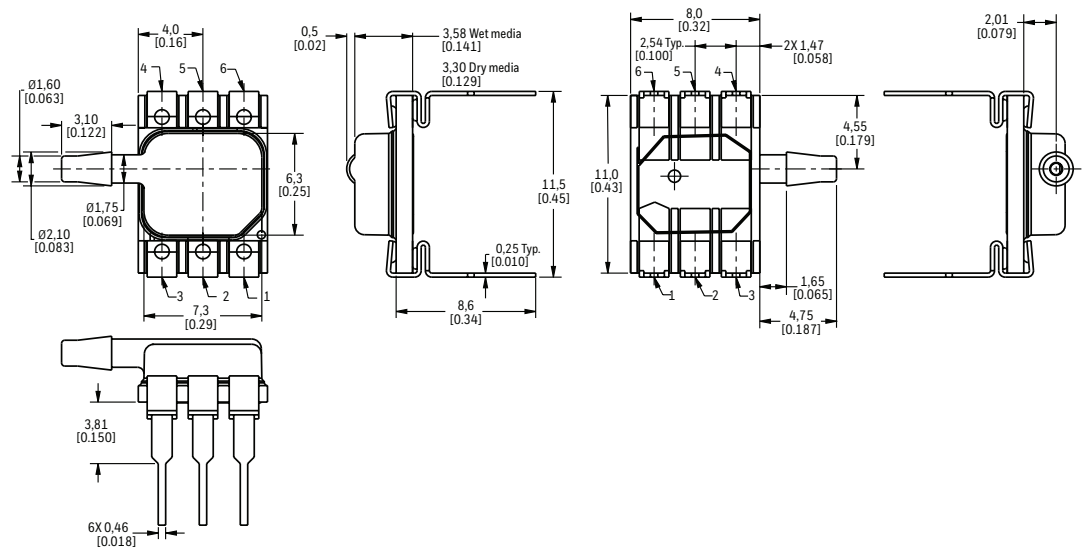
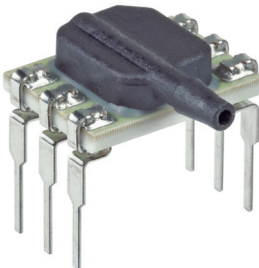

DIP RR: Dual radial barbed ports, same side

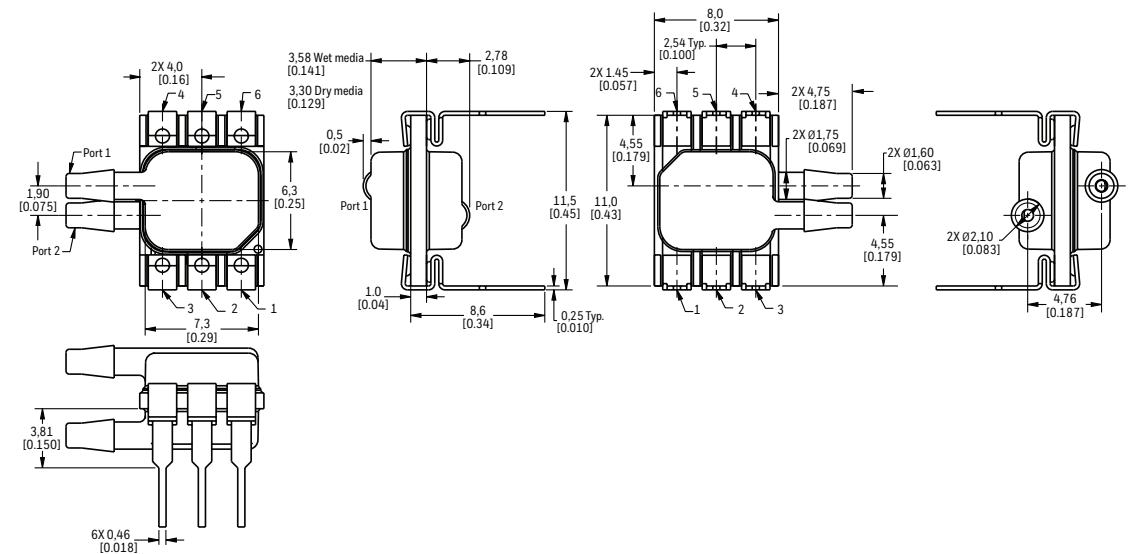
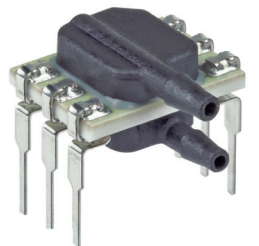

BASIC BOARD MOUNT PRESSURE SENSORS, ABP SERIES

FIGURE 6. SMT PACKAGE DIMENSIONAL DRAWINGS (FOR REFERENCE ONLY: MM [IN.])

SMT NN: No port



SMT AN: Single axial barbed port



SMT LN: Single axial barbless port

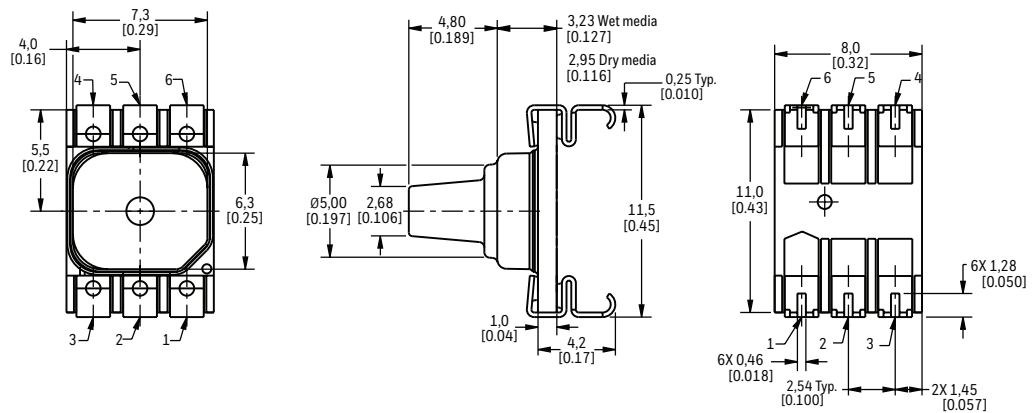

SMT JN: Single radial barbless port

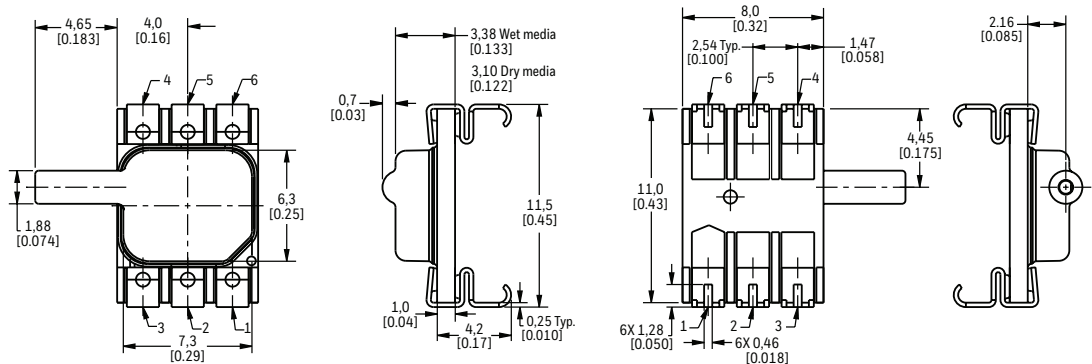

BASIC BOARD MOUNT PRESSURE SENSORS, ABP SERIES

FIGURE 6. SMT PACKAGE DIMENSIONAL DRAWINGS (CONTINUED)

SMT JJ: Dual radial barless ports, same side

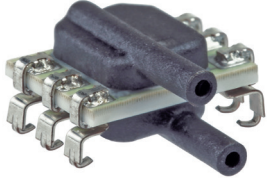

SMT RN: Single radial barbed port

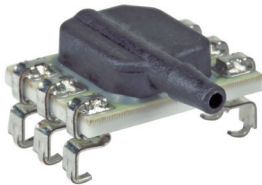

SMT RR: Dual radial barbed ports, both sides

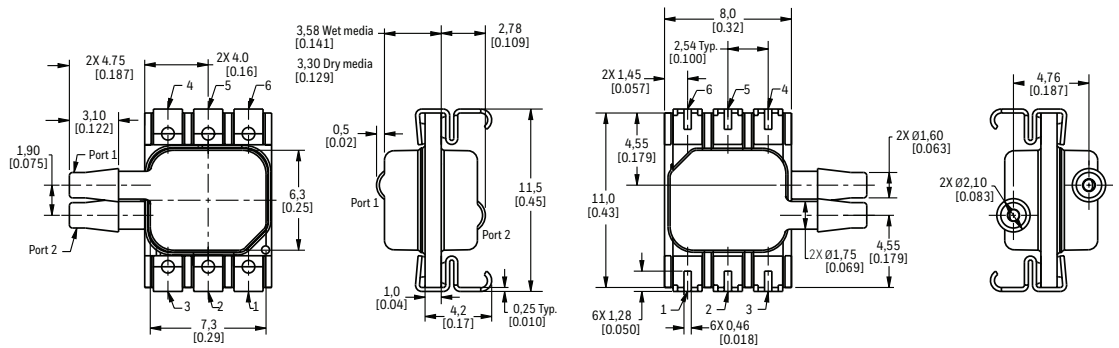
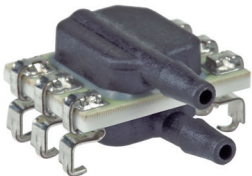

BASIC BOARD MOUNT PRESSURE SENSORS, ABP SERIES

FIGURE 7. LEADLESS SMT PACKAGE DIMENSIONAL DRAWINGS (FOR REFERENCE ONLY: MM [IN.]

Leadless SMT NN: No port

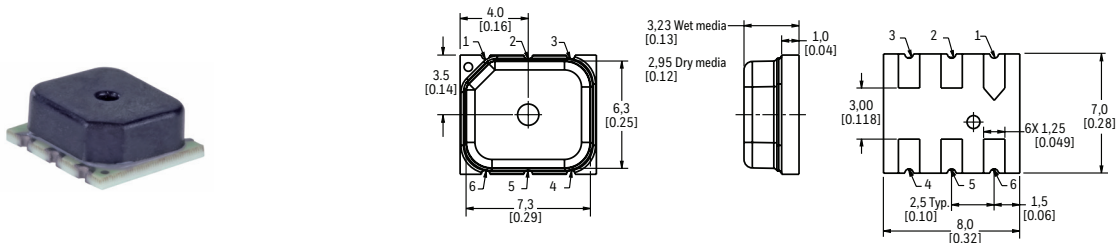

Leadless SMT AN: Single axial barbed port

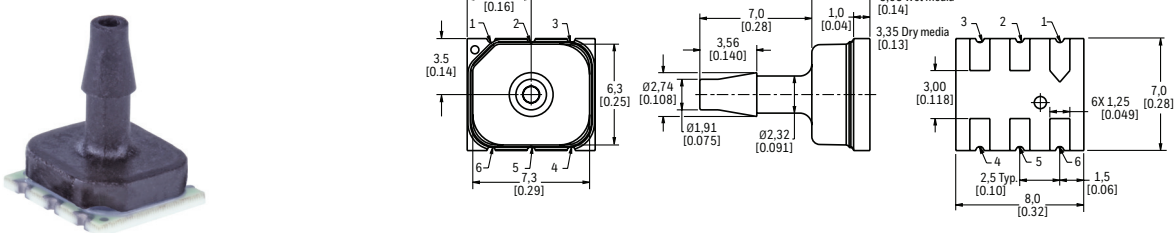

Leadless SMT LN: Single axial barbless port

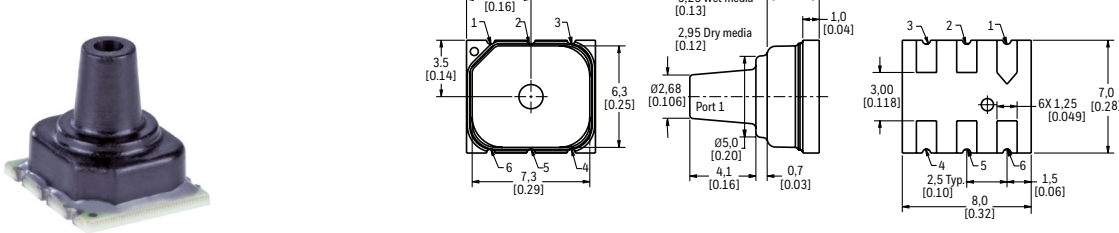
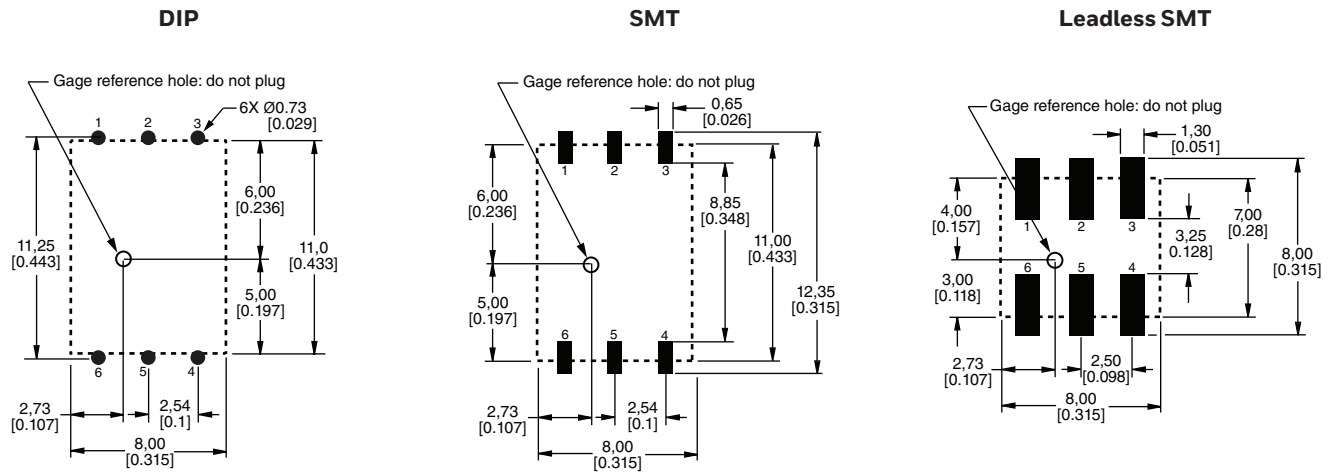

TABLE 8. PINOUTS

| OUTPUT TYPE | PIN 1 | PIN 2 | PIN 3 | PIN 4 | PIN 5 | PIN 6 |
|------------------|-------|---------------------|------------------|-------|-------|---------------------|
| I ² C | GND | V _{supply} | INT | NC | SDA | SCL |
| SPI | GND | V _{supply} | SS | NC | MISO | SCLK |
| analog | GND | NC | V _{out} | NC | NC | V _{supply} |

FIGURE 8. RECOMMENDED PCB LAYOUTS



ADDITIONAL MATERIALS

The following associated literature is available at sensing.honeywell.com:

- Product range guide
- Installation instructions
- Application note

WARRANTY/REMEDY

Honeywell warrants goods of its manufacture as being free of defective materials and faulty workmanship during the applicable warranty period. Honeywell's standard product warranty applies unless agreed to otherwise by Honeywell in writing; please refer to your order acknowledgment or consult your local sales office for specific warranty details. If warranted goods are returned to Honeywell during the period of coverage, Honeywell will repair or replace, at its option, without charge those items that Honeywell, in its sole discretion, finds defective.

The foregoing is buyer's sole remedy and is in lieu of all other warranties, expressed or implied, including those of merchantability and fitness for a particular purpose. In no event shall Honeywell be liable for consequential, special, or indirect damages.

While Honeywell may provide application assistance personally, through our literature and the Honeywell web site, it is buyer's sole responsibility to determine the suitability of the product in the application.

Specifications may change without notice. The information we supply is believed to be accurate and reliable as of this writing. However, Honeywell assumes no responsibility for its use.

FOR MORE INFORMATION

Honeywell Sensing and Internet of Things services its customers through a worldwide network of sales offices and distributors. For application assistance, current specifications, pricing or the nearest Authorized Distributor, visit sensing.honeywell.com or call:

| | |
|---------------|---------------------|
| USA/Canada | +1 302 613 4491 |
| Latin America | +1 305 805 8188 |
| Europe | +44 1344 238258 |
| Japan | +81 (0) 3-6730-7152 |
| Singapore | +65 6355 2828 |
| Greater China | +86 4006396841 |

Honeywell Sensing and Internet of Things

830 East Arapaho Road
Richardson, TX 75081
sensing.honeywell.com

WARNING PERSONAL INJURY

DO NOT USE these products as safety or emergency stop devices or in any other application where failure of the product could result in personal injury.

Failure to comply with these instructions could result in death or serious injury.

WARNING MISUSE OF DOCUMENTATION

- The information presented in this product sheet is for reference only. Do not use this document as a product installation guide.
- Complete installation, operation, and maintenance information is provided in the instructions supplied with each product.

Failure to comply with these instructions could result in death or serious injury.

X-ON Electronics

Largest Supplier of Electrical and Electronic Components

Click to view similar products for [Board Mount Pressure Sensors](#) category:

Click to view products by [Honeywell](#) manufacturer:

Other Similar products are found below :

[6407-249V-17343P](#) [6407-250V-09273P](#) [6407-250V-09343P](#) [80527-25.0H2-05](#) [80541-B00000150-01](#) [80541-B00000200-05](#) [80554-00700100-05](#) [80568-00300050-01](#) [93.631.4253.0](#) [93.731.4353.0](#) [93.932.4553.0](#) [136PC15A1](#) [142PC95AW71](#) [142PC05DW70](#) [15PSI-G-4V](#) [1805-01A-L0N-B](#) [26PCBKT](#) [26PCCFA6D26](#) [26PCCFS2G](#) [26PCCVA6D](#) [93.632.7353.0](#) [93.731.3653.0](#) [93.931.4853.0](#) [93.932.4853.0](#) [SDP510-500PA](#) [185PC30DH](#) [20INCH-G-MV-MINI](#) [26PCAFJ3G](#) [26PCCEP5G24](#) [26PCCFJ3G](#) [26PCDFA3G](#) [26PCJEU5G19](#) [30INCH-D1-MV-MINI](#) [ASCX15AN-90](#) [ASCX15AN/SZ76114](#) [4426-015G](#) [4525-DS5A030DP](#) [DCAL401DN](#) [DCAL401GN](#) [4515-DS5A020DP](#) [XZ202798SSC](#) [XZ203676HSC](#) [6407-249V-09273P](#) [6407-249V-09343P](#) [6407-249V-17273P](#) [6407-250V-17273P](#) [6407-250V-17343P](#) [81717-00000050-05](#) [81794-B00001200-01](#) [82681-B00000100-01](#)