

# Installation Instructions for CS Series Linear Current Sensor Holder Assemblies

PK 87914

## GENERAL INFORMATION

CS Series current sensor holder assemblies have a single linear output that will source current. The output voltage, which is ratiometric, varies in direct proportion to the supply voltage. (Refer to Catalog 20 for more information). These sensors will not be damaged by overcurrent in the sensed conductor.

## NORMAL MOUNTING

### Bottom mount version:

0.375 inch long 4-40 screw and a square nut (not provided) inserted in the housing.

### Side mount version:

0.250 inch long 6-32 screw and a square nut (not provided) inserted in the housing.

## SOLDERING INSTRUCTIONS

**Hand Soldering** - Use 60/40 rosin core solder, employing a 399°C (750°F) controlled temperature, 1/8" chisel tip soldering iron. To avoid delamination of the terminals from the ceramic, do not hold the iron on the terminals for more than four seconds. The temperature of the lead at the ceramic conductor interface must not exceed 250°C (482°F).

**Wave Soldering** - Use Loncoflux 106A35 or equivalent. Preheaters should be set for 95°C (200°F) on top (component side) of printed circuit board just prior to board entering wave. (This may have to be adjusted depending upon board thickness.) Solder temperature should be a maximum of 260°C (500°F), preferably 252°C to 260°C (485°F to 500°F). Set conveyor speed to approximately 4.5 feet per minute (1,37

meter/min.). Select a speed which gives full solder fillets and minimum of bridging and icicles. The printed circuit board requires rigid support during wave soldering.

## CLEANING

Proper cleaning fluids should be selected based on the type of contaminants to be removed. HONEYWELL recommends alcohols, chlorinated solvents, and fluorinated solvents.

## NOTICE

**Electrical**- Do not exceed maximum supply ratings. Do not reverse supply voltage polarity.

**Handling** -The terminals are fragile. Handle with care.

**Dielectric Isolation**- The toroidal cores are conductive. The user must provide the necessary dielectric isolation.

## MOUNTING DIMENSIONS (for reference only)

Figure 1

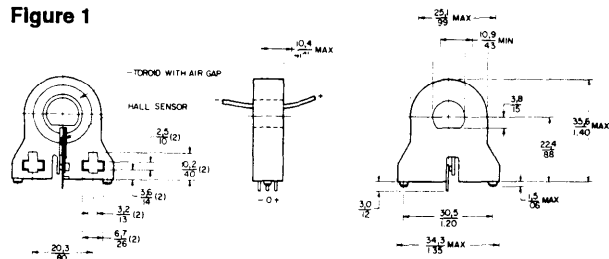

Figure 3

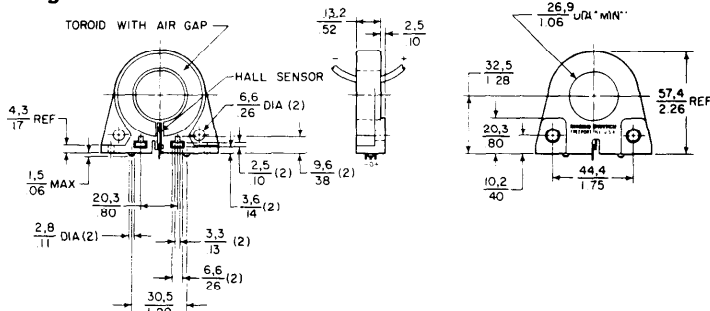

Figure 2

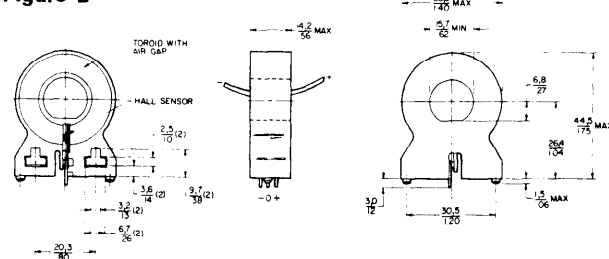
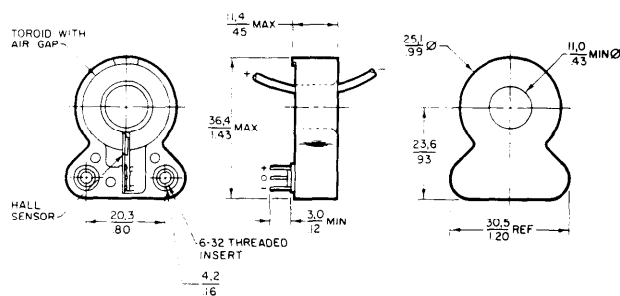

Figure 4



## WARRANTY/REMEDY

Seller warrants its products to be free from defects in design, material and workmanship under normal use and service. Seller will repair or replace without charge any such product it finds to be so defective on its return to Seller within 18 months after date of shipment by Seller. **The foregoing is in lieu of all other expressed or implied warranties (except of title), including those of merchantability and fitness for a particular purpose.** The foregoing is also purchaser's sole remedy and is in lieu of all other guarantees, obligations, or liabilities or any consequential,

incidental, or punitive damages attributable to negligence or strict liability, all by way of example.

For application assistance, current specifications or technical help, call toll free 800/537-6945.

While we provide assistance on HONEYWELL products, personally and through our literature, it is up to the customer to determine the suitability of the product in the application.

# CS Series Linear Current Sensor Holder Assemblies

PK 87914

## OPERATING CHARACTERISTICS

### BOTTOM MOUNT WITH 9SS (LOHET I) SENSOR

Catalog Listing	Core Gap (in.)	Mtg. Dim. Fig.	Supply Voltage (DC)	Supply Current (mA max.)	Sensed Current* (Amps-Peak)	Offset Voltage (V ± 10%)	Temp. Range °C	Offset Shift (%/°C)	Response Time (µS)
CSLA1CD	0.075	1	8 to 16	19	57	V <sub>cc</sub> /2	-25 to +85	±0.05	3
CSLA1CE	0.094	1	8 to 16	19	75	V <sub>cc</sub> /2	-25 to +85	±0.05	3
CSLA1DE	0.094	2	8 to 16	19	75	V <sub>cc</sub> /2	-25 to +85	±0.05	3
CSLA1CF	0.125	1	8 to 16	19	100	V <sub>cc</sub> /2	-25 to +85	±0.05	3
CSLA1DG	0.149	2	8 to 16	19	120	V <sub>cc</sub> /2	-25 to +85	±0.05	3
CSLA1CH	0.188	1	8 to 16	19	150	V <sub>cc</sub> /2	-25 to +85	±0.05	3
CSLA1DJ	0.276	2	8 to 16	19	225	V <sub>cc</sub> /2	-25 to +85	±0.05	3
CSLA1EJ	0.276	3	8 to 16	19	225	V <sub>cc</sub> /2	-25 to +85	±0.05	3
CSLA1DK	0.375	2	8 to 16	19	325	V <sub>cc</sub> /2	-25 to +85	±0.05	3
CSLA1EK	0.375	3	8 to 16	19	325	V <sub>cc</sub> /2	-25 to +85	±0.05	3
CSLA1EL	0.590	3	8 to 16	19	625	V <sub>cc</sub> /2	-25 to +85	±0.05	3

### BOTTOM MOUNT WITH SS9 (LOHET II) SENSOR

Catalog Listing	Core Gap (in.)	Mtg. Dim. Fig.	Supply Voltage (DC)	Supply Current (mA max.)	Sensed Current* (Amps-Peak)	Offset Voltage (V ± 2%)	Temp. Range °C	Offset Shift (%/°C)	Response Time (µS)
CSLA2CD	0.075	1	6 to 12	20	72	V <sub>cc</sub> /2	-25 to +85	±0.02	3
CSLA2CE	0.094	1	6 to 12	20	92	V <sub>cc</sub> /2	-25 to +85	±0.02	3
CSLA2DE	0.094	2	6 to 12	20	92	V <sub>cc</sub> /2	-25 to +85	±0.02	3
CSLA2CF	0.125	1	6 to 12	20	125	V <sub>cc</sub> /2	-25 to +85	±0.02	3
CSLA2DG	0.149	2	6 to 12	20	150	V <sub>cc</sub> /2	-25 to +85	±0.02	3
CSLA2DH	0.125	2	6 to 12	20	235	V <sub>cc</sub> /2	-25 to +85	±0.0125	3
CSLA2DJ	0.266	2	6 to 12	20	225	V <sub>cc</sub> /2	-25 to +85	±0.02	3
CSLA2EJ	0.160	3	6 to 12	20	310	V <sub>cc</sub> /2	-25 to +85	±0.0125	3
CSLA2DK	0.210	2	6 to 12	20	400	V <sub>cc</sub> /2	-25 to +85	±0.0125	3
CSLA2EL	0.276	3	6 to 12	20	550	V <sub>cc</sub> /2	-25 to +85	±0.0125	3
CSLA2EM	0.160	3	6 to 12	20	765	V <sub>cc</sub> /2	-25 to +85	±0.008	3
CSLA2EN	0.210	3	6 to 12	20	950	V <sub>cc</sub> /2	-25 to +85	±0.008	3

### SIDE MOUNT WITH 9SS (LOHET I) SENSOR

Catalog Listing	Core Gap (in.)	Mtg. Dim. Fig.	Supply Voltage (DC)	Supply Current (mA max.)	Sensed Current* (Amps-Peak)	Offset Voltage (V ± 10%)	Temp. Range °C	Offset Shift (%/°C)	Response Time (µS)
CSLA1GD	0.075	4	8 to 16	19	57	V <sub>cc</sub> /2	-25 to +85	±0.05	3
CSLA1GE	0.094	4	8 to 16	19	75	V <sub>cc</sub> /2	-25 to +85	±0.05	3
CSLA1GF	0.125	4	8 to 16	19	100	V <sub>cc</sub> /2	-25 to +85	±0.05	3

### SIDE MOUNT WITH SS9 (LOHET II) SENSOR

Catalog Listing	Core Gap (in.)	Mtg. Dim. Fig.	Supply Voltage (DC)	Supply Current (mA max.)	Sensed Current* (Amps-Peak)	Offset Voltage (V ± 2%)	Temp. Range °C	Offset Shift (%/°C)	Response Time (µS)
CSLA2GD	0.075	4	6 to 12	20	72	V <sub>cc</sub> /2	-25 to +85	±0.02	8
CSLA2GE	0.094	4	6 to 12	20	92	V <sub>cc</sub> /2	-25 to +85	±0.02	8
CSLA2GF	0.125	4	6 to 12	20	125	V <sub>cc</sub> /2	-25 to +85	±0.02	8
CSLA2GG	0.149	4	6 to 12	20	150	V <sub>cc</sub> /2	-25 to +85	±0.02	8

**NOTE:** When monitoring purely AC current with zero DC component, a capacitor can be inserted in series with the output of the current sensor. The capacitor will block out the effect of the temperature variation of the offset voltage which increases the accuracy of the device.

## Honeywell Sensing & Control

Helping you control your world

## X-ON Electronics

Largest Supplier of Electrical and Electronic Components

*Click to view similar products for [Board Mount Current Sensors](#) category:*

*Click to view products by [Honeywell](#) manufacturer:*

Other Similar products are found below :

[CSDD1FR](#) [CSLA2ELI](#) [CSNP661-007](#) [SCL15 10006](#) [ACS723LLCTR-05AB-T](#) [L18P003S05](#) [T60404-B4658-X030](#) [LA02P021S03](#)  
[LA01M041S05](#) [LA03P054S05](#) [CSNE151-003](#) [L08P150D15IPV](#) [L18P050D15-OP](#) [SIC830AED-T1-GE3](#) [CT-05](#) [CT-07-100](#) [CT-07-50](#) [MR-1](#)  
[MR-1-P5](#) [T60404-N4646-X662](#) [T60404-N4646-X664](#) [DRV421RTJT](#) [CSNR161005](#) [T60404-N4646-X651](#) [MR-3](#) [MR-2](#) [MR-4](#) [CT-06-100](#)  
[CT-06-50](#) [T60404-N4646-X410](#) [T60404-N4646-X663](#) [CT-06-75](#) [CSDA1BA](#) [CSDA1BA-S](#) [CSDC1DA](#) [CSDD1EC](#) [CSLA1DE](#) [CSLA1DG](#)  
[CSLA1DK](#) [CSLA1EL](#) [CSLA1GE](#) [CSLA1GF](#) [CSLA2CDI](#) [CSLA2DE](#) [CSLA2DG](#) [CSLA2DH](#) [CSLA2DJ](#) [CSLA2DJI](#) [CSLA2EL](#) [CSLA2EM](#)