

CSSV1500 SERIES

006007
Issue 3

Current Sensors Designed to Meet ASIL C Requirements

DESCRIPTION

The CSSV1500 Series Current Sensors are based on Honeywell's advanced multi-sensing scheme, a single power supply and an integrated CAN bus output. They are calibrated and temperature compensated using multi-point temperature characterization. This Honeywell's patented digital compensation technology enables a high degree of accuracy throughout the sensing range up to ± 1500 A. The CSSV1500 Series is designed to meet Automotive Safety Integrity Level C (ASIL C) requirements for safety critical applications. These sensors have two independent sensing and data processing circuits for current sensing. The two processed data are checked for confidence. If they are within the set threshold range, the current data is outputted. If the threshold is exceeded, an alarm message is sent.

DIAGNOSTIC FUNCTIONALITY

The CAN output of the CSSV1500 Series offers fault detection and communication capability. Also, the digital CAN communication is nearly immune to electrical interference. Examples of sensor and host system faults include:

- Sensor fault
- Supply voltage over range
- Supply voltage under range

CUSTOMIZATION

The CSSV1500 Series may be customized to better meet application needs. Solutions may be tailored to exact specifications for improved time to market, lower total system costs and enhanced reliability.

DIFFERENTIATION

- **Accuracy:** Multi-point temperature characterization and calibration for improved accuracy over the temperature range
- **Magnetic immunity:** Sensing configuration and optimized magnetic circuit allow for enhanced performance in diverse magnetic environments
- **ASIL-C Compliance:** ASIL C for increased reliability in safety-critical applications

VALUE TO CUSTOMERS

- **Accurate:** Designed to enable precise battery state measurement for improved user experience
- **Ease of use:** Magnetic immunity allows for easy integration into different magnetic environments
- **Easy system integration:** CAN communication is transmitted using international road vehicle standard ISO 11898. CAN 2.0A is the default protocol

APPLICATIONS

- Current measurement for battery management systems in electrified vehicles (EV, HEV, PHEV, BEV)
- Current leakage detection and fault isolation in charging systems
- Current measurement in energy storage systems
- Fault detection in heavy industrial equipment



FEATURES

- Higher accuracy, lower temperature drift
- Enhanced EMC (Electromagnetic Compatibility) performance
- Designed to meet automotive Safety Integrity Level C (ASIL C) for the functional safety of road vehicle applications
- Reliable and stable CAN bus output
- Easy installation and software interface provide system integration convenience
- CE certification; REACH and RoHS compliant

PORTFOLIO

Honeywell offers a variety of current sensors for potential use in many applications. To view the entire product portfolio, [click here](#).

Honeywell

CSSV1500 SERIES CURRENT SENSORS

TABLE 1. ABSOLUTE MAXIMUM RATINGS (not operating)

Characteristic	Symbol	Unit	Parameter	Condition
Load dump over voltage	V_S	V	35	400 ms
Over voltage	V_S	V	24	10 min
		V	20	continuous
Reverse polarity	V_S	V	-24	10 min.
Supply voltage: minimum	V_S	V	6	continuous
maximum	V_S	V	18	continuous
CAN operation: supply voltage under range alarm, no measurement	V_S	V	5.5 to 5.9	CAN continuous
supply voltage over range alarm, no measurement	V_S	V	18.5 to 24	CAN continuous
Insulation resistance	R_{IS}	M Ω	2000	500 V at 1 min.
Creepage distance	d_{CP}	mm	10	—
Clearance	d_{CI}	mm	10	—
RMS voltage for ac isolation voltage	—	KV	5	50 Hz, 1 min.
Voltage for dc isolation voltage	—	KV	5	1 min.

TABLE 2. OPERATING SPECIFICATIONS IN NOMINAL RANGE (I_{PN})

Characteristic	Symbol	Unit	Specification			Condition
			Min.	Typ.	Max.	
Primary current, nominal measuring range (dc)	I_{PN}	A	-1500	—	1500	—
Supply voltage	V_S	V	6	12	18	—
Supply voltage hysteresis: maximum	V_{UP}	V	—	18.5	—	when V_C increases
	V_{UP}	V	—	18.0	—	when V_C decreases
minimum	V_{LOW}	V	—	6.4	—	when V_C increases
	V_{LOW}	V	—	5.9	—	when V_C decreases
Current consumption	I_C	mA	40	—	200	$V_S = 12$ V, $T = 25^\circ\text{C}$
Ambient operating temperature	T_A	$^\circ\text{C}$ [$^\circ\text{F}$]	-40 [-40]	—	85 [185]	temperature range with accuracy guaranteed
High precision channel offset at $I_p = 0$ A	I_{OS}	A	±0.1			$T = -40^\circ\text{C}$ to 85°C , $V_S = 9$ V to 16 V, ±3 sigma
High precision channel total accuracy: high at $I_p = 0$ A to 20 A	I_{OS}	A	-0.1	—	+0.1	$T = -40^\circ\text{C}$ to 85°C , $V_S = 9$ V to 16 V, ±3 sigma
high at 20 A < $I_p \leq 1500$ A	X_G	—	—	±0.5% of I_p	—	
Redundancy channel total accuracy: low at $I_p = 0$ A to 300 A	I_{OS}	A	-15	—	+15	$T = -40^\circ\text{C}$ to 85°C , $V_S = 9$ V to 16 V, ±3 sigma
low at $I_p = 300$ A to 1500 A	X_G	—	—	±5% of I_p	—	

CSSV1500 SERIES CURRENT SENSORS

TABLE 3. MECHANICAL SPECIFICATIONS

Characteristic	Parameter
Housing material	PA66+GF25 (UL 94V - 0)
Mounting screws	M5, torque = 3,5 N m max. The installation bracket should have a flatness tolerance of $\leq 0,2$ mm. The size tolerances of the installation bracket and nut, as well as the use of installation tools and fixtures, have an impact on the maximum installation torque of the product. If there are any relevant design or process changes, it is advisable to implement them after verification.
Mating electrical connector	TE MPN 1473672-1

TABLE 4. CERTIFICATIONS

Characteristic	Parameter
Automotive Safety Integrity Level	ASIL C
Pollution degree	PD2

Figure 1. Error vs. I_p

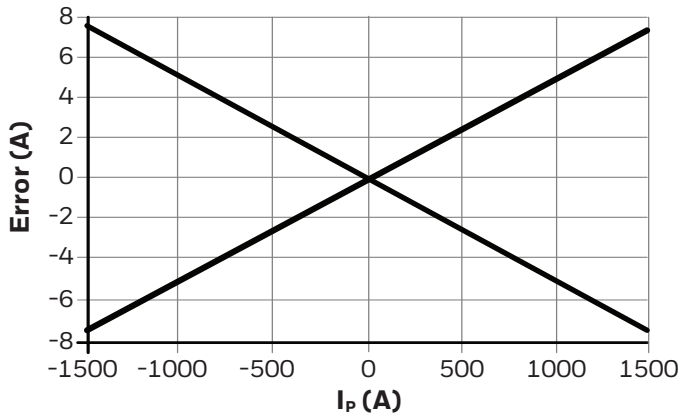

CSSV1500 SERIES CURRENT SENSORS

TABLE 5. ORDER GUIDE

Catalog Listing	Description
CSSV1500N-154	CSSV1500N Series ASIL C current sensors, 1500 A, through-hole mounting with stainless steel bushing, 500 k baud rate, 3C4 CAN ID
CSSV1500N-155	CSSV1500N Series ASIL C current sensors, 1500 A, through-hole mounting with stainless steel bushing, 500 k baud rate, 3C5 CAN ID
CSSV1500N-156	CSSV1500N Series ASIL C current sensors, 1500 A, through-hole mounting with stainless steel bushing, 500 k baud rate, 3C6 CAN ID
CSSV1500N-154R	CSSV1500N Series ASIL C current sensors, 1500 A, through-hole mounting with stainless steel bushing, 500 k baud rate, 3C4 CAN ID, reverse current direction
CSSV1500N-155R	CSSV1500N Series ASIL C current sensors, 1500 A, through-hole mounting with stainless steel bushing, 500 k baud rate, 3C5 CAN ID, reverse current direction
CSSV1500N-156R	CSSV1500N Series ASIL C current sensors, 1500 A, through-hole mounting with stainless steel bushing, 500 k baud rate, 3C6 CAN ID, reverse current direction

Figure 2. Nomenclature

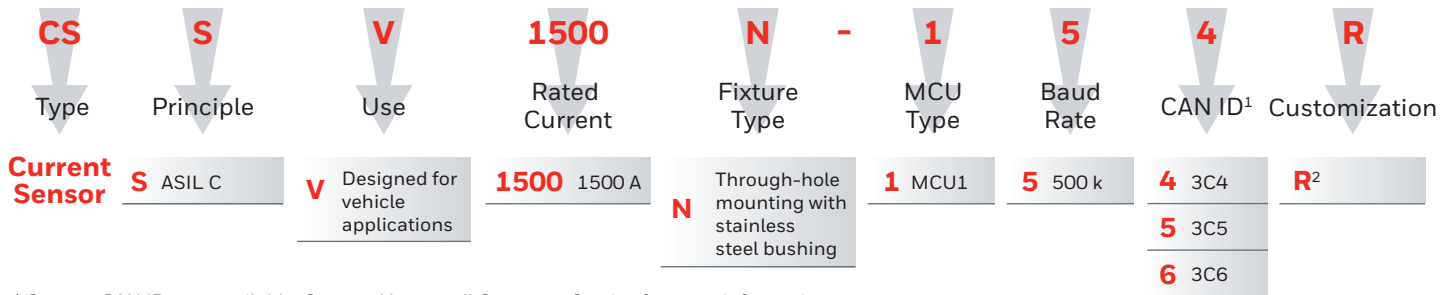

¹ Custom CAN IDs are available. Contact Honeywell Customer Service for more information.

² Customization selection "R" indicates reverse current direction.

CSSV1500 SERIES CURRENT SENSORS

TABLE 6. CAN BUS ELECTRICAL CHARACTERISTICS

Characteristic	Parameter
Speed	See Figure 2
Protocol	version 2.0A
Oscillator tolerance	0.3125%
Byte order	big endian (Motorola)

TABLE 7. CAN FRAME LAYOUT

Byte	SequenceCounterIP			Error Information			StatusOutOf RangeIndication	StatusCurrent ValueIndication
Standard CAN Frame								
0	7	6	5	4	3	2	1	0
High Precision Current Value								
1	15	14	13	12	11	10	9	8
2	23	22	21	20	19	18	17	16
3	31	30	29	28	27	26	25	24
Low Precision Current Value								
4	39	38	37	36	35	34	33	32
5	47	46	45	44	43	42	41	40
Software Build								
6	55	54	53	52	51	50	49	48
CRC_IP								
7	63	62	61	60	59	58	57	56

TABLE 8. SIGNAL DESCRIPTION

Signal Name	Description
SequenceCounterIP	Initial value is 0, plus 1 every frame. Reset to 0 when the counter reaches 14.
ErrorInformation	01: Power in Under Voltage, 10: Power in Over Voltage, 11: Internal Error, 10 state, Current Value Output 0xFFFFFFFF/0xFFFF 11 state, Output Current value
StatusOutOfRange	0: Normal, 1: Out of Measure Range
StatusCurrentValueInvalid	0: Current Value is valid, 1: Current Value is invalid
High Precision Current Value	Unsigned number 24 bits, Unit: mA (offset 0x800000) When out of range occurs, becomes 0xFFFFFFFF, Ip_oc = 1550 A
	$-1500 \leq I_p \leq +1500$ signal = I_p accuracy = Spec
	$-I_{p_oc} \leq I_p < -1500$ signal = I_p accuracy = $\pm 2\%$ (for reference)
	$+1500 < I_p \leq I_{p_oc}$ signal = I_p accuracy = $\pm 2\%$ (for reference)
	$I_p < -I_{p_oc}$ signal = 0xFFFFFFFF accuracy = NA
$I_p > I_{p_oc}$ signal = 0xFFFFFFFF accuracy = NA	
Low Precision Current Value	Unsigned number 16 bits, Unit: A (offset 0x8000) When out of range occurs, becomes 0xFFFF, Ip_oc = 1550 A
	$-1500 \leq I_p \leq +1500$ signal = I_p accuracy = $\pm 5\%$
	$-I_{p_oc} \leq I_p < -1500$ signal = I_p accuracy = $\pm 10\%$ (for reference)
	$+1500 < I_p \leq I_{p_oc}$ signal = I_p accuracy = $\pm 10\%$ (for reference)
	$I_p < -I_{p_oc}$ signal = 0xFFFF accuracy = NA
$I_p > I_{p_oc}$ signal = 0xFFFF accuracy = NA	
Software Build	Software version
CRC_IP	8 bit SAE J1850 CRC/AUTOSAR profile 1 DataId = Same as CAN ID; DataIdMode = E2E_PO1_DATAID_BOTH

CSSV1500 SERIES CURRENT SENSORS

Figure 3. Dimensional Drawings (For reference only: mm/IN)

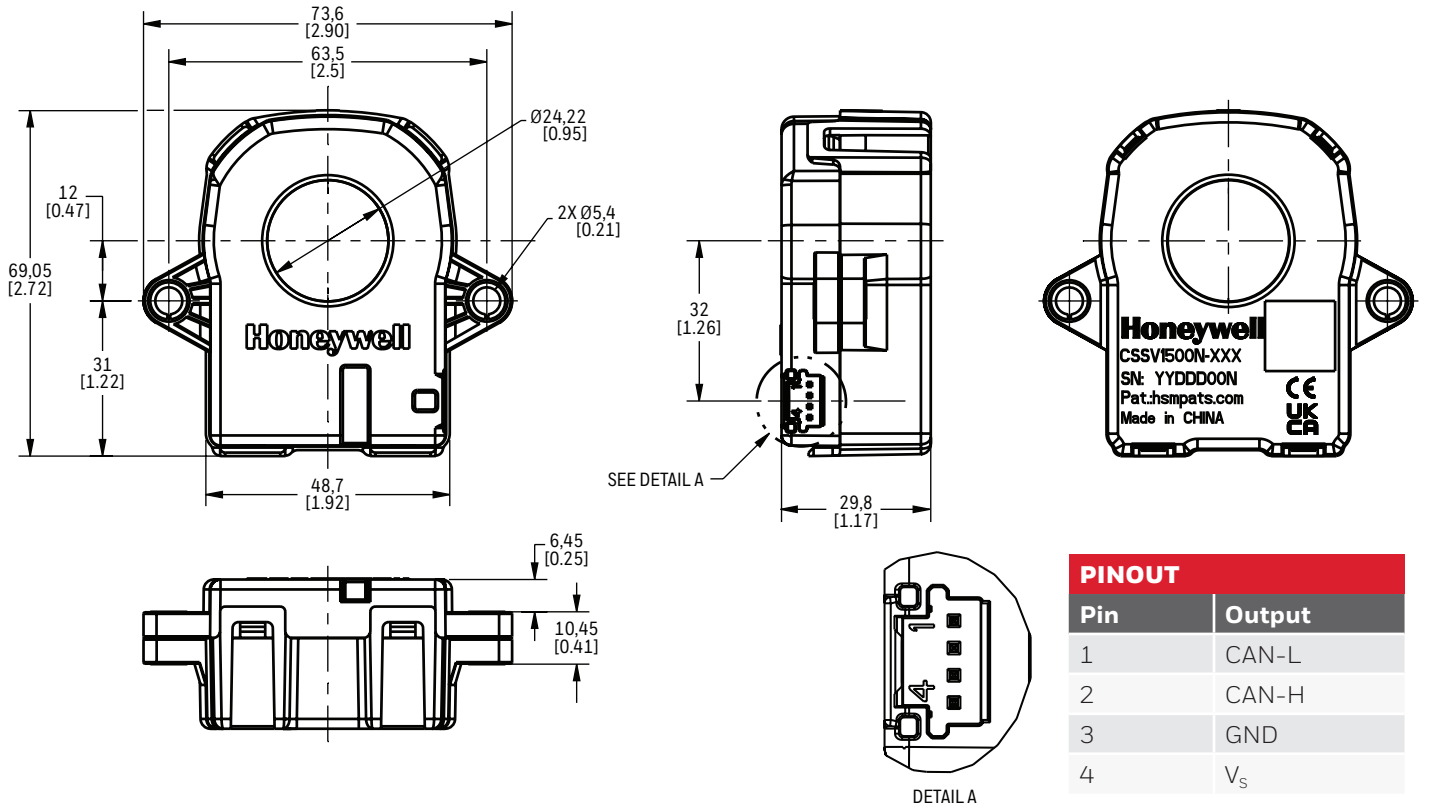

PINOUT	
Pin	Output
1	CAN-L
2	CAN-H
3	GND
4	V _s

Figure 4. Part Marking Details

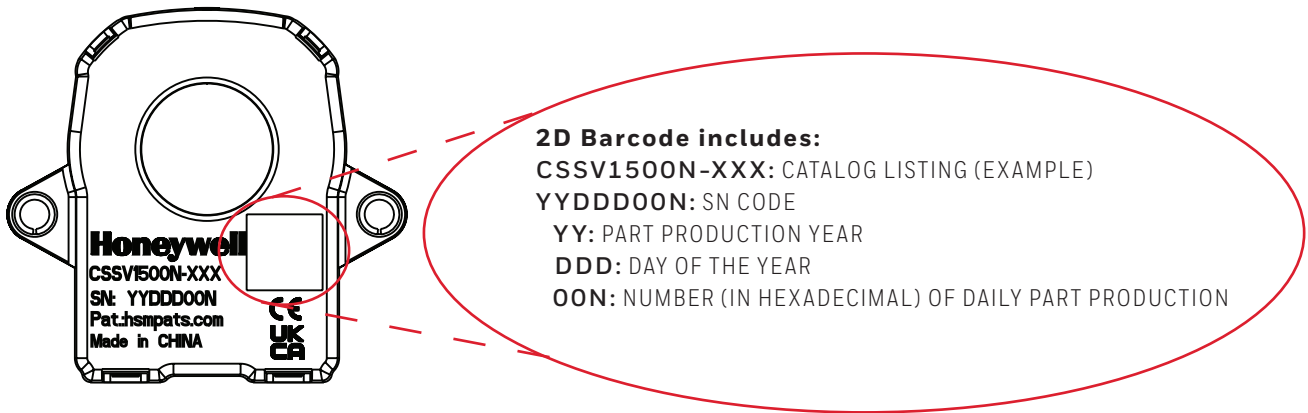
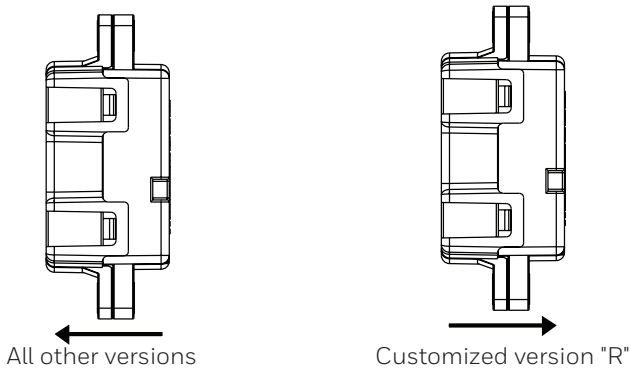

Figure 5. I_p Positive Primary Current Direction (Polarity)



CSSV1500 SERIES CURRENT SENSORS

TABLE 9. EMC TEST SPECIFICATIONS

Test Name	Standard	Procedure
CISPR 25 Conducted RF Emissions - Voltage	CISPR25	According to CISPR 25:2008 Commission Form of Testing
CISPR 25 Conducted RF Emissions - Current	CISPR25	According to CISPR 25:2008 Commission Form of Testing
CISPR 25 Radiated Emissions - ALSE Method	CISPR25	According to CISPR 25:2008 Commission Form of Testing
Transient Conduction Emission	ISO 7637-2	According to ISO 7637-2
Low Frequency Magnetic Field Emission	SAE J551-5	According to SAE J551-5
Bulk Current Injection (BCI) Test	ISO 11452-4	According to ISO 11452-4
Rf Anti-Interference - ALSE Method	ISO 11452-2	According to ISO 11452-2
Transient Disturbances Conducted along Supply Lines	ISO 7637-2	According to ISO 7637-2
Transient Disturbances Conducted along I/O or Sensor Lines	ISO 7637-3	According to ISO 7637-3
Low Frequency Field Interference	ISO 11452-8	According to ISO 11452-8
Electrostatic Discharge	ISO 10605	Unpowered direct contact discharge: ±15 kV Unpowered air discharge: ±15 kV Powered-up direct contact discharge: ±8 kV Powered-up air discharge: ±15 kV
Portable Transmitter	ISO 11452-9	According to ISO 11452-9
Radio Frequency Electromagnetic Field	IEC 61000-4-3	10 V/m (80 MHz to 1 GHz), 3 V/m (1.4 GHz to 2 GHz), 1 V/m (2.0 GHz to 2.7 GHz)
Fast Transients Bursts Susceptibility Test	IEC 61000-4-4	2 kV Power port, 2 kV CAN signal and control port
Radio Frequency Continuous Conducted	IEC 61000-4-6	0.15 MHz to 80 MHz, 3 V 80% AM (1 kHz)
Radio Frequency Magnetic Field	IEC 61000-4-8	30 A/M
Radiated Disturbance (3M semi-anechoic chamber)	CISPR-11	Group 1, Class A

CSSV1500 SERIES CURRENT SENSORS

TABLE 10. ENVIRONMENTAL TEST SPECIFICATIONS

Test Name	Standard	Procedure
Low Temperature Storage	ISO16750-4	48 hr, 85°C power off. Performance test before and after test at 25°C and V _S nom.
High Temperature Storage	ISO16750-4	48 hr, -40°C power off. Performance test before and after test at 25°C and V _S nom.
Thermal Cycle Test	ISO16750-4	120 cycles: one cycle contains -40°C (120 min soak) and 85°C (120 min soak). Transition time = 120 min. Performance test before and after test at 25°C and V _S nom.
High Temperature and Humidity Endurance	ISO16750-4	1000 hr, 85°C, 85% humidity, power on. Performance after test, from -40°C to 85°C, notify XG ≤1 %
Vibration	IEC60068-2-64	5 Hz to 2000 Hz, 20 hr/axis, three axes with -40°C/85°C temperature cycle during test. Product power on. Performance test before and after test at 25°C and V _S nom.
Mechanical Shock	ISO16750-3	500 m/s, 2,20 each direction (60 total), half sine pulse. Product power on. Performance test before and after test at 25°C and V _S nom.
Package Drop	ISTA-1A or GB/T 4857.5	With final packaging, drop in direction at one corner, three edge, four face > total nine drops, one m on concrete floor. Performance test before and after test at 25°C and V _S nom.
Handling Drop	ISO 16750-3	First fall of each DUT at a different dimensional axis. Second fall with the given DUT at the same dimensional axis but on the opposite side of the housing, from 1 m on concrete floor. Performance test before and after test at 25°C and V _S nom.
Waterproof and Dust (and other Solid Intrusion)	ISO20653	IP category: 40

CSSV1500 SERIES CURRENT SENSORS

TABLE 11. ELECTRICAL TEST SPECIFICATIONS¹

Test Name	Standard	Procedure
Long Time Overvoltage Test	ISO 16750-2	Power supply at 18 V for 60 min.
Superimposed Alternating Voltage	ISO 16750-2	Test voltage U_c max 16 V for 12 V systems; ac voltage (sinusoidal): Severity 2, UPP = 4 V
Slow Decrease Fast Increase of Supply Voltage	ISO 16750-2-4.5	According to ISO 16750-2-4.5 testing standard and Fig
Reset Behavior at Voltage Drop	ISO16750-2-4.6.2.2	See Fig. 6
Transient Overvoltage Test	ISO16750-2	Power supply at 24 V for 10 min.
Momentary Drop in Supply Voltage	ISO 16750-2-4.6.1	U_c min to 4.5 V. See Fig. 4
Load Dump	ISO 16750-2-4.6.4	Pulse described in Table 6. See Fig. 9
Reverse Voltage Test	ISO16750-2-4.7	Power supply at -24 V for 10 min.
Single Line Open Circuit Tests	ISO16750-2-4.9	Connect sensor to 12 V power supply and power on the sensor. Disconnect U_s , GND, CAN-H, and CAN-L in sequence. Each open circuit time: 60 ± 1 s
Connector Open Circuit Tests	ISO16750-2	Connect sensor to 12 V power supply and power on the sensor. Disconnect connector. Each open circuit time: 10 ± 1 s
Insulation Resistance Test	ISO 16750-2-4.12	500 Vdc for 60 s; Resistance criteria: >500 MOhm
dc and ac Voltage Insulation Test	—	Test Voltage: 5000 Vdc and ac. Frequency: dc and 50~60 Hz. Test Duration: 60 s

¹ See the applicable standard for all table and figure references.

NOTICE PRELIMINARY DOCUMENTATION

The information contained in this document is preliminary and for reference only. Preliminary means that the product described has not been or is currently being formally tested. Specifications are subject to change without notice. Reliance on the information contained herein is at the reader's own risk.

For more information

Honeywell Sensing & Safety Technologies services its customers through a worldwide network of sales offices and distributors. For application assistance, current specifications, pricing or the nearest Authorized Distributor, visit our [website](#) or call:

USA/Canada	+1 302 613 4491
Latin America	+1 305 805 8188
Europe	+44 1344 238258
Japan	+81 (0) 3-6730-7152
Singapore	+65 6355 2828
Greater China	+86 4006396841

Honeywell Sensing & Safety Technologies

830 East Arapaho Road
Richardson, TX 75081
www.honeywell.com

WARRANTY/REMEDY

Honeywell warrants goods of its manufacture as being free of defective materials and faulty workmanship during the applicable warranty period. Honeywell's standard product warranty applies unless agreed to otherwise by Honeywell in writing; please refer to your order acknowledgment or consult your local sales office for specific warranty details. If warranted goods are returned to Honeywell during the period of coverage, Honeywell will repair or replace, at its option, without charge those items that Honeywell, in its sole discretion, finds defective.

The foregoing is buyer's sole remedy and is in lieu of all other warranties, expressed or implied, including those of merchantability and fitness for a particular purpose. In no event shall Honeywell be liable for consequential, special, or indirect damages.

While Honeywell may provide application assistance personally, through our literature and the Honeywell web site, it is buyer's sole responsibility to determine the suitability of the product in the application.

Specifications may change without notice. The information we supply is believed to be accurate and reliable as of this writing. However, Honeywell assumes no responsibility for its use.

WARNING PERSONAL INJURY

DO NOT USE these products as safety or emergency stop devices or in any other application where failure of the product could result in personal injury.

Failure to comply with these instructions could result in death or serious injury.

WARNING MISUSE OF DOCUMENTATION

- The information presented in this product sheet is for reference only. Do not use this document as a product installation guide.
- Complete installation, operation, and maintenance information is provided in the instructions supplied with each product.

Failure to comply with these instructions could result in death or serious injury.

X-ON Electronics

Largest Supplier of Electrical and Electronic Components

Click to view similar products for [Industrial Current Sensors](#) category:

Click to view products by [Honeywell](#) manufacturer:

Other Similar products are found below :

[CSNS181](#) [L05Z800S15](#) [CSNS300M-500](#) [LA200-P](#) [ACS711ELCTR-25AB-T](#) [ACS724LLCTR-10AB-T](#) [ACS770LCB-050U-PFF-T](#)
[LCS10T12](#) [20320500101](#) [20310508201](#) [CCT354571-300-24-00](#) [LCSC10T12](#) [2813473](#) [CCT272440-80-10-02](#) [S21S180D15JN](#) [T60404-](#)
[N4644-X051](#) [L31S300S05FS](#) [ISB-300-A-802](#) [ISB-100-A-802](#) [LPMG12](#) [ECS41BD](#) [SAO-SU1N](#) [SAO-S5N](#) [ECS41AC](#) [ECS40BC](#)
[ACS712ELCTR-20A-T](#) [BB-JC10F50-V](#) [BCY2-100IOV2M](#) [BCY2-200IOV2M](#) [BCY2-75IOV2M](#) [BL1Y2-150IOV2L](#) [BSL-800IOV2M](#)
[BSY2-150/4IOV2](#) [CTV1X60A333MV](#) [ROG4K1002M6003X](#) [CHI612TB03125](#) [CHI612FB03125](#) [CC6900SO-10A](#) [CC6900SO-20A](#)
[CC6900SO-30A](#) [CC6900SO-5A](#) [CC6901SO-20A](#) [CC6902SO-10A](#) [CC6902SO-20A](#) [CC6902SO-30A](#) [CSNS300F-001](#) [CC6903SO-30A](#)
[CC6904SO-20A](#) [20310300101](#) [20310500101](#)