

Installation Instructions for the GKR/GKL Series Solenoid Key Operated Safety Interlock Switch



⚠️ WARNING

IMPROPER INSTALLATION

- Consult with local safety agencies and their requirements when designing a machine-control link, interface, and all control elements that affect safety.
- Strictly adhere to all installation instructions.

Failure to comply with these instructions could result in death or serious injury.

GENERAL INFORMATION

The MICRO SWITCH GK Solenoid Key Operated Safety Interlock Switch is designed to lock protective guards that prevent access to hazardous motion so that dangerous machine operations can only take place if the protective guard is closed and locked. Likewise, the protective guard cannot be opened if hazardous motion is present.

The control system must be designed so that hazardous motion can only take place when the protective guard is locked via the GKR/GKL Series Solenoid Key Operated Safety Interlock Switch. This control system design must ensure the guard locking device releases only when the dangerous conditions no longer exist (Figure 1).

The guard locking device can be specified as either Mechanical Lock or Solenoid Lock (see order guide).

Mechanical Lock occurs by internal spring force when the protective guard is closed and the key is inserted. Applying voltage to the solenoid unlocks the protective guard. When power failure occurs, the protective guard can be unlocked by actuating the auxiliary release.

Solenoid Lock occurs by applying voltage to the solenoid after the protective guard is closed and the key is inserted. Removing voltage to the solenoid unlocks the protective guard.

Figure 1. Example Safety-Related Control Circuit

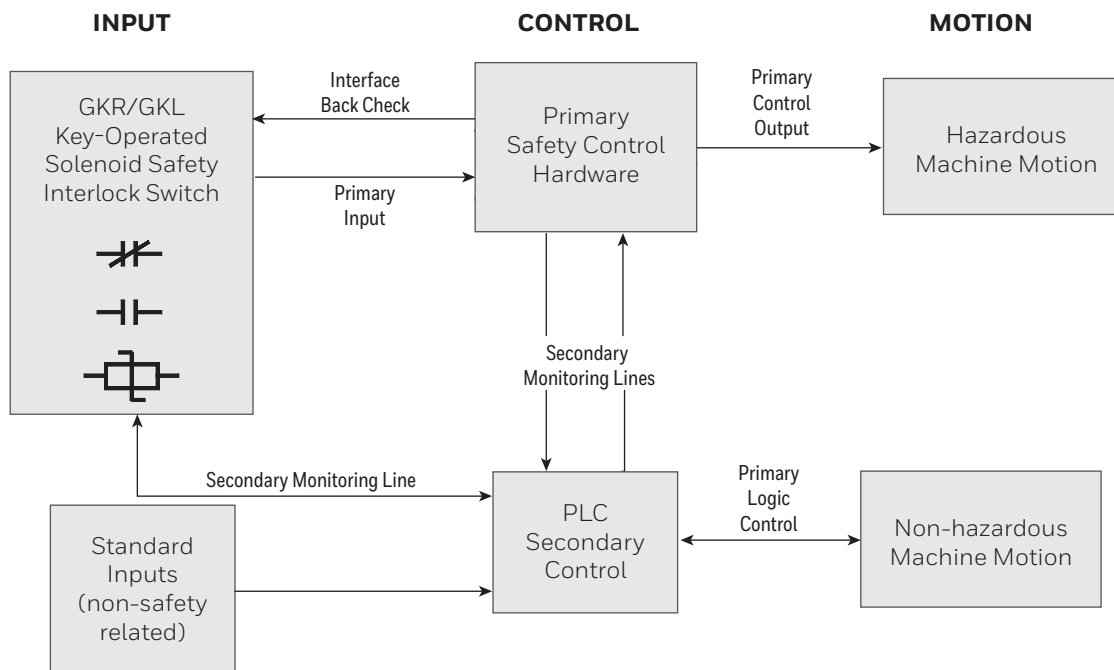

SAFETY ANALYSIS TECHNIQUES

1. Conduct Hazard Analysis and Risk Assessment. Refer to:

- OSHA Title 29, ANSI Standards
- European Norm EN 1050, Safety of Machines Risk Assessment

2. Review Requirements and Safety-Related Parts of the Control System

- ANSI B11.19-1990 – Safeguarding When Referenced by the Other B11 Machine Tool Safety Standards
- ANSI B11.20 – System Energy Stopping
- European Norms:
 - EN954-1: Safety Related Parts of the Control Systems
 - EN60204-1: Electrical Equipment of Machines.
 - prEN1088: Interlocking Devices With and Without Guard Locking
- Any other appropriate industry safety standards

PERFORM INSTALLATION AS FOLLOWS:

1. Assemble Switch Head (applies to Head Options “E” and “K” only)

NOTICE

The TORX® screws must be used on this head option to prevent voiding the warranty.

Head options “E” and “K” are shipped unattached and may be indexed in 90° increments (Figure 2).

- Remove cover
- Properly seat:
 - “O” ring (1) in its seal groove
 - Plunger (2)
- Determine required key entry location
- Place head on housing, moving metal spacer over enough to allow plunger to fall into position (contacts basic switch)
- Securely fasten operating head to switch housing with the four TORX® screws provided. Torque screws to 1,36 N-m to 1,80 N-m [12 in-lb to 16 in-lb]
- Replace cover

Figure 2. Head Options “E” and “K”

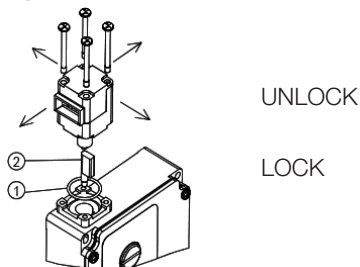

Mount, Wire and Seal Switch

Step 1 - Ensure you have the following:

- Switch and key
- Wire (use 90 °C wire when ambient temperature is over 75 °C):
 - Stranded: 0,75 mm² to 2,5 mm², 18-14 AWG, or
 - Solid: 0,75 mm² to 1,5 mm², 18-16 AWG
- M5 or #10 screws

Step 2 - Mount switch and key

WARNING IMPROPER INSTALLATION

- Ensure key travels to the minimum insertion dimension to ensure switch contact transfer (Figure 4).
- Ensure key travels to maximum extraction distance to ensure correct operation of the positive break mechanism.
- Do not exceed 100 N (22.4 lb) actuation force to key to prevent switch failure (Table 1).
- Do not use the key as a stop for the door.

Failure to comply with these instructions could result in death or serious injury.

Table 1. Force Characteristics*

Key actuation force for head with detent	51 N (11.5 lb) minimum
Key extraction force for head with detent	31 N (7 lb) minimum
Key actuation force for head without detent	22 N (5 lb) minimum
Key extraction force for head without detent	2 N (0.5 lb) minimum

*Device is in unlocked state

- Ensure proper clearance for switch and key at mounting location so that operation of the auxiliary release, as well as inspection and replacement, are possible
- Properly align switch and key together before mounting to equipment
- Mount switch and key (Figures 3 and 4).
 - Torque switch to mounting surface: 4,9 N-m to 5,9 N-m [43 in-lb to 52 in-lb] M5 or #10
 - Torque key to mounting surface: 2,4 N-m to 2,8 N-m [21 in-lb to 25 in-lb] M5 or #10

Figure 3. Switch and Key Mounting Dimensions (for reference only) mm [in]

GKL shown (head of GKR is on right side of switch)

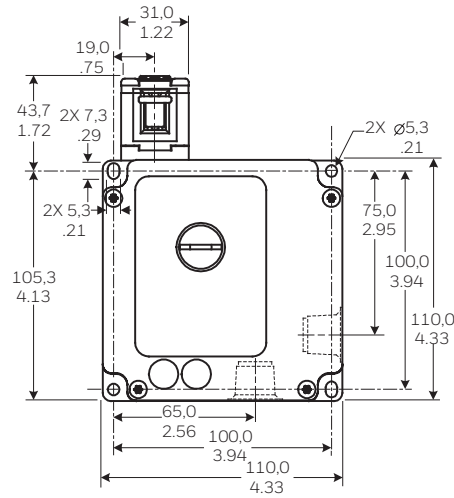
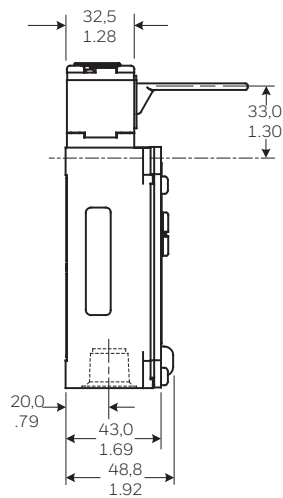
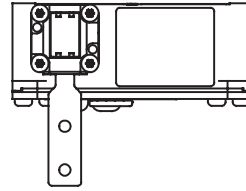

Straight Key

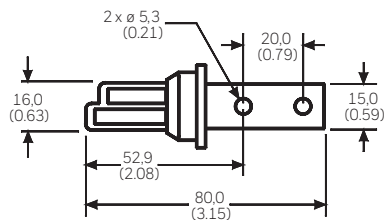

90° Key

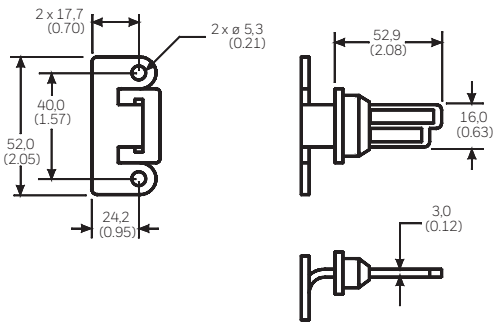

Spring-loaded Key: Up/Down

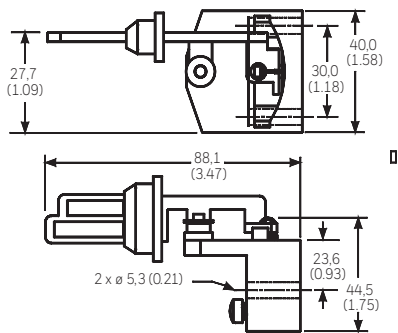

Spring-loaded Key: Left/Right

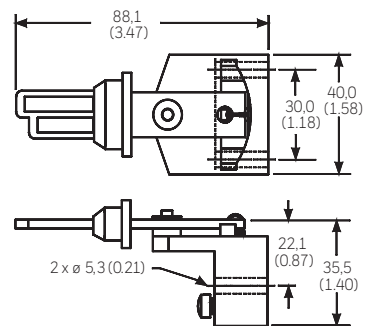
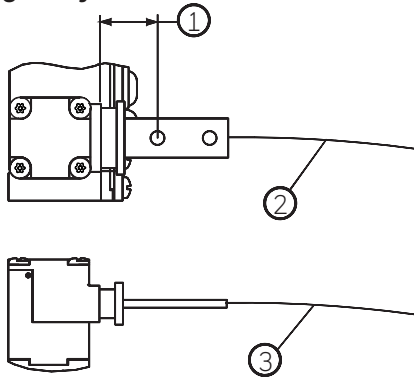
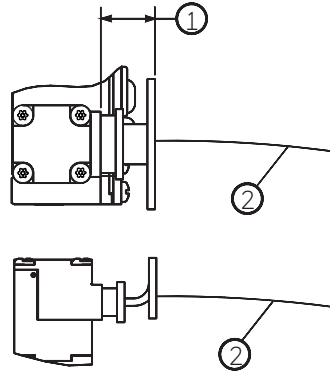

Figure 4. Minimum Key Insertion Dimensions

Straight Key



90° Key



Key

1. 23,0 mm [0.91 in] minimum insertion distance
2. 1500 mm [59.1 in] minimum swing radius
3. 1000 mm [39.4 in] minimum swing radius

Spring-loaded Key: Up/Down

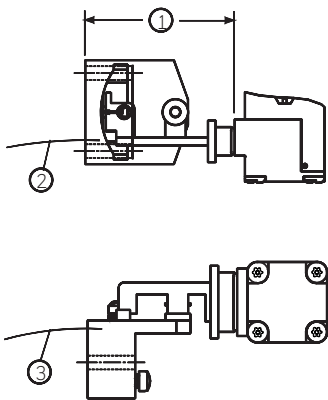

Spring-loaded Key: Left/Right

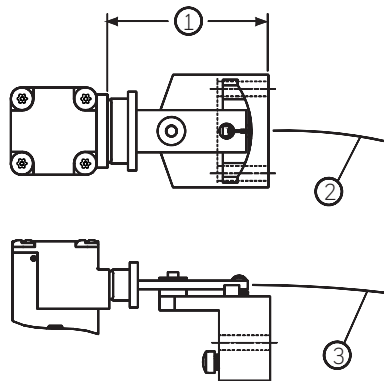

Key

1. 58,2 mm [2.29 in] minimum insertion distance
2. 150 mm [5.90 in] minimum swing radius
3. 1000 mm [39.4 in] minimum swing radius

Figure 5. Extra Switch Features

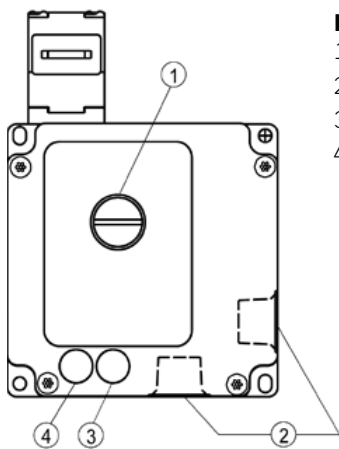

Key

1. Auxiliary release
2. Conduit entry
3. Red LED
4. Green LED

Figure 6. Internal Switch Features

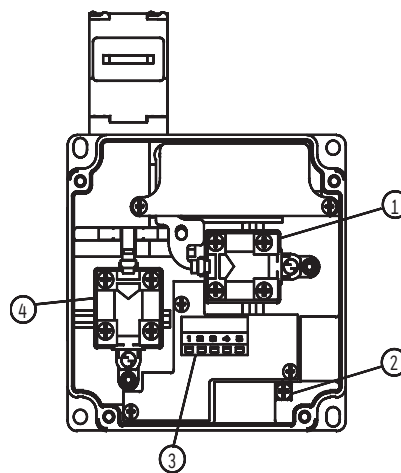

Key

1. Monitor switch (S2)
2. Ground screw
3. Terminal strip
4. Safety switch (S1)

Step 3 - Wire switch

⚠ WARNING
IMPROPER INSTALLATION

- Strictly adhere to all electrical connection instructions.

Failure to comply with these instructions could result in death or serious injury.

- Connect stranded or solid wire to switch's pressure type connector terminals. Refer to circuit diagram on switch housing. Diagram depicts safety switch when key is inserted. (Refer to Figures 5, 6, 7, and 8 for a 1NC/1NO wiring configuration.)

STOP NOTICE

- M3 spade terminals up to 6,35 mm (0.25 in) wide may be used with contact block should additional wiring be required.
- Solenoid is prewired to the terminal strip.

- Torque wire connections as follows:
 - Torque connector to secure cable to switch enclosure (if required): 1,8 N-m to 2,2 N-m (16 in-lb to 19 in-lb)
 - Torque switch terminal screws: 0,8 N-m to 1,0 N-m (7 in-lb to 9 in-lb) M3
 - Torque ground screw: 0,8 N-m to 1,0 N-m (7 in-lb to 9 in-lb) M3

Step 4 - Seal conduit entry:

- Seal with Teflon™ tape or pipe sealant
- If connector is used to secure cable to switch enclosure, torque connector to 1,8 N-m to 2,2 N-m (16 in-lb to 19 in-lb)
- Plug any unused conduit entry (plug included). Seal with Teflon tape or pipe sealant

PERFORM MECHANICAL FUNCTION TEST

- Open and close protective guard several times to ensure key slides easily into switch head

PERFORM ELECTRICAL FUNCTION TEST

- Close the protective guard and ensure switch locks. It must not be possible to open the protective guard when hazardous motion is present
- After the switch unlocks, open the protective guard. The hazardous motion must not start when the protective guard is unlocked or open

MAINTENANCE AND INSPECTION

⚠ WARNING
IMPROPER MAINTENANCE

- Strictly adhere to all maintenance and inspection instructions.
- If wear, damage, or contamination is found, replace the entire switch and key assembly. Do not replace individual parts.
- Do not exceed one million switching operations.

Failure to comply with these instructions could result in death or serious injury.

Maintenance frequency will be determined by the type of machinery, the frequency of operation, the application, and the local environment. Inspect for and correct the following:

Table 2. Routine Maintenance Checklist

✓	Switch and key mounting. Mounting should be secure and permanent
✓	Switch and key alignment. The key should move freely with no jamming in the switch during operation
✓	Wear or mechanical damage
✓	Correct electrical and mechanical switching function
✓	Switch sealing. Ensure there are no liquids in switch enclosure
✓	The complete safety switch assembly must be replaced after one million switch operations

Figure 7. Modes of Operation for 1NO/1NC Configuration

Sequence	1	2	3	4	5
Protective Guard Condition	Open	Closed	Closed	Closed	Open
Hazardous Motion	Absent	Absent	Present	Unknown	Absent
Key Actuator	Unlocked	Locked	Locked	Locked	Unlocked
Safety Circuit	Open	Closed	Closed	Closed	Open
Solenoid State	Off	Off	Off	Off	On
Mechanical Lock Solenoid Lock	Off	On	On	On	Off
Mechanical Lock Circuitry S1 = Safety Switch S2 = Monitor Switch 1-5 = PCB Terminal Strip 13-14, 21-22 = Switch Terminals Dashed Line = Internal Switch Cavity					
Solenoid Lock Circuitry S1 = Safety Switch S2 = Monitor Switch 1-5 = PCB Terminal Strip 13-14, 21-22 = Switch Terminals Dashed Line = Internal Switch Cavity					
Green LED	Off	On	On	On	Off
Red LED	On	Off	Off	Off	On

Figure 8. Terminal Strip

Key

- 1. Green LED
- 2. Red LED
- 3. Ground
- 4. Solenoid
- 5. Solenoid



AUXILIARY RELEASE DESCRIPTION (FIGURE 5)

⚠ WARNING **IMPROPER OPERATION**

Do NOT use the auxiliary release for general maintenance, repair of the machine, or to start and stop the machine. Use in an emergency situation only.

Failure to comply with these instructions could result in death or serious injury.

The auxiliary (or manual) release of the switch lock mechanism allows the protective guard to be opened. The auxiliary release is to be used in an emergency situation only, such as a power failure when the mechanical lock version is used.

- Using a screwdriver, rotate the slotted screw as follows for the listed switch versions to release:
 - Clockwise for head on left, mechanical lock; head on right, solenoid lock
 - Counterclockwise for head on left, solenoid lock; head on right, mechanical lock

LOCKING TYPES DESCRIPTION

Mechanical Lock: Occurs by internal spring force when the protective guard is closed and the key is inserted. Applying voltage to the solenoid unlocks this version (or by actuating the auxiliary release when power failure occurs).

⚠ WARNING **IMPROPER INSTALLATION**

Ensure that unintentional power failure on solenoid lock versions does not cause an unsafe condition.

Failure to comply with these instructions could result in death or serious injury.

Solenoid Lock: Occurs by applying voltage to the solenoid after the protective guard is closed and the key is inserted. Removing the voltage to the solenoid unlocks the protective guard.

LOCKING STRENGTH FEATURE

⚠ WARNING **IMPROPER OPERATION**

Do not exert over 1000 N (224 lb) extraction force on actuator key.

Failure to comply with these instructions could result in death or serious injury.

The switch is equipped with a locking mechanism to prevent damage to the switch operating head. This mechanism is designed to withstand 1000 N [224 lb]. If force over 1000 N is exerted on the actuator key, the mechanism will fracture and indicate an “open door” condition, requiring replacement of the entire switch.

ELECTRICAL RATING

A300 - AC15		Q300 - DC13	
Ue (V)	Ie (A)	Ue (V)	Ie (A)
120	6	24	2.9
240	3	125	0.55
		250	0.27

Rated insulation voltage (Ui) = 600 V

Rated impulse withstand (Uimp) = 2500 V

Rated thermal current (Ith) = 10 A

Max. rating of short circuit protective device = Class J fuse, rated 10 A, 600 V

ENVIRONMENTAL RATING

Sealing	IP68 Enclosure Type 1, 4, 6P, 12, 13
Temperature range (operating)	-25 °C to 40 °C (-13 °F to 104 °F)
Temperature range (storage)	-40 °C to 120 °C (-40 °F to 248 °F)
Shock	50 G per IEC 68-2-27
Vibration	10 G per IEC 68-2-6

SPECIFICATIONS

Solenoid power	12 W
Solenoid operating voltage	12 Vdc: +10 %, -20 % 24 Vdc: +10 %, -20 %
Contact material	Fine silver
Housing material	Zinc die cast
Mechanical life	One million operations

APPROVALS

- UL file #E37138, E157416
- CSA certified
- CE marked

REGULATION COMPLIANCE

- OSHA 29 CFR 1910.212 -- General Requirements for (Guarding of) All Machines

STANDARDS/DIRECTIVES COMPLIANCE

- The forced disconnect mechanism on normally closed contacts conforms to IEC60947-5-1
- This product complies with Machinery Directive (89/392/EEC as amended by Directive 91/369/EEC) and complies with EN60947-5-1

REPLACEMENT KEYS

Catalog Listing	Description
GKZ51	Straight key
GKZ52	90° key
GKZ53	Spring-loaded key: up/down
GKZ54	Spring-loaded key: left/right

Warranty/Remedy

Honeywell warrants goods of its manufacture as being free of defective materials and faulty workmanship during the applicable warranty period. Honeywell's standard product warranty applies unless agreed to otherwise by Honeywell in writing; please refer to your order acknowledgment or consult your local sales office for specific warranty details. If warranted goods are returned to Honeywell during the period of coverage, Honeywell will repair or replace, at its option, without charge those items that Honeywell, in its sole discretion, finds defective. **The foregoing is buyer's sole remedy and is in lieu of all other warranties, expressed or implied, including those of merchantability and fitness for a particular purpose. In no event shall Honeywell be liable for consequential, special, or indirect damages.**

While Honeywell may provide application assistance personally, through our literature and the Honeywell web site, it is buyer's sole responsibility to determine the suitability of the product in the application.

Specifications may change without notice. The information we supply is believed to be accurate and reliable as of this writing. However, Honeywell assumes no responsibility for its use.

Honeywell Sensing and Internet of Things

9680 Old Bailes Road
Fort Mill, SC 29707
honeywell.com

TORX® is a registered trademark of the Camcar Corp. division of Textron Inds
Teflon™ is a registered trademark and a brand name owned by Chemours

81591-8-EN | 8 | 12/18
© 2018 Honeywell International Inc. All rights reserved.



X-ON Electronics

Largest Supplier of Electrical and Electronic Components

Click to view similar products for [Switch Fixings](#) category:

Click to view products by [Honeywell](#) manufacturer:

Other Similar products are found below :

[893102000](#) [00-5150](#) [LZZ1A](#) [0098.9234](#) [M2PA-5011](#) [630155](#) [635401](#) [6PA113](#) [6PA147-E6](#) [6PA148-E6](#) [6PA32](#) [6PA9](#) [700106](#) [700109](#)
[700303A56](#) [700C1GRY](#) [700C2GRN](#) [704-6001](#) [704.960.9](#) [704.965.2](#) [704.965.6](#) [704.966.0](#) [7089-3](#) [710082-B11](#) [71M1048](#) [757200264](#)
[764300000](#) [MHU35](#) [MHU37](#) [807039-1](#) [825.003.011](#) [825.005.011](#) [825.053.011](#) [825.055.011](#) [826.000.071](#) [827.020.011](#) [827.400.021](#)
[835.900.023](#) [MML52C10C](#) [MML52E10C](#) [MML92HGH](#) [MML93K](#) [84211M02CNNS](#) [84212M02CNNS](#) [842.500.011](#) [843.000.011](#) [843187-](#)
[000](#) [843487-000](#) [84-901](#) [84-902](#)