

TruePoint™ Compass Module HMR3500

The HMR3500 TruePoint™ compass module is a 3-axis digital compass solution with a customizable coordinate system for mounting in any desired orientation. Three Anisotropic Magneto-Resistive sensors and three MEMs accelerometers are combined to provide compass heading as well as pitch and roll angles.

The HMR3500 has provisions for hard and soft-iron correction algorithms to handle magnetic distortion effects. In addition a World Magnetic Model feature is provided to automatically add declination angle corrections for reference to true north (geographic north).



Honeywell provides product excellence and performance by introducing innovative solid-state magnetic sensor solutions. These are highly reliable, top performance products that are delivered when promised. Honeywell's magnetic sensor products provide real solutions you can count on.

FEATURES

- ▶ Precision Compass Accuracy
- ▶ Tilt-Compensated
- ▶ Update Rate to 25Hz
- ▶ Compact Solution in a 1.97" by 1.65" by 0.52" PCB Assembly
- ▶ Hard and Soft-Iron Compensation Routines
- ▶ World Magnetic Model Included
- ▶ -40° to +85°C Operating Temp Range
- ▶ +5 DC Supply Voltage Range
- ▶ Light Weight
- ▶ Customizable Coordinate System
- ▶ All Solid State Components

BENEFITS

- ▶ Better Than 1° Nominal Heading Accuracy (1 σ), 0.1° Resolution
- ▶ $\pm 89^\circ$ Pitch and Roll, 360° Continuous Roll Capability
- ▶ Rapid Heading Computations for Guidance Applications
- ▶ Small Size for Tight Mounting Conditions, Minimal Layout Constraints
- ▶ User Driven Calibration to Null Stray Fields. A Single Routine for Both Hard and Soft Iron Corrections
- ▶ Choice of True North or Magnetic North References
- ▶ Consumer and Industrial Environment Uses
- ▶ Customizable to a Wide Variety of Power Sources
- ▶ 3.0 oz with Aluminum Housing, 0.6 oz PCB only
- ▶ 24 Custom Coordinate Orientations
- ▶ Rugged for User-Defined Orientation Plane

HMR3500

SPECIFICATIONS

Characteristics	Conditions	Min	Typ	Max	Units
-----------------	------------	-----	-----	-----	-------

Heading

Accuracy	(Clean Magnetic Environment) Level Pitch 0° to ±30° Roll 0° to ±30°	-	0.5 0.75 0.75	1	(1 σ)
Resolution			0.1		deg
Repeatability	3 sweeps, 0° to 360°, level		0.2		deg σ

Pitch and Roll

Roll Range	Default orientation, rotation about X-axis		±180°		deg
Pitch Range	Default orientation, rotation about Y-axis		±80°		deg
Accuracy	Roll ±30°, Pitch ±30°		0.5	1	deg σ
Null Accuracy ¹	Level		±0.5		deg
Resolution	Level, 1-sigma, 100 readings		0.04		deg
Roll Repeatability	Roll ±70° Pitch ±70°		0.2 0.2		deg σ
Pitch Repeatability	Roll ±70° Pitch ±70°		0.1 0.1		deg σ

Magnetic Field

Range	Maximum Magnetic Flux Density		0.7		gauss
Resolution	1-sigma, 100 readings		0.45		milli-gauss
Dip Angle	Earth's Vertical Field Component	-70		+70	deg
Linearity			0.2		%FS

Electrical

Input Voltage	Standard Product	2.5	5.0	5.2	volts DC
Power	Input Voltage 2.5 to 5.2V		300		mW

Digital Interface

UART	ASCII	4800	9600	38,400	Baud
Update Rate	Continuous Heading Updates	0.05	10	25	Hz
Format	Bi-directional binary packet data protocol.		RS-232		-

Physical

Dimensions	Circuit Board Assembly		1.97 x 1.65 x 0.52		inches
Weight	HMR3500 PCB only HMR3500 with case, no cable		0.6 3.0		ounce ounces
Connector	5-pin, 2mm pin spacing				-

Environment

Temperature	Operating	-40	-	+85	°C
	Storage (OEM only)	-55	-	+125	°C

¹ Null zeroing prior to use of the HMR3500 and upon exposure to temperature excursions beyond the Operating Temperature limits is required to achieve highest performance.

* Tested at 25°C unless stated otherwise.

HMR3500

PIN CONFIGURATION

Pin Number	Pin Name	Description
1	Ground	Power Supply Return and Ground Reference
2	RXD	RS-232 Receive Data
3	TXD	RS-232 Transmit Data
4	+Vin	Positive Power Supply Voltage Input
5	Ground	Ground Reference (for twisted pair routing with +Vin)

BASIC DEVICE OPERATION

The HMR3500 TruePoint™ Compass Module includes 3-axis Anisotropic Magneto-Resistive (AMR) sensors, 3-axis MEMS accelerometers, a temperature sensor, and 16-bit microprocessor with onboard Analog to Digital Converter (ADC). The HMR3500 is available as a printed circuit board assembly, or assembled in a black aluminum case with cable assembly. Additionally, the cable assembly can be ordered separately. A demonstration kit of the HMR3500 is available with the case, cable assembly, a CD of the CompassHost windows utility software for the user's personal computer.

The HMR3500 requires an external DC power supply for the red (positive) and black (ground) wires of the cable assembly. By feeding 5 volts at about 50 milli-amperes into the HMR3500, the compass will operate, and a red LED on the printed circuit board assembly will begin blinking at a 1Hz rate. Lack of a blinking LED or at a rapid rate is an indication of an error, and action should be taken to cycle power on the compass electronics to reset the module.

As a factory default, the RS-232 interface is set at 9600 baud with one start bit, 8 data bits, one stop bit, and no parity bits. The HMR3500 does not require any hardware or software handshaking or related features. The baud rate can be changed by command after initial communication at the current baud rate.

The CompassHost utility software is a 32-bit Windows® application program that is provided with the HMR3500 demonstration kit, and can be used to evaluate the HMR3500's performance and demonstrate the compass features. With exception of the baud rate change command, the CompassHost is capable of sending and receiving all of the commands of the compass/computer interface. Host computers should be capable of running Windows 9x, ME, NT, 2000, XP and follow-on operating systems. An install program loads the executable file CompassHost.exe and ActiveX components. A readme.txt file is also included to describe the installation process.

PHYSICAL CHARACTERISTICS

The circuit board for the HMR3500 is 1.57 by 1.97 by 0.52 inches and composed of multi-layer, fiberglass-epoxy printed boards, with the main board horizontal and a vertical board for mounting the z-axis magnetic sensor and accelerometer. The vertical board is held orthogonal to the main board by two brass hardware blocks to ensure mechanical orthogonality.

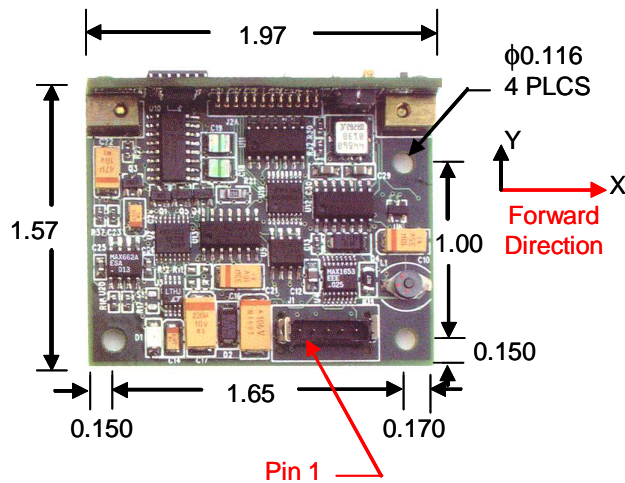

Figure 1
HMR3500 Top View and Dimensions

HMR3500

MOUNTING CONSIDERATIONS

The following is the recommend printed circuit board (PCB) footprint for the HMR3500. The reference direction (forward) is the right PCB assembly edge shown in Figure 1. Left to right, the interface connector is numbered pin 1 to pin 5 per the pin configuration table.

UNC 4-40 fastening hardware is recommended for mounting the printed circuit board with at least 0.125 inch nylon spacers to stand off the board from the mounting surface. Fastener hardware must be non-ferrous for full compass performance with brass or nylon screws the usual materials of choice.

CASE DIMENSIONS (in inches)

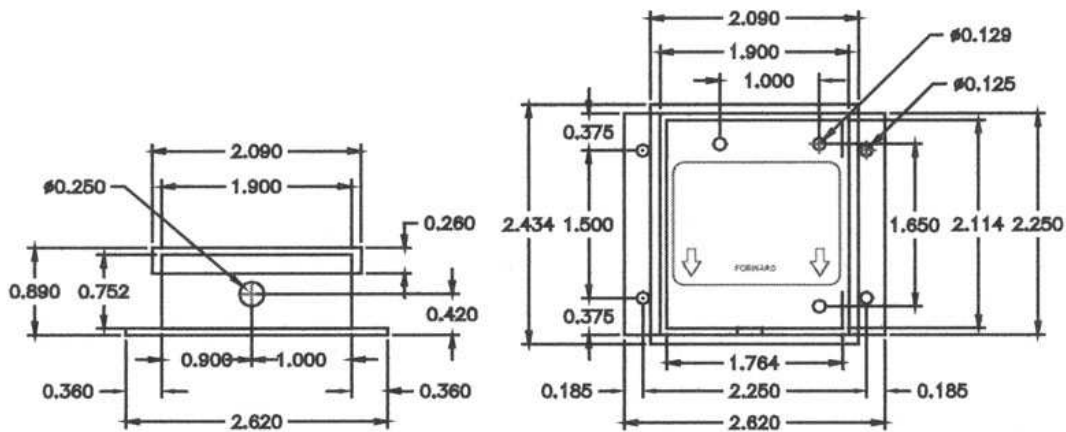

Figure 2
HMR3500 Case Dimensions

CIRCUIT DESCRIPTION

The HMR3500 circuit design starts with a microprocessor powered by power supply sub-circuit that takes the input voltage and creates regulated power for the various other circuits in the HMR3500. Two 2-axis MEMS accelerometers are mounted horizontally and vertically to combine into a 3-axis tilt sensing sub-circuit. Each accelerometer outputs a Pulse-Width-Modulated (PWM) digital signal that the microprocessor measures for pitch and roll angles.

Besides an integral temperature sensor, a 2-axis and 1-axis magnetic sensor devices are mounted horizontally and vertically to create a 3-axis measurement of the incident magnetic field upon the sensors. Each sensor output is amplified and sent to a multiplexed input ADC residing inside the microprocessor. After digitizing, the magnetic signals are corrected for hard and soft-iron magnetic errors created by the environment to which the compass is attached.

Heading computation uses the magnetic and tilt information inputs after compensation for errors. From the basic magnetic heading, a declination value may be added to arrive at a geographic north referenced heading. An index offset value may also be added to correct for mechanical installation misalignment on the target platform.

HMR3500

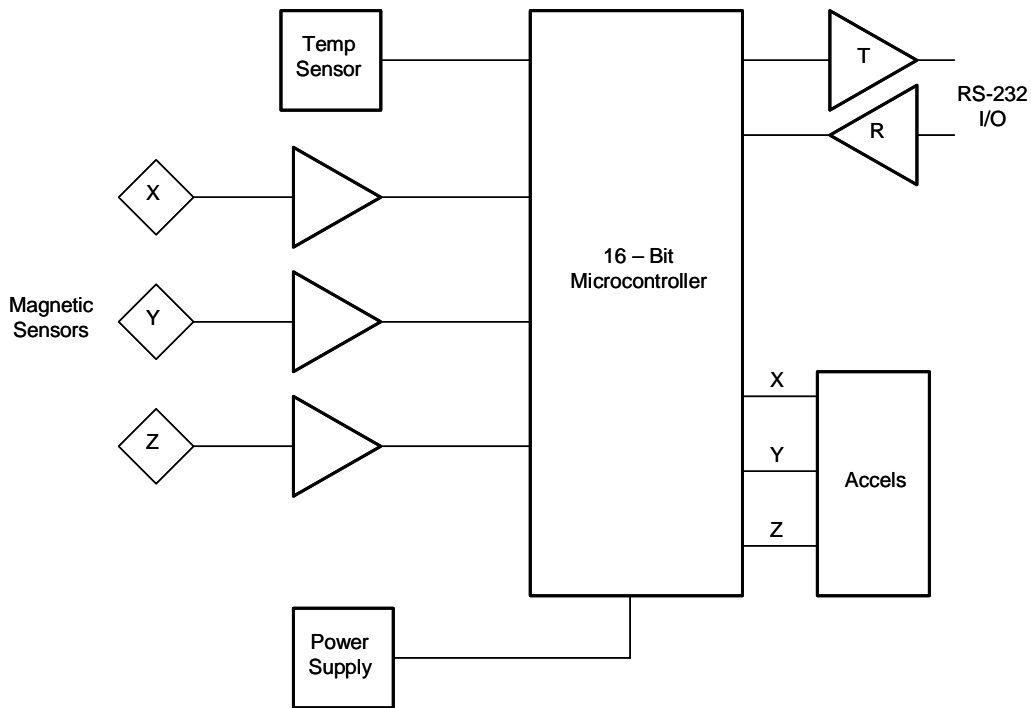

Figure 3
HMR3500 Block Diagram

UART COMMUNICATION INTERFACE

The 5-pin power supply and UART interface connector on the HMR3500, mates with a Harwin latching connector (Part # M80-8980505) per the pin configuration table earlier in this document. The interface hardware protocol is RS-232 without any further handshaking or hardware control lines.

Further HMR3500 interface commands and protocol are in the HMR3500 user's guide document.

TEST SOFTWARE DESCRIPTION

Computer test software is provided in the HMR3500 demonstration kit that will permit a thorough evaluation and demonstration of the compass capabilities. CompassHost is a 32-bit Windows test program. It is capable of sending and receiving all messages described in this manual except the BAUD message. It can display all messages received from the module in the main window with scrolling text. It has a small window summarizing the current status of the module and a graphic display of the current compass heading, roll, and pitch.

CompassHost can be run under Windows 9x, ME, NT 4.0, 2000 or their successors. One available serial port is required for communicating with the compass. Processor, memory, and disk space requirements are minimal.

The CompassHost software is not described in this datasheet, but given in depth description in the HMR3500 user's guide document.

HMR3500

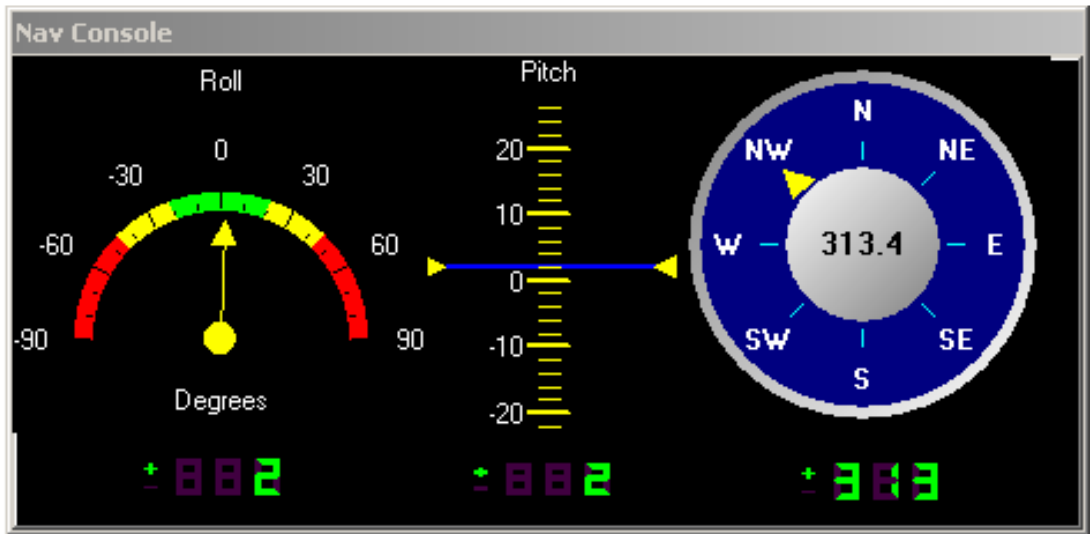

Figure 4
Compass Test Evaluation Software Display

ORDERING INFORMATION

Ordering Number	Product
HMR3500	TruePoint Compass Module PCB Only (RS232)
HMR3500 Demo	TruePoint Compass Demonstration Kit

FIND OUT MORE

For more information on Honeywell's Magnetic Sensors visit us online at www.magneticsensors.com or contact us at 800-323-8295 (763-954-2474 internationally).

The application circuits herein constitute typical usage and interface of Honeywell product. Honeywell does not warranty or assume liability of customer-designed circuits derived from this description or depiction.

Honeywell reserves the right to make changes to improve reliability, function or design. Honeywell does not assume any liability arising out of the application or use of any product or circuit described herein; neither does it convey any license under its patent rights nor the rights of others.

U.S. Patents 4,441,072, 4,533,872, 4,569,742, 4,681,812, 4,847,584 and 6,529,114 apply to the technology described



Caution
This part is sensitive to damage by electrostatic discharge. Use ESD precautionary procedures when touching, removing or inserting.

CAUTION: ESDS CAT. 1B

X-ON Electronics

Largest Supplier of Electrical and Electronic Components

Click to view similar products for [honeywell](#) manufacturer:

Other Similar products are found below :

[14CE2-2](#) [91MCE2-S5](#) [GLLA06A1B](#) [3600080010001](#) [58C1-25](#) [58C1-3K](#) [591SXP56S252SC](#) [5ML1-E1](#) [5SE1-12](#) [602HE1-6](#) [604HE223-6B](#)
[61CX11-D01](#) [M3050A13](#) [64AT22-3D](#) [66AT23-7](#) [6HM7-6](#) [MA215HT-96](#) [6PA104](#) [6PA148-E6](#) [701PB580](#) [70B1N056S202W](#) [727033](#)
[EXD-AR20](#) [MD3211Q16](#) [76054-00000700-01](#) [76061-00000015-15](#) [76061-B00000020-01](#) [76078-00000350-01](#) [76078-B00000400-01](#) [76580-](#)
[00000130-01](#) [76584-M00000100-24](#) [F78EA502](#) [F78SA102-B1](#) [77028-00001500-01](#) [77050-04000400-01](#) [78148-B00001000-01](#) [78408-](#)
[00000100-01](#) [78410-00000400-01](#) [78SF2B103](#) [7HM5](#) [FE7C-FRC6S-M](#) [FEF-PAD6-ML2](#) [FE-MLS9C](#) [FFS-20-03](#) [81808-B00000150-14](#)
[ML-1155](#) [ML-1376](#) [82000-11](#) [MLH010BGG01B](#) [MLH010BST01A](#)