

LRN Series

Reed float switch

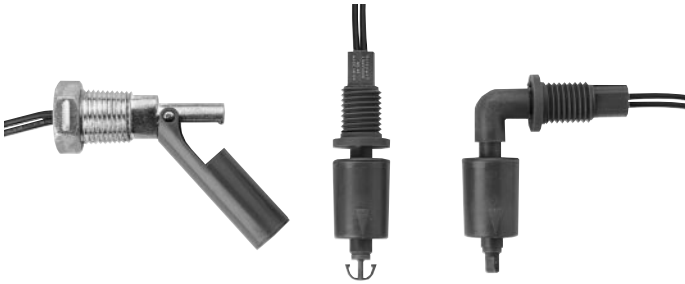

Features

- High or low level sensing
- Normally open, normally closed or change over contact action
- Ratings up to 100 W
- Operates in liquid down to S.G. of 0.65
- Internal or external fitting
- Easy to install
- Cost effective

Description

The Honeywell range of horizontal, vertical and right angled float switches offers the design engineer a combination of versatility and reed switch reliability. A magnet located in the float is used to activate the reed switch either on a rising or falling liquid level and the design allows for high or low level sensing simply by rotating the switch through 180°. A range of internal or external mounting options is available and a universal mounting kit allows both internal and external mounting. Available in Nylon 6.6 and Glass Filled Polypropylene materials and a range of switching options. LRN float switches are suitable for use in the automotive, chemical, petroleum and food processing industries in signalling and control applications.

Typical applications

- Low coolant level sensing
- Fuel or oil level sensing
- Boiler level warning
- Solution monitoring
- Flood control
- Catering and vending machine
- Domestic appliance
- Medical equipment

Technical information

Mechanical						
Minimum operate angle (horizontal models)	5° from mounting angle					
Maximum release angle (horizontal models)	40° from mounting angle					
Shock *	50 g for 11 milliseconds duration					
Vibration *	35 up to 500 Hz					
Nominal cable length	0.5 m					
Environmental						
	Nylon 6.6	Diecast metal** body	Glassfilled**** polypropylene			
Operating Temperature Range	-30 °C to +130 °C	-30 °C to +130 °C	-30 °C to +110 °C			
Minimum SG of liquid	0.85	0.85	0.65			
Minimum Viscosity of Liquid (centipoise)	100	100	100			
Plastic Housing Water absorption of equilibrium	at 20 °C and 100 % RH	1.3 %	5.6 %			
	at 100 °C and 100 % RH	1.6 %	5.6 %			
Heat distortion temperature 4.5 kg/cm ² (67.6 psig)		180 °C	245 °C			
			105 °C			
Electrical						
Switching options	0	1	2	3	4	5
Switch action	SPST		SPST	SPDT	SPST	TRIAC TRIAC
Maximum Switching Voltage (Vdc) (VRMS)	100	100	100	100		
	120	250	70	120	250	250
Maximum Switching Current (A)	1.0	1.0	0.50	3.0	3.0	1.0
dc Contact Rating (W)	15 ***	15 ***	3 ***	100 ***	750	250
Minimum Breakdown Voltage (Vdc)	300	800	200	400	-	-
Initial Contact Resistance (Ω)	0.25	0.25	0.25	0.75	-	-

* Reed Switch Only

** Diecast metal model is fitted with Nylon 6.6 float as standard

*** The switching performance can be drastically affected if switch ratings are exceeded. For inductive, capacitive and tungsten filament lamp loads, derate by 50%. All switch ratings are at dc resistive loads.

**** For boiling water applications the maximum operating temperature limits are:-
Continuous boiling water 80 °C
Non continuous boiling water 100 °C

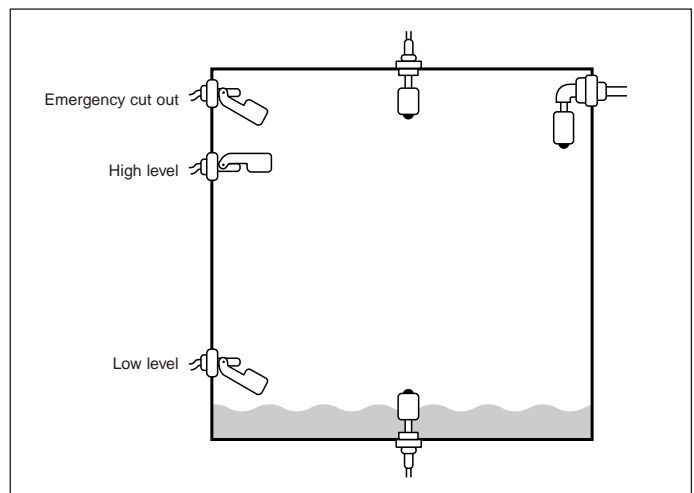

Ordering information

LRN		1	2	3	4	5	6	-	7	8	9
1 Type of orientation											
H	Horizontal										
V	Vertical										
R	Right angled										
2 Housing material											
3	Nylon 6.6 (-30 to 130 °C)										
4	Diecast metal body (-30 to 130 °C)										
5	Glass filled Polypropylene (-30 to 110 °C)										
3 Switching options											
0	S.P.S.T. 120 Vrms/1 A (15 W)										
1	S.P.S.T. 250 Vrms/1 A (15 W)										
2	S.P.D.T. 70 Vrms/0.5 A (3 W)										
3	S.P.S.T. 120 Vrms/3 A (100 W)										
4	Triac 250 Vrms/3 A										
5	Triac 250 Vrms/1 A										
4 Seal washer / Grommet											
S	Silicone										
N	Nitrile										
5 Mounting options											
0	M16 x 2 internal fit										
1	M16 x 2 external fit (compression grommet)										
2	1/2" NPT external fit										
3	1/4" NPT internal fit										
4	Universal kit (internal and external assemblies)										
6 Termination											
1	0.5 m PVC insulated leadwire										
2	2 m PVC insulated leadwire										
3	5 m PVC insulated leadwire										
4	2 m two core cable										
7, 8, 9 Customer specials											

Mounting information

Care must be taken to ensure that the product is not damaged due to excessive tightening of the fixing nut or threaded bush.

Maximum torque limits are shown below.

Model	Torque limit	Maximum container wall thickness
External fitting (compression grommet) See Note 1	2.0 lb ft (2.67 Nm)	0.16ins (4 mm)
External fitting (1/2" NPT) See Note 2	5.0 lb ft (6.75 Nm)	1.00ins (25 mm)
Internal fitting	3.0 lb ft (4.0 Nm)	0.394ins (10 mm)
Internal fitting (1/4" NPT) into tapered bush through tank wall with nut and washer	5.0 lb ft (6.75 Nm)	0.50ins (12.7 mm)
See Note 2	3.0 lb ft (4.0 Nm)	0.12ins (3 mm)

Mounting position (vertical & right angle models)	Stem position must be vertical $\pm 15^\circ$
Mounting position (horizontal models)	$\pm 30^\circ$ from horizontal

Notes:

- The compression grommet is suitable for a seal pressure of 70 psi.
- When using a 1/2" NPT external fit version, the container wall thickness must not exceed the length of male thread section of the switch. Some pipe fittings have a small diameter outside the thread area which will restrict entry. This switch is designed to pass through a 1/2" NPT tap drill 0,718" diameter. Because the mounting bush is usually metal and the switch is usually moulded plastic, care must be taken when using the 1/2" or 1/4" NPT versions not to over tighten since this will cause damage to the switch. A sealant such as PTFE tape should always be used on the NPT versions. Ensure that the position orientation arrow on the 1/2" NPT version is vertical.
- The float assembly on the horizontal models should never be removed since this will affect the switching characteristics.
- To reverse the switching action on horizontal models, simply rotate through 180° observing orientation indicator or arrow. On vertical and right angled models, compress the float stop arms, remove and reverse the float and reassemble. Movement of the float in the direction of the position indication arrow closes the switch contacts at the end of float travel.

Dimensions in inches (mm) LRN - Horizontal models

External fitting (compression grommet)

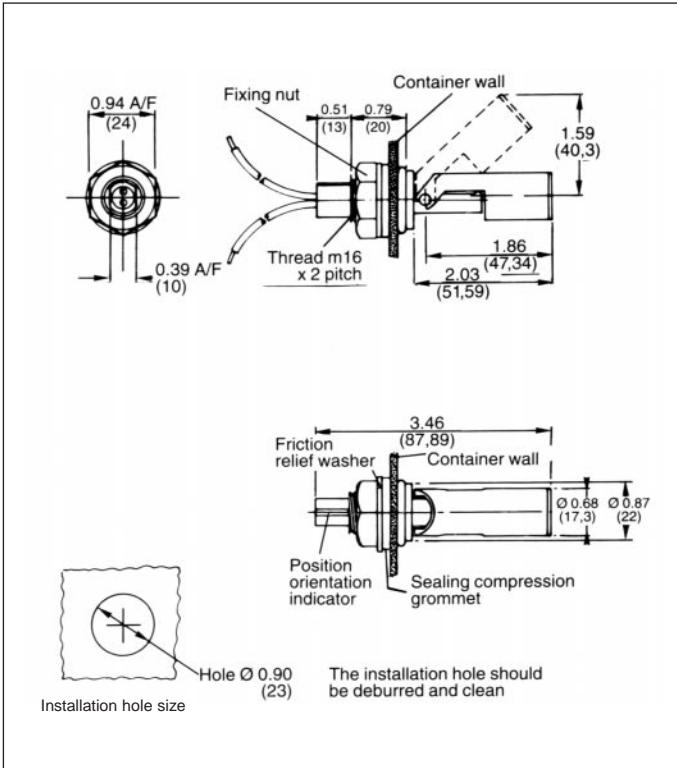

Internal fitting

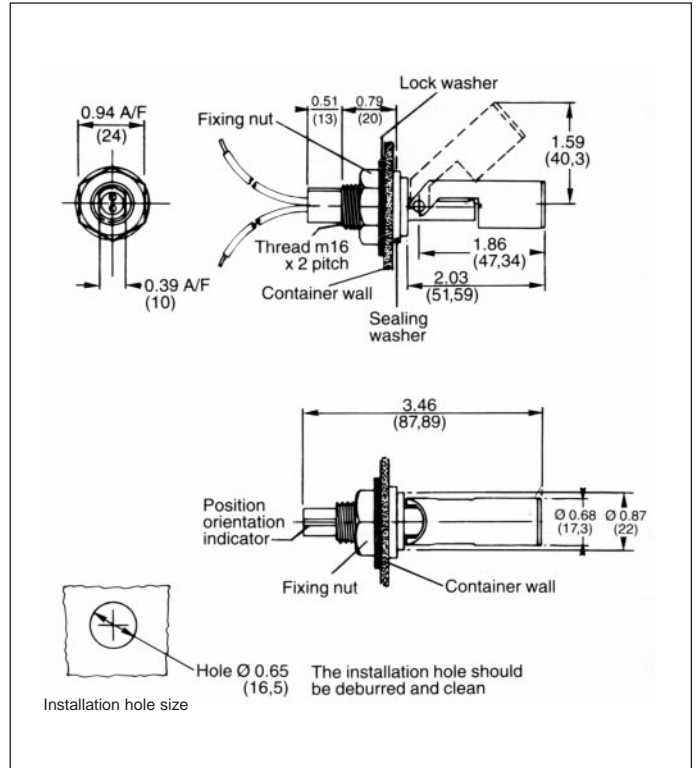

External fitting 1/2" NPT (American National Pipe Thread)

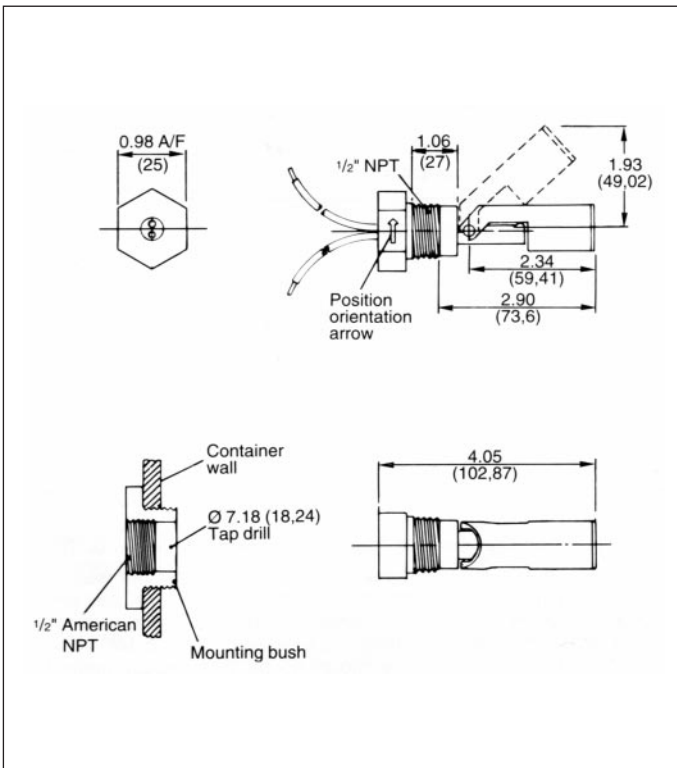

Internal fitting 1/4" NPT (American National Pipe Thread)

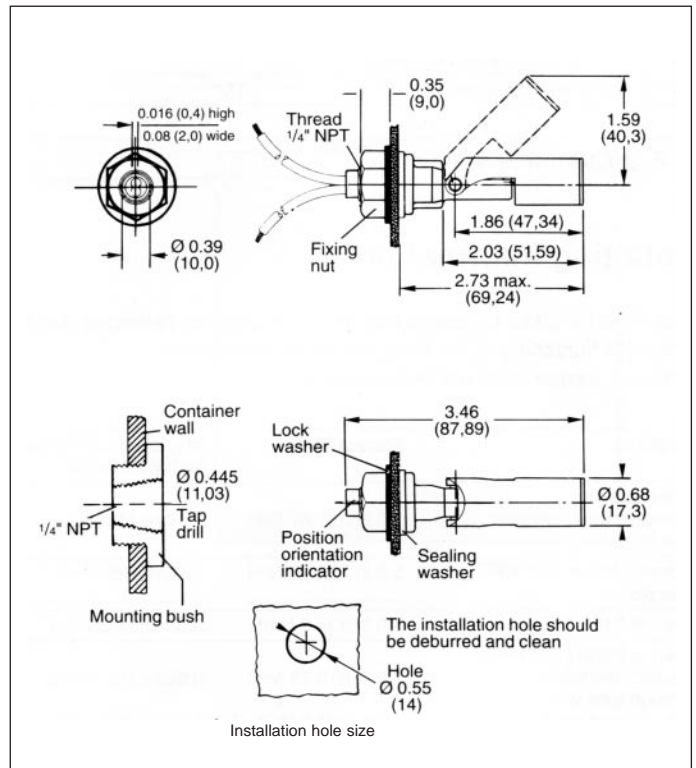

Dimensions in inches (mm) LRN - Vertical models

External fitting (compression grommet)

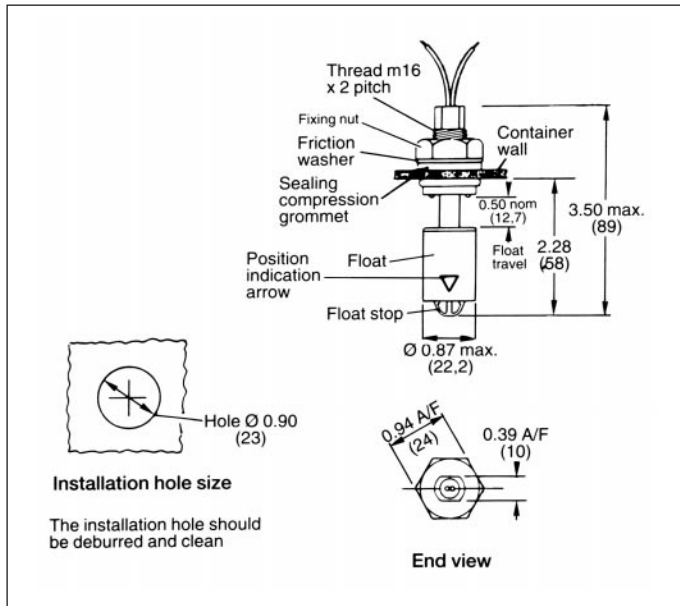

Internal fitting

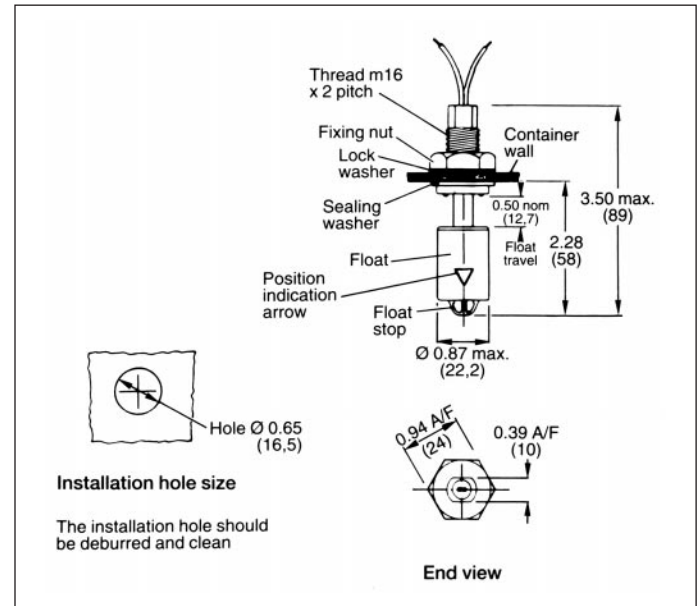

LRN - Right angle models

External fitting (compression grommet)

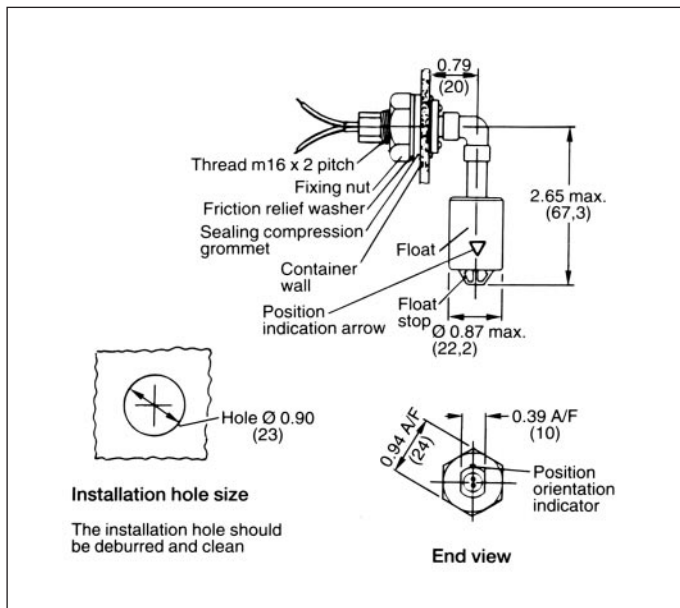

Internal fitting

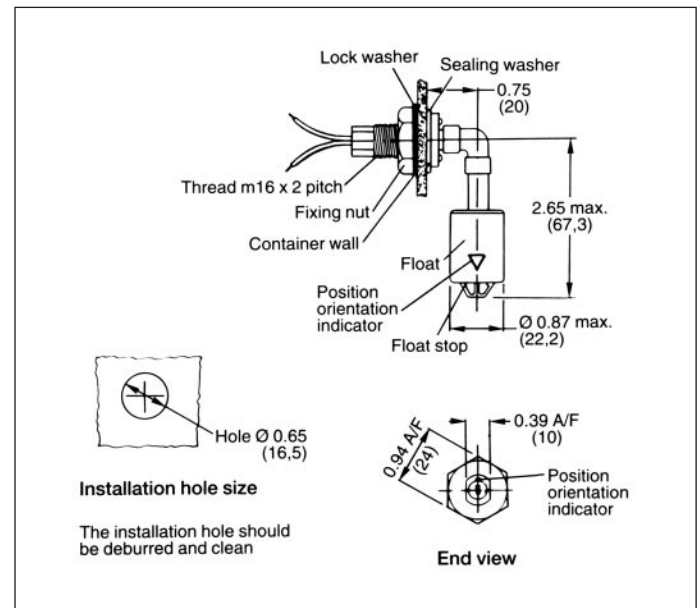

X-ON Electronics

Largest Supplier of Electrical and Electronic Components

Click to view similar products for [Liquid Level Sensors](#) category:

Click to view products by [Honeywell](#) manufacturer:

Other Similar products are found below :

[F03-16PT-1M](#) [FSH-21](#) [FSH-25](#) [FSH-34](#) [FSH-35](#) [FSV-31](#) [FSV-35](#) [LRNH31S41](#) [FSH-31](#) [RSF14Y100RF](#) [F03-16PT-10M](#) [LL01-1AB01](#)
[F03-16PS-F](#) [F03-16SF-5M](#) [F03-16PE-5M](#) [F03-16PT-5M](#) [K7L-U](#) [LBFS 1151](#) [LL8951T5](#) [SCN-1518SC](#) [LL103000](#) [LRNR31N01](#) [K7L-](#)
[AT50DB](#) [F03-16PT-2M](#) [14102](#) [RSF107H100GV](#) [MS03-PP](#) [KSL-100-1](#) [LS01-1A66-PP-2000W](#) [LS01-1B66-PP-500W](#) [LS02-1A66-S-500W](#)
[LS02-1B66-S-500W](#) [LS02-1B85-PP-5000W](#) [LS03-1A85-PP-500W](#) [LS03/DL-1A85-PA-500W](#) [RSF26H050TG](#) [EL-3N](#) [LL01-1AA01](#)
[LRNH31S42](#) [MS10C](#) [SSH66XE34N100](#) [SSH66TE34N100S](#) [TSF76H100DN](#) [TSF76H050TV](#) [OLS500D3L](#) [RSF88Y100R](#) [RSF76Y100RN](#)
[RSF54Y100RC](#) [RSF53Y100RC](#) [OLS200D3LSH](#)