

Application Note

VRS Industrial Magnetic Speed Sensors

1.0 General Information

Completely self-powered, VRS (Variable Reluctance Speed) sensors are simple, rugged devices that do not require an external voltage source for operation. (See Figure 1.)

Figure 1: VRS Sensor with Cutaway View

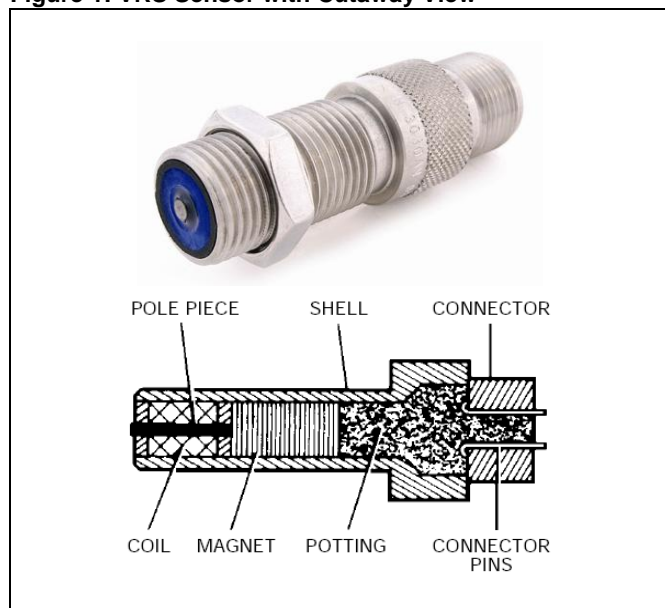

VRS sensors are generally used to provide speed, timing or synchronization data to a display (or control circuitry) in the form of a pulse train.

2.0 Potential Applications

- Engine RPM (Revolutions Per Minute) measurement on aircraft, automobiles, boats, buses, trucks and rail vehicles
- Motor RPM measurement on drills, grinders, lathes and automatic screw machines
- Process speed measurement on food, textile, woodworking, paper, printing, tobacco and pharmaceutical industry machinery
- Motor speed measurement of electrical generating equipment
- Speed measurement of pumps, blowers, mixers, exhaust and ventilating fans
- Flow measurement on turbine meters
- Motor RPM measurement on precision camera, tape recording and motion picture equipment
- Wheel-slip measurement on autos and locomotives
- Flow measurement on turbine meters
- MPH measurement on agricultural equipment

Some of the unique features that make the use of VRS sensors valuable in these potential applications include:

- Self-powered operation
- Error-free conversion of actuator speed to output frequency
- Simple installation
- No moving parts
- Useable over a wide range of speeds
- Adaptable to a wide variety of configurations

These properties have led to wide-spread use in many industries. As a result, VRS sensors are known by many use-related names such as:

- Magnetic-pickups
- Speed sensors
- Motion sensors,
- Pulse generators
- Frequency generators
- Variable reluctance sensors
- Transducers
- Magnetic probes
- Timing probes
- Monopoles
- Pick-offs

3.0 Principles of Operation

The output signal of a VRS sensor is an ac voltage that varies in amplitude and wave shape as the speed of the monitored device changes, and is usually expressed in peak-to-peak voltage (Vp-p). One complete waveform (cycle) occurs as each actuator passes the sensing area (pole piece) of the sensor.

The most commonly used actuator is a metal gear; however, bolt heads (cap screws are not recommended), keys, keyways, magnets, holes in a metal disc and turbine blades are all appropriate. In all cases, the target material must be a ferrous metal, preferably unhardened.

A permanent magnet is the heart of a VRS sensor and establishes a fixed magnetic field. An output signal is generated by changing the strength of this field. This is caused by the approach and passing of a ferrous metal target near the pole piece. The alternating presence and absence of ferrous metal (gear tooth) varies the reluctance, or "resistance of flow" of the magnetic field, which dynamically changes the magnetic field strength. This change in magnetic field strength induces a current into a coil winding which is attached to the output terminals. (See Figures 2 and 3.)

VRS Industrial Magnetic Speed Sensors

Figure 2: High Reluctance Position of Magnetic Circuit

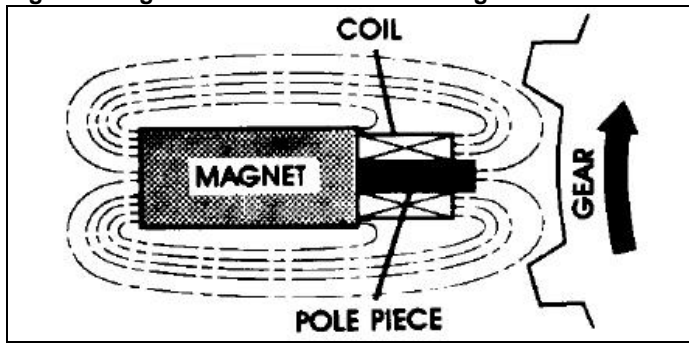
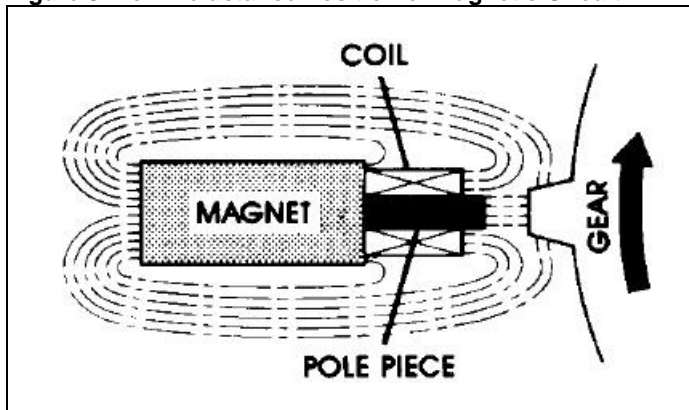

Figure 3: Low Reluctance Position of Magnetic Circuit



If a standard gear is used as an actuator, this output signal resembles a sine wave if viewed on an oscilloscope. (See Figures 4, 5, 6.)

Figure 4: Steel Fine Tooth Gear

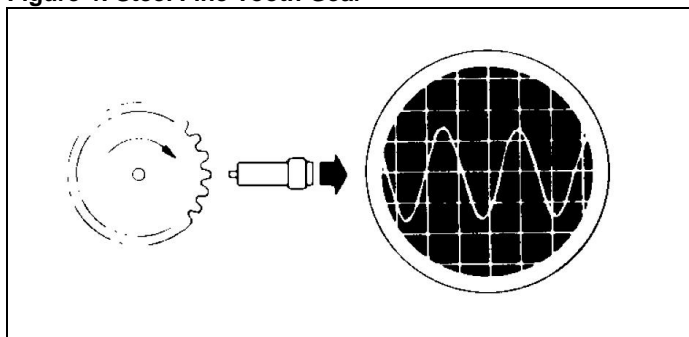

Figure 5: Steel Coarse Tooth Gear

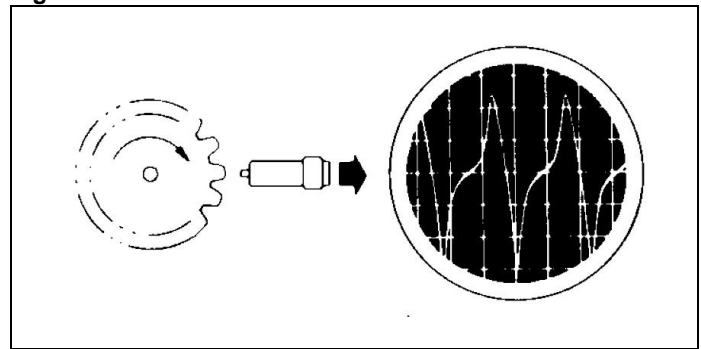
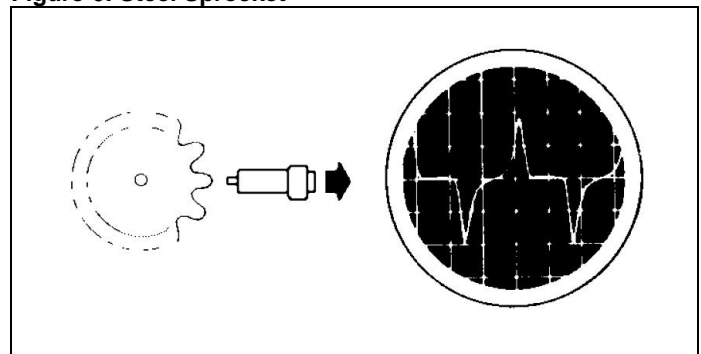

Figure 6: Steel Sprocket



4.0 Potential Application Considerations

VRS sensors are not designed for sensing extremely low speeds. The target passing the pole piece of the sensor must be traveling at a minimum velocity, or surface speed, to provide an adequate output voltage. Typical minimum surface speeds for each of Honeywell's VRS sensor product offerings can be found in the [VRS sensor product documentation](#).

Proper VRS sensor selection requires that the sensor:

- Provide the required V_{p-p} at the minimum speed of interest.
- Will still function properly at the maximum operating frequency of the application.

VRS Industrial Magnetic Speed Sensors

5.0 Standard Test Conditions

Throughout the VRS product documentation, an output voltage specification is given, expressed in Vp-p, for each sensor. This reference voltage is the minimum guaranteed peak to peak output voltage of the sensor as tested by the factory, and is the starting point for the series of calculations that will provide the actual output voltage the sensor will provide in the application. The reference voltage value is established by testing the sensor under one of the conditions in Table 1.

Table 1. Test Condition Specifications

Parameter	A	B	C
Surface speed	25 m/s [1000 IPS*]	25 m/s [1000 IPS*]	25 m/s [1000 IPS*]
Gear	20 DP (module 1.27)	8 DP (module 3.17)	8 DP (module 3.17)
Air gap	0,127 mm [0.005 in]	0,127 mm [0.005 in]	0,127 mm [0.005 in]
Load resistance	100 kOhm	100 kOhm	100 kOhm

*IPS = inches per second.

6.0 Polarity of Output

The polarity of the output signal is usually of no concern for most applications. For those situations where polarity is important, the following applies to all VRS sensors:

When ferrous metal approaches the pole piece of a given sensor:

- Pin B will be positive with respect to Pin A.
- The white lead will be positive with respect to the black lead.

7.0 Gear Tooth Configuration

For every gear tooth configuration, there is an optimum pole piece size and shape to achieve maximum output voltage from the sensor. This relationship is noted in Figure 7.

Figure 7. Optimum Gear Tooth Configuration

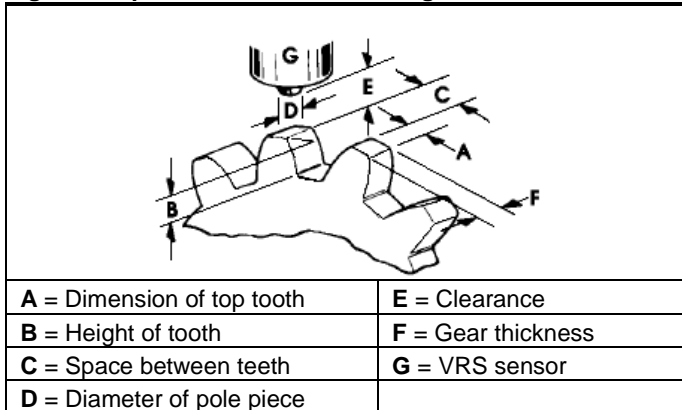

The optimum dimensions of **A**, **B** and **C** are given as they relate to **D**, the pole piece diameter of the VRS sensor being used. The optimum relationship for maximum output is as follows:

- **A** equal to or greater than **D**
- **B** equal to or greater than **C**
- **C** equal to or greater than three times **D**
- **E** as small as possible
- **F** equal to or greater than **D**

The above configuration is usually not available in a stock gear; however, it is seldom necessary to have the maximum output. Very close to the maximum output may be generated by conventional stock gears if the tooth width **A** is equal to or greater than the pole piece diameter **D** and **C** is 1.5 times **D**.

For ease of alignment, gear thickness should be two or three times the pole piece diameter.

8.0 Example Calculation: Actual Output Voltage for a Given Application

Use the following calculation sequence to determine if a certain VRS sensor will work in a specific application. In this example:

- The calculations use imperial units. For metric calculations, substitute appropriate units.
- Sensor size is not critical.
- Data for the calculations is given in Table 2.

When the actuator is a gear, an excellent starting point in choosing a sensor is to match the pole piece diameter as close as possible to the gear pitch.

Because overall sensor size is of no concern in this example, an examination of the 5/8 diameter VRS sensor shows that a 20 pitch gear is ideal for both the 3010 General Purpose and 3030 High Output devices. Note that the 3010 General Purpose device has a lower output voltage than the 3030 High Output device.

The low resistance and inductance are desirable characteristics for areas of high electrical noise and for high frequency applications. The 3030's higher output is desirable for lower speeds.

The example calculation first looks at the 3010 General Purpose device.

VRS Industrial Magnetic Speed Sensors

Table 2. Data for the Example Calculation

Required Parameter	Data
Minimum speed of interest	100 RPM
Maximum speed of interest	1000 RPM
Diameter of gear (or shaft)	<i>needs to be calculated; known gear pitch is 20</i>
Number of teeth (or actuators) per revolution.	60
Load resistance (the input resistance of the sensor being driven).	10 kOhm
Air gap setting (the distance between the pole piece and the top of gear tooth (or other actuator)).	0.010 in
Minimum acceptable Vp-p of the sensor being driven (typically a display or frequency to dc converter).	1 Vp-p min.

8.1. Calculate the gear diameter:

If a VRS sensor is going to be an appropriate choice, it must be able to work at the lowest speed of interest; however, the missing gear diameter must first be calculated:

$$\begin{aligned} \text{GEAR DIAMETER} &= \frac{\text{TOTAL \# OF TEETH} + 2}{\text{GEAR PITCH}} \\ &= \frac{62}{20} \\ &= 3.1 \text{ in} \end{aligned}$$

8.2. Calculate the minimum surface speed:

$$\begin{aligned} \text{MIN SURFACE SPEED} &= \frac{100 \times 3.1 \times 3.14}{60} \\ &= 16.2 \text{ in/s} \end{aligned}$$

8.3. Calculate the output at the calculated minimum surface speed:

The product data shows that the output of the 3010 General Purpose device is 40 Vp-p; however, this output is at 1000 IPS. The output of the 3010 General Purpose device at 16.2 IPS surface speed must be determined.

Because output voltage changes in an approximate linear response to speed, use the following ratio:

$$\begin{aligned} \frac{\text{REF VOLTAGE OUT}}{\text{REF SURFACE SPEED}} &= \frac{\text{UNKNOWN VOLTAGE OUT}}{\text{ACTUAL SURFACE SPEED}} \\ \frac{40}{1000} &= \frac{x}{16.2} \\ &= 0.648 \text{ Vp-p} \end{aligned}$$

Because the sensor needs a minimum of 1 Vp-p to operate, the 3010 General Purpose device is now disqualified as an acceptable choice.

Next, consider the higher output 3030 High Output sensors. The output of the 3030 High Output device is 190 Vp-p at 1000 IPS. Using the same ratio:

$$\begin{aligned} \frac{190}{1000} &= \frac{x}{16.2} \\ &= 3.078 \text{ Vp-p} \end{aligned}$$

8.4. Consider the gear pitch/pole piece factor.

Table 3 shows that the output from a sensor having a 0.106" dia. pole piece (3030 High Output) when sensing a 20 pitch gear is 100%. Therefore, no correction factor is applied. The output voltage remains at 3.078 Vp-p.

Table 3. Relationship Between Gear Pitch/Pole Piece Diameter/Output Voltage

Gear Pitch	Output Voltage vs Gear Pitch Expressed as a Percent of Standard Voltage							
	Conical Pole Piece				Chisel Pole Piece			
	0.187 in dia.	0.106 in dia.	0.093 in dia.	0.062 in dia.	0.040 in dia.	0.045 in dia.	0.030 in dia.	0.010 in dia.
6	125	187	146	123	134	138	117	139
8	100	172	147	118	132	135	113	134
10	98	162	149	118	130	115	120	125
12	63	157	154	114	126	110	120	118
16	29	118	130	107	124	108	120	112
20	–	100	100	100	100	100	100	100
24	–	85	99	100	100	88	83	100
32	–	23	33	100	80	70	77	81
48	–	–	20	77	53	23	47	49
64	–	–	–	30	24	–	30	36
72	–	–	–	–	–	–	13	10

VRS Industrial Magnetic Speed Sensors

8.5. Calculate the Effect of the Load Resistance of the Sensor Being Driven

In this example, the load resistance of the sensor being driven is 10 kOhm. Because this change is also a linear function, use the following ratio:

$$\frac{\text{PRESENT VOLTAGE OUT}}{\text{TOTAL RESISTANCE}^*} = \frac{\text{UNKNOWN VOLTAGE OUT}}{\text{LOAD RESISTANCE}}$$

$$\frac{3.078}{11200} = \frac{x}{10000}$$

$$= 2.748 \text{ Vp-p}$$

*Total Resistance = Load Resistance + Sensor Resistance.

Figure 8 shows the equivalent circuit in this example.

Figure 8. Equivalent Circuit

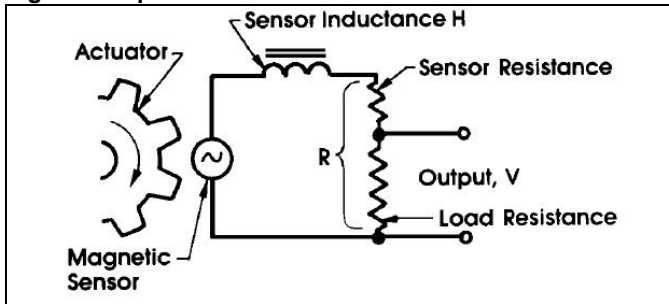

8.6. Consider the Allowable Air Gap

Air gap is also known as the pole piece clearance. In this example, the air gap is 0.010 in. Figures 9 and 10 show that the output of the 3030 High Output at 0.010 in is 60% of the present value.

Figure 9. 3030 Output for Pole Pieces Less Than 0.187 in Dia.

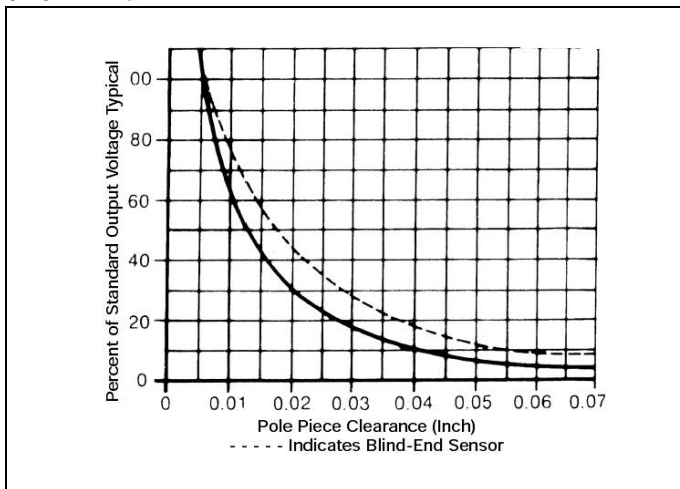
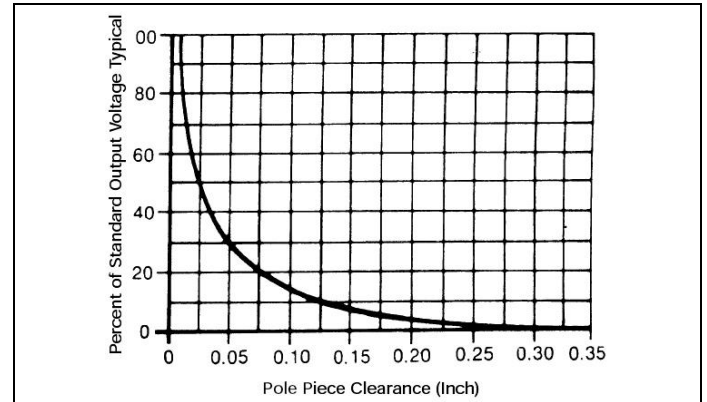

Figure 10. 3030 Output Pole Pieces Greater Than or Equal to .187 in Dia.



All the variables that have an effect on the actual output voltage at the lowest speed of interest have been considered, and the 3030 High Output device has been found to be appropriate.

If the result at this point would have been less than 1 Vp-p, it would have been necessary to look at a near-zero or zero-speed sensor for this application.

8.7. Ensure the Sensor Will Function at the Maximum Frequency of the Application

$$\text{MAX FREQUENCY} = \frac{\text{MAX RPM} \times \# \text{ OF GEAR TEETH}}{60}$$

$$= \frac{1000 \times 60}{60}$$

$$= 1000 \text{ kHz}$$

$$= 1 \text{ kHz}$$

The 3030 High Output product specifications show a typical frequency response of 15 kHz. 1 kHz is obviously well within this limit.

9.0 Sensor Selection Process Summary

- Potential applications with limited mounting space will indicate the smaller diameter sensors, then apply the previous calculations.
- When possible, select a sensor with lower coil resistance/inductance to minimize unwanted noise signals, drive lower impedance loads, and operate at higher frequencies.
- When the target allows, use a sensor with a larger pole piece diameter to provide maximum output voltage and allow use of larger air gap settings.
- Use a chisel tip pole piece to maximize output from fine gear pitches or to provide an accurate timing pulse from a similar "knife edge" type actuator.

VRS Industrial Magnetic Speed Sensors

10.0 VRS Sensor General Notes

- All housings, unless otherwise noted, are 303 stainless steel.
- Recommended cabling is twisted pair, shielded type.
- All pole pieces are conical, except 0.187 in units, which are straight, and chisel units, which are indicated where used.
- All sensors are designed to operate in moderate oil/fluid splash applications up to the rated temperature. For heavy oil/fluid splash, immersion, or if any differential pressure exists, sealed front end sensors are recommended.
- If a VRS sensor is mounted completely surrounded by ferrous metal, a 10% to 20% output voltage reduction may occur.
- Recommended max. mounting torques are given in Table 4.

Table 4. Recommended Max. Mounting Torques for Stainless Steel VRS Sensors:

Thread Size	ft-lb (max.)	N m (max.)
¾	27	36
5/8, M16	15	20
3/8, M10	3	4
¼, M8	1	1.4
10/32	0.3	0.4

WARNING

PERSONAL INJURY

DO NOT USE these products as safety or emergency stop devices or in any other application where failure of the product could result in personal injury.

Failure to comply with these instructions could result in death or serious injury.

WARNING

MISUSE OF DOCUMENTATION

- The information presented in this application sheet is for reference only. Do not use this document as a product installation guide.
- Complete installation, operation, and maintenance information is provided in the instructions supplied with each product.

Failure to comply with these instructions could result in death or serious injury.

WARRANTY/REMEDY

Honeywell warrants goods of its manufacture as being free of defective materials and faulty workmanship. Honeywell's standard product warranty applies unless agreed to otherwise by Honeywell in writing; please refer to your order acknowledgement or consult your local sales office for specific warranty details. If warranted goods are returned to Honeywell during the period of coverage, Honeywell will repair or replace, at its option, without charge those items it finds defective. **The foregoing is buyer's sole remedy and is in lieu of all other warranties, expressed or implied, including those of merchantability and fitness for a particular purpose. In no event shall Honeywell be liable for consequential, special, or indirect damages.**

While we provide application assistance personally, through our literature and the Honeywell web site, it is up to the customer to determine the suitability of the product in the application.

Specifications may change without notice. The information we supply is believed to be accurate and reliable as of this printing. However, we assume no responsibility for its use

SALES AND SERVICE

Honeywell serves its customers through a worldwide network of sales offices, representatives and distributors. For application assistance, current specifications, pricing or name of the nearest Authorized Distributor, contact your local sales office or:

E-mail: info.sc@honeywell.com

Internet: www.honeywell.com/sensing

Phone and Fax:

Asia Pacific +65 6355-2828; +65 6445-3033 Fax

Europe +44 (0) 1698 481481; +44 (0)

1698 481676 Fax

Latin America +1-305-805-8188; +1-305-883-8257 Fax

USA/Canada +1-800-537-6945; +1-815-235-6847

+1-815-235-6545 Fax

Sensing and Control
Honeywell
1985 Douglas Drive North
Golden Valley, MN 55422
www.honeywell.com/sensing

005934-2-EN
June 2012
Copyright © 2012 Honeywell International Inc. All rights reserved.

Honeywell

X-ON Electronics

Largest Supplier of Electrical and Electronic Components

Click to view similar products for [Speed Sensors](#) category:

Click to view products by [Honeywell](#) manufacturer:

Other Similar products are found below :

[621405](#) [M3050A13](#) [MA215HT-96](#) [726324](#) [726446](#) [727033](#) [727440-08](#) [727440-28](#) [728265-02](#) [993AB18AT-J](#) [SNDJ-CNT-G03](#) [M3024](#)
[M3030](#) [M3040](#) [M3040AN25](#) [34.170.1001.0](#) [4953](#) [ZS-180-B55](#) [ZS-1963](#) [ZS-2048](#) [ZS-2147](#) [04.241.8053.0](#) [04.845.2253.0](#) [EN401B](#) [SNDH-](#)
[SPR-001](#) [70.331.1028.0](#) [70.331.2428.0](#) [70.377.2428.0](#) [725004](#) [725204](#) [725733](#) [725951](#) [727397](#) [727440-27](#) [728143-15](#) [728202-02](#) [PA11560](#)
[PA12D03](#) [ZS-1952](#) [ZS-1728-D](#) [SNDJ-CNT-G04](#) [SNDH-SPC-01M](#) [SNDH-H3C-G07](#) [4951957-8](#) [REVK](#) [722543](#) [LCZA460](#) [728098-07](#)
[SNDH-SPC-01P](#) [727470](#) [3040AN40](#)