

## Oxymac50, DE800, Elecdit

---

### Oxygen Sensor Interface Boards

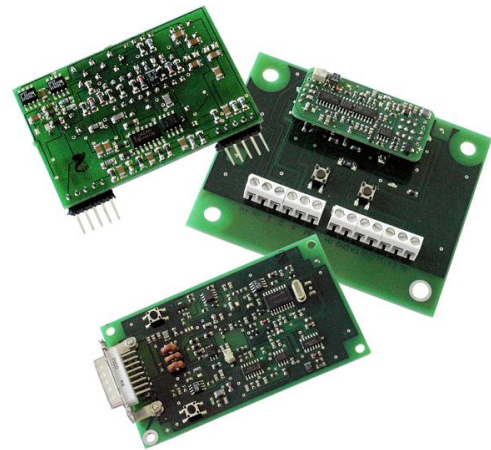

#### DESCRIPTION

The Oxymac 50, Elecdit and DE800 sensor interface boards are control and measurement devices for Honeywell's range of dynamic, highly accurate oxygen sensors. The ability of these sensors to operate without any reference gas makes them ideal for potential applications such as combustion and environmental control.

Honeywell oxygen sensors using zirconia-based sensing elements require external connection to an electronic measuring circuit to control sensor operation and signal processing.

A heating element on the sensor produces the 700 °C [1292 °F] required for the ZrO<sub>2</sub> to achieve its operational temperature. These interface boards supply the sensor with the necessary circuits to provide this control and processing, while also providing sensor calibration. The DE800 interface also includes the heater supply, while the Oxymac50 and Elecdit require an external heater power supply.

#### FEATURES AND BENEFITS

---

- Provides the necessary circuits to control Honeywell oxygen sensors which removes the need to implement sensor control circuits within the customers' equipment
- Functional testing and calibration in ambient air removes effects of barometric or application pressure
- PCB board format provides ease of mounting and calibration access
- Linear output of measured oxygen content in voltage or current format for a flexible interconnection
- Low power consumption for lower running costs

Oxymac50 is a recently upgraded interface that offers similar performance to the Elecdit board but operates from a 24 Vdc power supply.

The DE800 interface offers the features of the Oxymac50 but also contains the heating element power source.

The Elecdit interface was developed for Industrial applications and offers a level of noise protection. It operates from a ±15 V supply.

Oxymac50 and DE800 are the recommended interfaces for new applications.

The interfaces are supplied ready for mounting into customers' enclosures. Oxymac50 a 15-pin D type connector, DE800 has screw connector block and Elecdit has 2,5 mm x 2,5 mm [0.1 in x 0.1 in] pin connector.



#### POTENTIAL APPLICATIONS

---

- Boiler combustion controls
- Aircraft oxygen generation systems

# Oxymac50, DE800, Elecdit

Table 1. Technical Specifications<sup>1</sup>

Characteristic	Oxymac50 	DE800 	Elecdit 
Measuring range	0% to 25% oxygen (standard) 0% to 100% oxygen (option)		
Power source	+24 Vdc ±20%	+24 Vdc ±20%	±15 Vdc ±10%
Other inputs	calibration trigger, sensor pump, sense and common, test	calibration trigger, sensor pump, sense, common, heater, test	calibration trigger, sensor pump, sense and common
Power consumption (interface)	<250 mW	<500 mW	<250 mW
Outputs	0 V to 10 V, 4 mA to 20 mA <sup>2</sup>	4 mA to 20 mA, 0 V to 10 V <sup>2</sup> , pulse	0 V to 10 V, LED drive
Accuracy	2% full scale		
Resolution	0.04 V		
Operating temperature	-10 °C to 60 °C [14 °F to 140 °F]		
Storage temperature	-10 °C to 50 °C [14 °F to 122 °F]		
Dimensions	63 mm x 108 mm [2.48 in x 4.25 in]	80 mm x 100 mm [3.12 in x 3.98 in]	60 mm x 42 mm x 17 mm [2.36 in x 1.65 in x 0.67 in]
Mounting holes	4 mm [0.16 in] dia.	6,5 mm [0.26 in] dia.	—
Connector	15 pin male D connector	screw connector block	2 x 5 pin 2,5 mm x 2,5mm [0.1 in x 0.1 in]
Mates with	GMS-10, KGZ-10, KGZ-12		

**Notes:**

1. For warm up time and other sensor characteristics, refer to datasheet 100470-EN.
2. Factory set to voltage or current output.

**OPERATING AND CALIBRATION NOTES (See Figure 1**

**Oxymac50**

- Reset the Oxymac50 by turning the power off/on.
- The output signal may be 0 V to 10 V or 4 mA to 20 mA. It is factory set by the solder bridge JP1.
- Proper operation of a connected sensor and electronic circuit may be tested with the test switch or with an external signal.
- The output signal should indicate a 20% lower value after switching the test function.
- A blinking LED D3 indicates proper sensor operation.
- The sensor and Oxymac50 circuit may be calibrated in normal air. The Oxymac50 circuit stores the calibration value after a power loss.

**DE800**

- The heater voltage of the sensor may be adjusted with pot meter PC419.
- After pressing the test button, the output must go to a 20% lower output signal. Testing with an external (24 V) signal is possible via terminal TE.
- The sensor may be calibrated in normal air with the calibration button. Calibration is lost after power loss.
- A blinking LED D4 indicates proper sensor operation.
- A pulse signal may be measured at terminal K2 if the sensor is functioning properly.

**Elecdit**

The interface is factory set. Follow these adjustment/calibration instructions for sensor replacement:

1. Adjust Pot1 to 12 V (internal ±6 V) at Pin 2.
2. Adjust Pot2 to reference at Pin 1 to 10 V ±0.2 V.
3. After approx 60 s an impulse (blinking) signal should be present at Pin 1. Apply 95 mbar air at the sensor, adjust Pot5 at Pin 9 to 0.8 V, then apply 1013 mbar air at the sensor and adjust Pot3 at Pin 9 Uout to 8.3 V.
4. Adjust Pot4 to 0 mV at Pin 10.
5. Adjust Pot5 to Uout to 0 V at Pin 9.

# Oxygen Sensor Interface Boards

Figure 1. Electrical Connection Diagrams

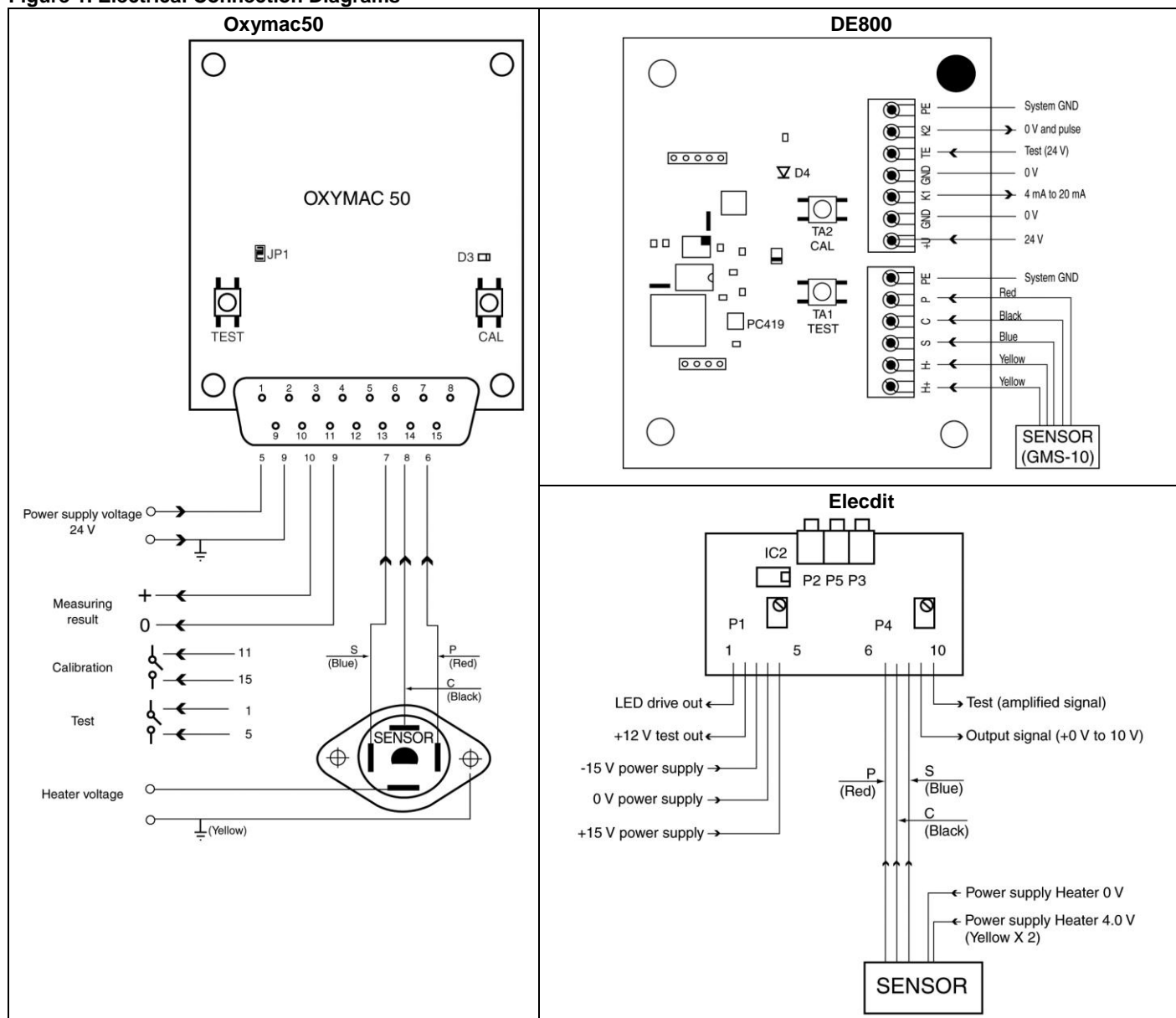

**Order Guide**

Catalog Listing	Description
Oxymac 50.V.1	Oxymac50 circuit, output 0 V to 10 V, measuring range 0% to 25%
Oxymac 50.V.2	Oxymac50 circuit, output 0 V to 10 V, measuring range 0% to 100%
Oxymac 50.A.1	Oxymac50 circuit, output 4 mA to 20 mA, measuring range 0% to 25%
Oxymac 50.A.2	Oxymac50 circuit, output 4 mA to 20 mA, measuring range 0% to 100%
DE800.V.1	DE800 circuit, output 0 V to 10 V, measuring range 0% to 25%
DE800.V.2	DE800 circuit, output 0 V to 10 V, measuring range 0% to 100%
DE800.A.1	DE800 circuit, output 4 mA to 20 mA, measuring range 0% to 25%
DE800.A.2	DE800 circuit, output 4 mA to 20 mA, measuring range 0% to 100%
ElecDit.V.1	ElecDit circuit, output 0 V to 10 V, measuring range 0% to 25%
ElecDit.V.2	ElecDit circuit, output 0 V to 10 V, measuring range 0% to 100%

**⚠ WARNING**

**PERSONAL INJURY**

DO NOT USE these products as safety or emergency stop devices or in any other application where failure of the product could result in personal injury.

**Failure to comply with these instructions could result in death or serious injury.**

**⚠ WARNING**

**MISUSE OF DOCUMENTATION**

- The information presented in this product sheet is for reference only. Do not use this document as a product installation guide.
- Complete installation, operation, and maintenance information is provided in the instructions supplied with each product.

**Failure to comply with these instructions could result in death or serious injury.**

**WARRANTY/REMEDY**

Honeywell warrants goods of its manufacture as being free of defective materials and faulty workmanship. Honeywell's standard product warranty applies unless agreed to otherwise by Honeywell in writing; please refer to your order acknowledgement or consult your local sales office for specific warranty details. If warranted goods are returned to Honeywell during the period of coverage, Honeywell will repair or replace, at its option, without charge those items it finds defective. **The foregoing is buyer's sole remedy and is in lieu of all other warranties, expressed or implied, including those of merchantability and fitness for a particular purpose. In no event shall Honeywell be liable for consequential, special, or indirect damages.**

While we provide application assistance personally, through our literature and the Honeywell web site, it is up to the customer to determine the suitability of the product in the application.

Specifications may change without notice. The information we supply is believed to be accurate and reliable as of this printing. However, we assume no responsibility for its use.

**SALES AND SERVICE**

Honeywell serves its customers through a worldwide network of sales offices, representatives and distributors. For application assistance, current specifications, pricing or name of the nearest Authorized Distributor, contact your local sales office or:

**E-mail:** [info.sc@honeywell.com](mailto:info.sc@honeywell.com)

**Internet:** [www.honeywell.com/sensing](http://www.honeywell.com/sensing)

**Phone and Fax:**

Asia Pacific +65 6355-2828  
+65 6445-3033 Fax  
Europe +44 (0) 1698 481481  
+44 (0) 1698 481676 Fax  
Latin America +1-305-805-8188  
+1-305-883-8257 Fax  
USA/Canada +1-800-537-6945  
+1-815-235-6847  
+1-815-235-6545 Fax

Sensing and Control  
Honeywell  
1985 Douglas Drive North  
Golden Valley, MN 55422  
[www.honeywell.com/sensing](http://www.honeywell.com/sensing)

100480-2-EN IL50 GLO Printed in USA  
July 2011  
Copyright © 2011 Honeywell International Inc. All rights reserved.

**Honeywell**

## X-ON Electronics

Largest Supplier of Electrical and Electronic Components

*Click to view similar products for [Air Quality Sensors](#) category:*

*Click to view products by [Honeywell](#) manufacturer:*

Other Similar products are found below :

[GMS-MSTH2.S.V.3](#) [MO86571](#) [MO86561](#) [076074 01](#) [DE800.A.1](#) [MF010-2-LC1](#) [MF020-2-LC3](#) [KGZ10-5PIN](#) [GMS10SENSORS](#) [IR25TT](#)  
[208280-0001](#) [IR11BD](#) [IR11GM](#) [IR12GM](#) [IR21BD](#) [GMS10-18C](#) [KGZ12](#) [S-300L-3V-5000-SLEEP-UART](#) [MP7227-TC](#) [SGPC3-TR-2.5KS](#)  
[T6713-6H](#) [POLOLU-1482](#) [3.000.475](#) [3.000.496](#) [HPMA115S0-XXX](#) [SGPC3-2.5k](#) [T3032-2-10K-24-P](#) [VQ6MB](#) [INIR-CD-5%](#) [VQ23TB](#)  
[IR11GJ](#) [VQ31MB](#) [IR11BR](#) [GP2Y1026AU0F](#) [VQ549ZD](#) [MHM501-00](#) [MHM500-00A](#) [MHM305-01](#) [MICS-4514](#) [VQ548ZD-S](#) [SEN-09403](#)  
[IR15TT](#) [MICS-5524](#) [MICS-5914](#) [MICS-2714](#) [INIR-ME-100%](#) [T8100-D](#) [VQ21TB](#) [IR21EJ](#) [VQ603/2](#)