

## SOT-89 Plastic-Encapsulate Transistors

### Features

- Complementary to 2SA1797
- Power dissipation of 500mW
- High stability and high reliability
- Meets MSL level 1, per J-STD-020, LF maximum peak of 260°C

### Mechanical Data

- Case: SOT-89  
Molding compound meets UL 94V-0 flammability rating, RoHS-compliant, halogen-free
- Terminals: Solder plated, solderable per MIL-STD-750, Method 2026

### Function Diagram

XXX = Device Code  
DKP = 2SC4672-P  
DKQ = 2SC4672-Q  
DKR = 2SC4672-R

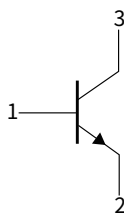
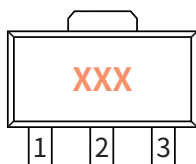

**Collector-Base Voltage**  
VCBO 60V  
**Collector Current**  
2.0 Ampere

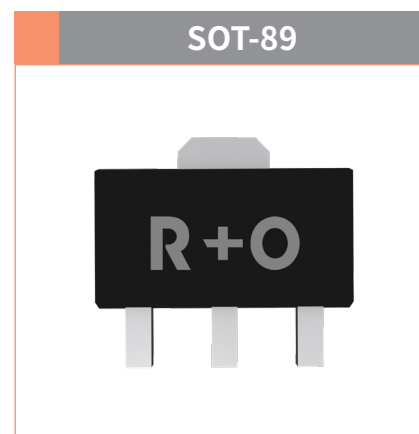

### Maximum Ratings (Ta=25°C Unless otherwise specified)

PARAMETER	SYMBOL	UNIT	VALUE
Collector-Base Voltage	$V_{CBO}$	V	60
Collector-Emitter Voltage	$V_{CEO}$		50
Emitter-Base Voltage	$V_{EBO}$		6.0
Collector Current	$I_C$	A	2.0
Collector Power Dissipation	$P_C$	mW	500
Storage temperature	$T_{stg}$	°C	-55 ~+150
Junction temperature	$T_j$	°C	-55 ~+150
Typical Thermal Resistance	$R_{\theta J-A}$	°C /W	250

### Electrical Characteristics (Ta=25°C Unless otherwise noted)

PARAMETER	SYMBOL	UNIT	Condition	Min	Max
Collector-Base Breakdown Voltage	$V_{(BR)CBO}$	V	$I_C=50\mu A, I_E=0$	60	—
Collector-Emitter Breakdown Voltage	$V_{(BR)CEO}$		$I_C=1.0mA, I_B=0$	50	—
Emitter-Base Breakdown Voltage	$V_{(BR)EBO}$		$I_C=50\mu A, I_C=0$	6.0	—
Collector-Base cut-off current	$I_{CBO}$	nA	$V_{CB}=60V, I_E=0$	—	100
Emitter-Base cut-off current	$I_{EBO}$		$V_{EB}=5.0V, I_C=0$	—	100
DC Current Gain	$h_{FE(1)}$	—	$I_C=0.5A, V_{CE}=2.0V$	82	390
Collector-Emitter Saturation Voltage	$V_{CE(sat)}$	V	$I_C=1.0A, I_B=50mA$	—	0.35
Base-Emitter Saturation Voltage	$V_{BE(sat)}$	V	$I_C=1.0A, I_B=50mA$	—	1.0

● **Classification Of  $h_{FE}$**

RANK	P	Q	R
Range	82-180	120-270	180-390

● **Small-signal Characteristics**

ITEM	SYMBOL	Condition	UNIT	Min	Typ	Max
Transition frequency	$f_T$	$I_E=-0.5A, V_{CE}=2V, f=100MHz$	MHZ	—	210	—

● **Ordering Information**

PACKAGE	PACKAGE CODE	UNIT WEIGHT(g)	REEL(pcs)	BOX(pcs)	CARTON(pcs)	DELIVERY MODE
SOT-89	R1	0.055	1000	7000	21000	7"

● **Ratings And Characteristics Curves** ( $T_a=25^\circ C$  Unless otherwise specified)

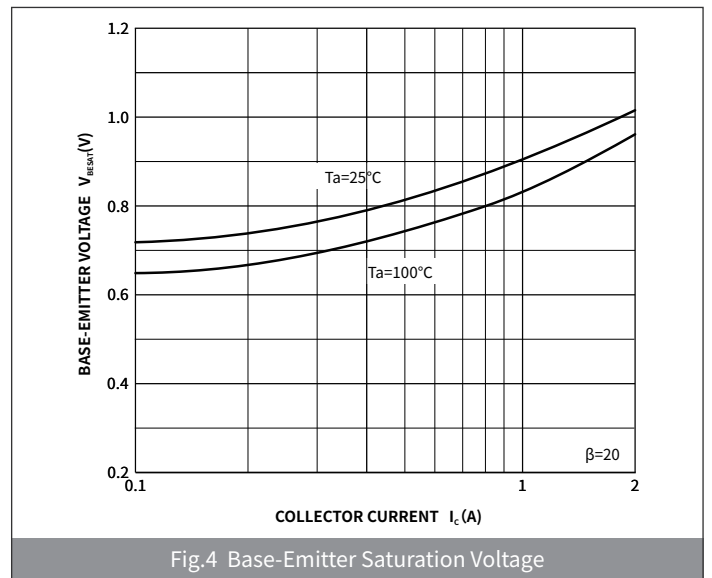
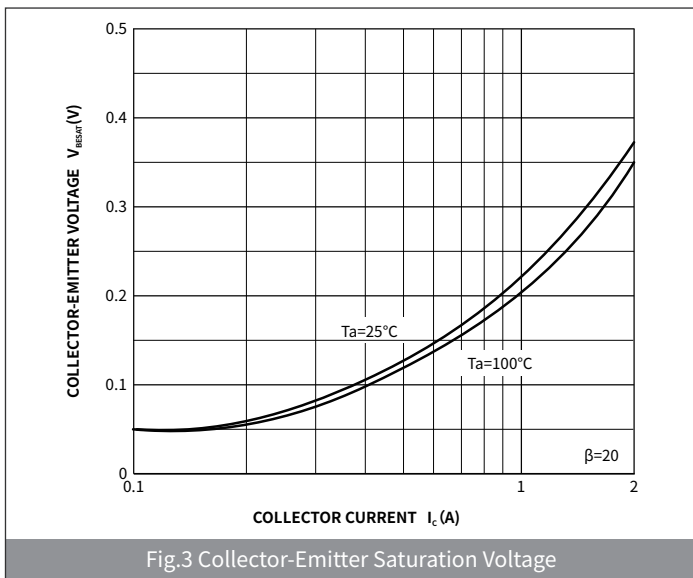
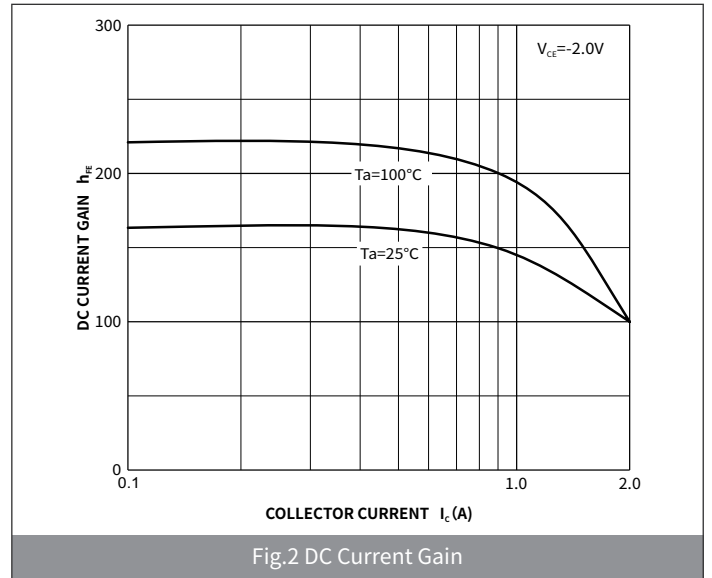
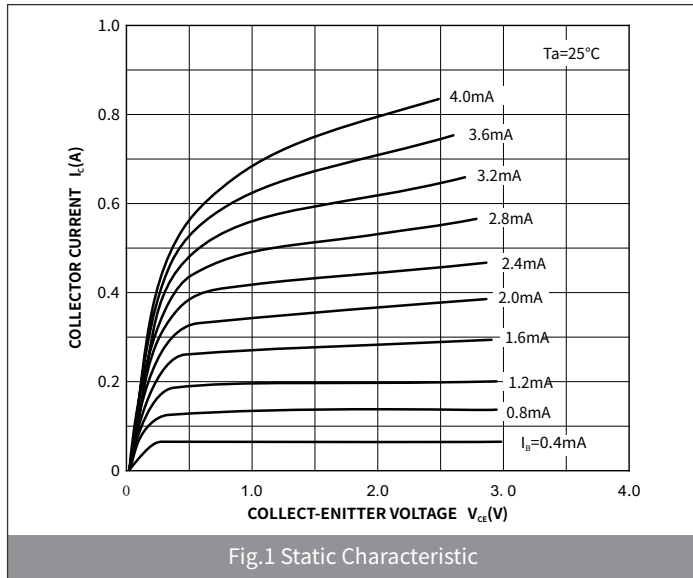

● **Ratings And Characteristics Curves** ( $T_a=25^{\circ}\text{C}$  Unless otherwise specified)

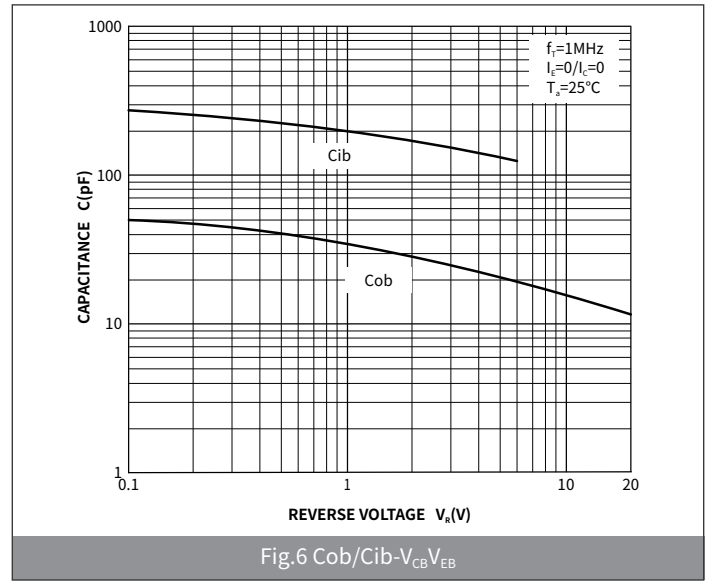
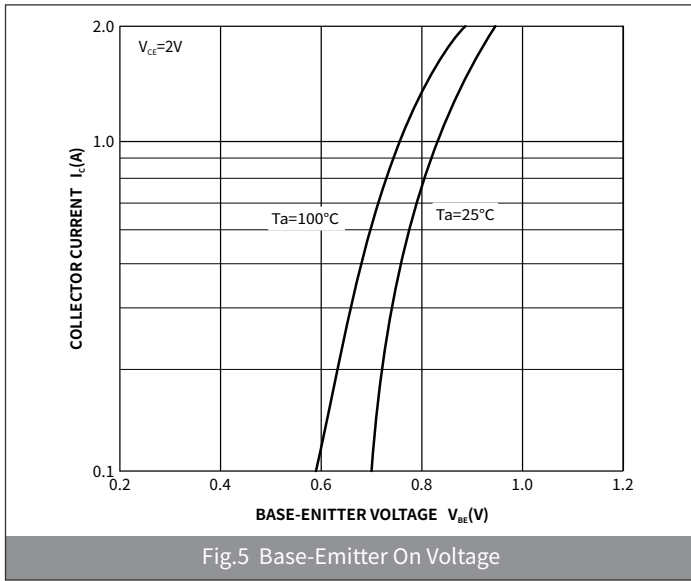

● **Package Outline Dimensions** (SOT-89)

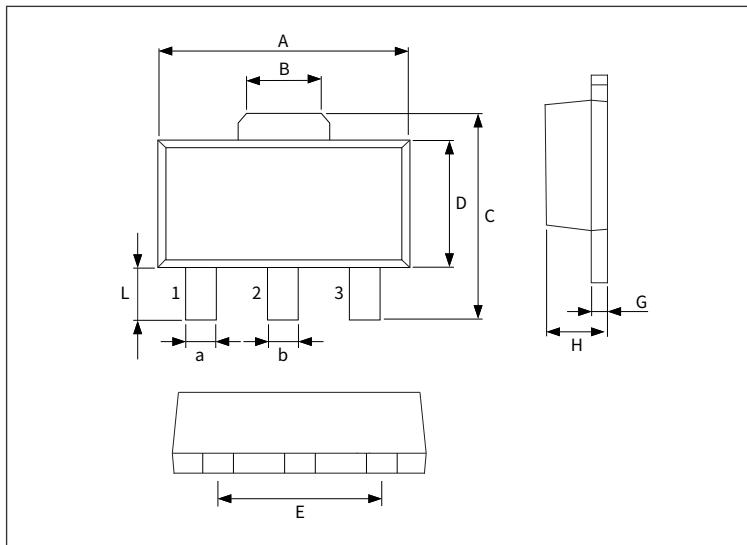

Symbol	Dimensions			
	Millimeters		Inches	
	Min.	Max.	Min.	Max.
A	4.4	4.6	0.176	0.184
B	1.6	1.8	0.064	0.072
C	3.9	4.1	0.156	0.164
D	2.4	2.6	0.096	0.104
E	2.9	3.1	0.116	0.124
a	0.41	0.43	0.0164	0.018
b	0.35	0.45	0.014	0.018
L	0.95	1.05	0.037	0.041
G	0.3	0.5	0.012	0.020
H	1.4	1.5	0.055	0.059

● **Suggested Pad Layout**

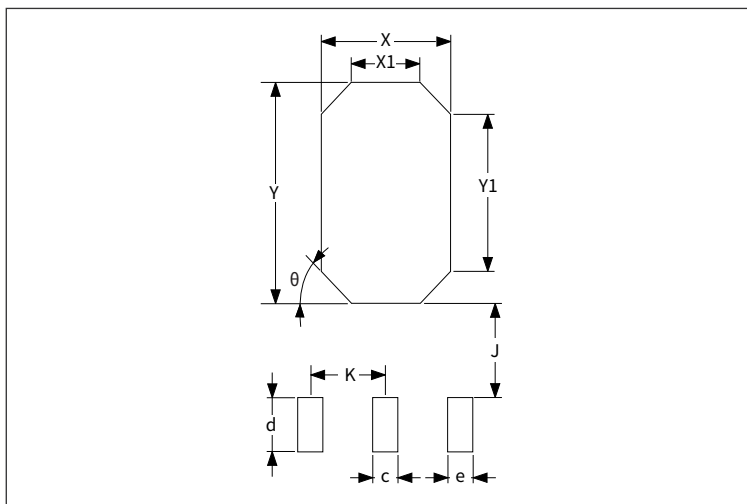

Symbol	Dimensions			
	Millimeters		Inches	
	Min.	Max.	Min.	Max.
c	0.80	1.00	0.032	0.04
d	1.30	1.50	0.052	0.060
e	0.70	0.90	0.028	0.036
J	1.80	2.00	0.072	0.080
K	1.40	1.60	0.056	0.064
X	2.50	2.70	0.100	0.108
X1	1.30	1.50	0.052	0.060
Y	4.30	4.50	0.172	0.180
Y1	3.10	3.30	0.124	0.132
$\theta$	-	45°	-	45°

## X-ON Electronics

Largest Supplier of Electrical and Electronic Components

*Click to view similar products for [Bipolar Transistors - BJT category](#):*

*Click to view products by [hongjiacheng manufacturer](#):*

Other Similar products are found below :

[BC559C](#) [MCH4017-TL-H](#) [MMBT-2369-TR](#) [BC546/116](#) [NJVMJD148T4G](#) [NTE16](#) [NTE195A](#) [IMX9T110](#) [2N4401-A](#) [2N6728](#) [2SA1419T-TD-H](#) [2SB1204S-TL-E](#) [2SC5488A-TL-H](#) [FMC5AT148](#) [2N2369ADCSM](#) [2N2907A](#) [2N3904-NS](#) [2N5769](#) [2SC4618TLN](#) [CPH6501-TL-E](#) [BC856BW-13-F](#) [US6T6TR](#) [BAX18/A52R](#) [BC556/112](#) [IMZ2AT108](#) [MMST8098T146](#) [MCH6102-TL-E](#) [BC846B-13-F](#) [2N3879](#) [30A02MH-TL-E](#) [NTE13](#) [NTE282](#) [NTE323](#) [NTE350](#) [NTE81](#) [JANTX2N2920L](#) [JANSR2N2907AUB](#) [CMLT3946EG TR](#) [SNSS40600CF8T1G](#) [CMLT3906EG TR](#) [GRP-DATA-JANS2N2907AUB](#) [GRP-DATA-JANS2N2222AUA](#) [MMDT3946FL3-7](#) [2N4240](#) [JANS2N3019](#) [MSB30KH-13](#) [2N2221AUB](#) [2SD1815T-TL-E](#) [2N6678](#) [2N2907Ae4](#)