

SOT-23 Plastic-Encapsulate Transistors

Features

- Complementary to MMBT2907A
- Power dissipation of 300mW
- High stability and high reliability
- Meets MSL level 1, per J-STD-020, LF maximum peak of 260°C

Mechanical Data

- Case: SOT-23
Molding compound meets UL 94V-0 flammability rating, RoHS-compliant, halogen-free
- Terminals: Solder plated, solderable per MIL-STD-750, Method 2026

Function Diagram

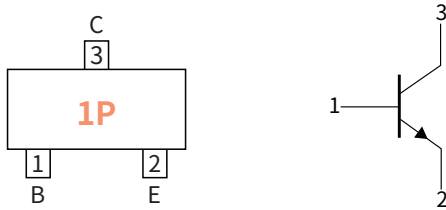

Collector-Base Voltage

VCBO 75V

Collector Current

-0.6 Ampere

SOT-23

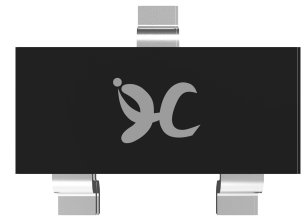

Maximum Ratings (Ta=25°C Unless otherwise specified)

PARAMETER	SYMBOL	UNIT	VALUE
Collector-Base Voltage	V_{CBO}	V	75
Collector-Emitter Voltage	V_{CEO}		40
Emitter-Base Voltage	V_{EBO}		6.0
Collector Current	I_C	A	0.6
Collector Power Dissipation	P_C	mW	300
Storage temperature	T_{stg}	°C	-55 ~+150
Junction temperature	T_j	°C	-55 ~+150
Typical Thermal Resistance	$R_{\theta J-A}$	°C /W	417

Electrical Characteristics (Ta=25°C Unless otherwise noted)

PARAMETER	SYMBOL	UNIT	Condition	Min	Max
Collector-Base Breakdown Voltage	V_{CBO}	V	$I_C=10\mu A, I_E=0$	75	—
Collector-Emitter Breakdown Voltage	V_{CEO}		$I_C=10mA, I_B=0$	40	—
Emitter-Base Breakdown Voltage	V_{EBO}		$I_E=10\mu A, I_C=0$	6.0	—
Collector-Base cut-off current	I_{CBO}	μA	$V_{CB}=60V, I_E=0$	—	0.01
Collector cut-off current	I_{CEX}		$V_{CE}=30V, V_{EB(off)}=3.0V$	—	0.01
Emitter-Base cut-off current	I_{EBO}		$V_{EB}=3.0V, I_C=0$	—	0.1
DC Current Gain	h_{FE}	—	$I_C=0.1mA, V_{CE}=10V$	40	—
			$I_C=150mA, V_{CE}=10V$	100	300
			$I_C=500mA, V_{CE}=10V$	42	—
Collector-Emitter Saturation Voltage	$V_{CE(sat)1}$	V	$I_C=500mA, I_B=50mA$	—	1.0
Collector-Emitter Saturation Voltage	$V_{CE(sat)2}$		$I_C=150mA, I_B=15mA$	—	0.3
Base-Emitter Saturation Voltage	$V_{BE(sat)1}$		$I_C=500mA, I_B=50mA$	—	2.0
Base-Emitter Saturation Voltage	$V_{BE(sat)2}$		$I_C=150mA, I_B=15mA$	—	1.2
Delay time	t_d	ns	$V_{CC}=30V, V_{BE(off)}=-0.5V$ $I_C=150mA, I_{B1}=15mA$	—	10
Rise time	t_r			—	25
Storage time	t_s		$V_{CC}=30V, I_C=150mA$ $I_{B1}=I_{B2}=15mA$	—	225
Fall time	t_f			—	60

● Classification Of h_{FE}

RANK	L	H
Range	100-200	200-300

● Small-signal Characteristics

ITEM	SYMBOL	Condition	UNIT	Min	Max
Transition frequency	f_T	$I_C=20mA, V_{CE}=20V, f=100MHz$	MHz	300	—

● Ordering Information

PACKAGE	PACKAGE CODE	UNIT WEIGHT(g)	REEL(pcs)	BOX(pcs)	CARTON(pcs)	DELIVERY MODE
SOT-23	R1	0.008	3000	30000	120000	7"

● Ratings And Characteristics Curves (Ta=25°C Unless otherwise specified)

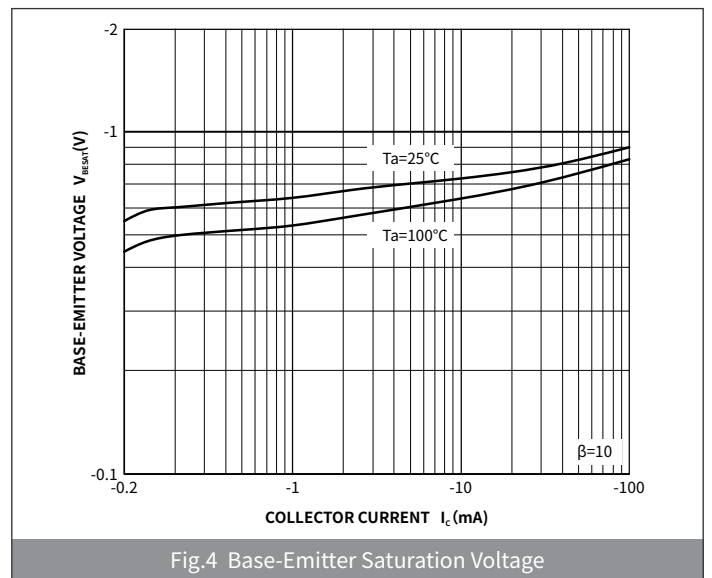
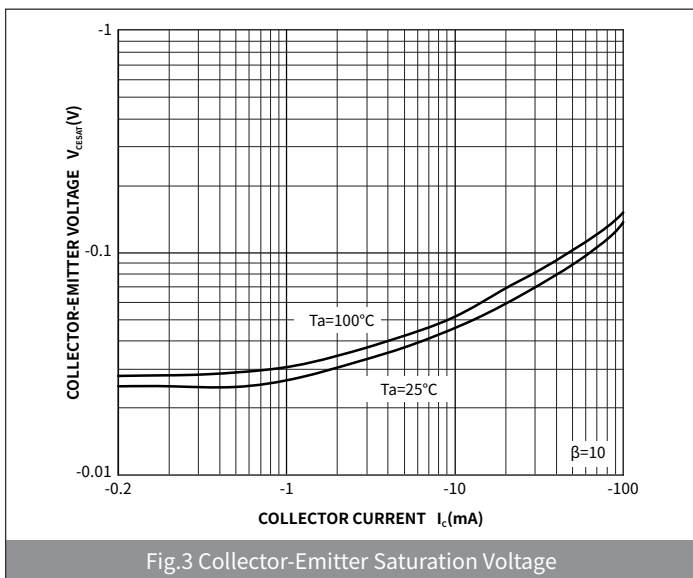
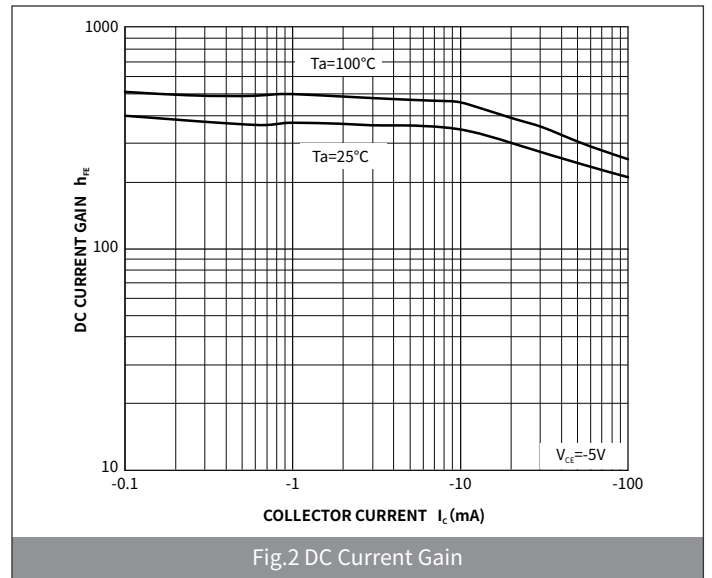
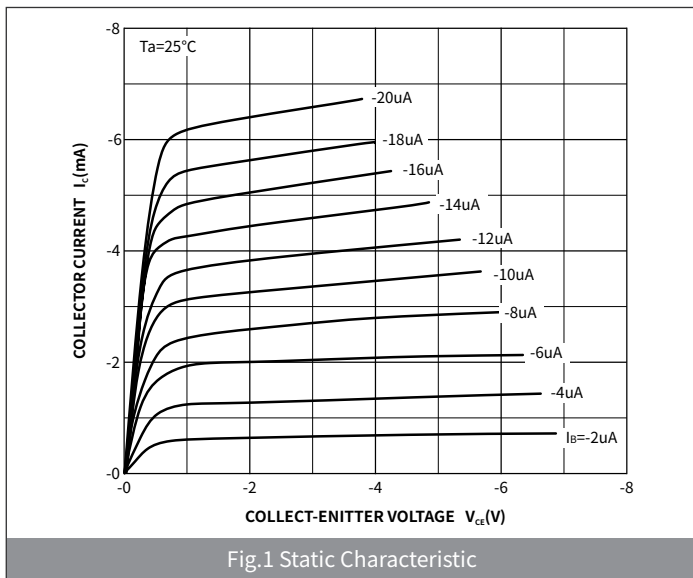

● Ratings And Characteristics Curves (Ta=25°C Unless otherwise specified)

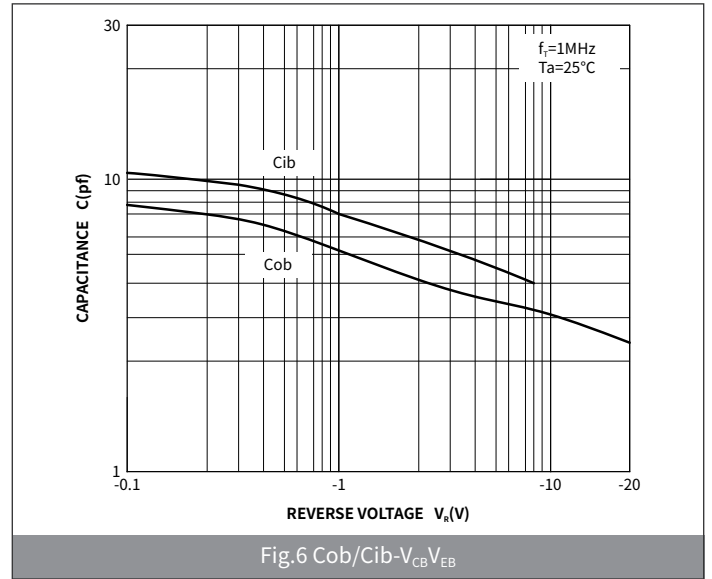
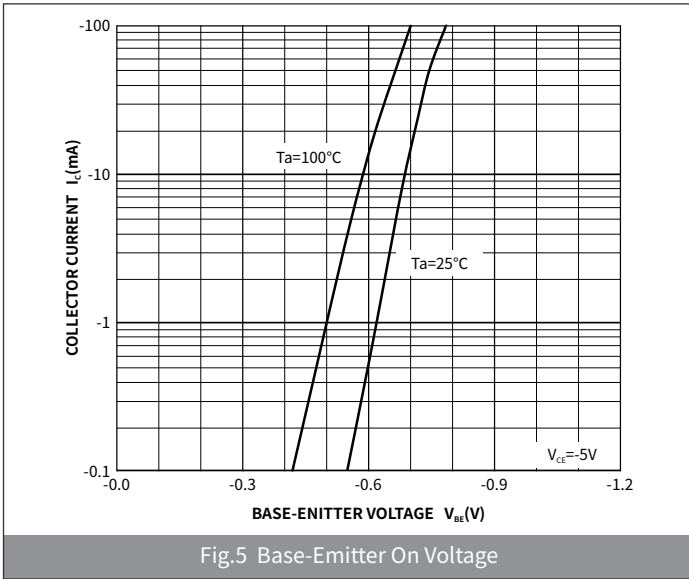

● Package Outline Dimensions (SOT-23)

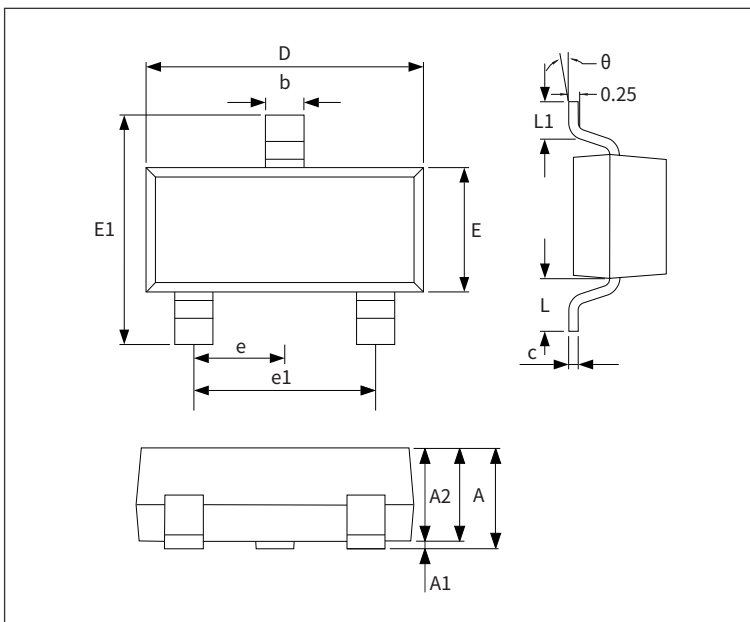

Symbol	Dimensions			
	Millimeters		Inches	
	Min.	Max.	Min.	Max.
A	0.90	1.15	0.035	0.045
A1	-	0.10	-	0.004
A2	0.90	1.05	0.035	0.041
b	0.30	0.50	0.012	0.020
c	0.10	0.20	0.004	0.008
D	2.80	3.00	0.110	0.118
E	1.20	1.40	0.047	0.055
E1	2.25	2.55	0.089	0.100
e	0.950TYP		0.037TYP	
e1	1.80	2.00	0.071	0.079
L	0.550REF		0.022REF	
L1	0.30	0.50	0.012	0.020
θ	-	8°	-	8°

● Suggested Pad Layout

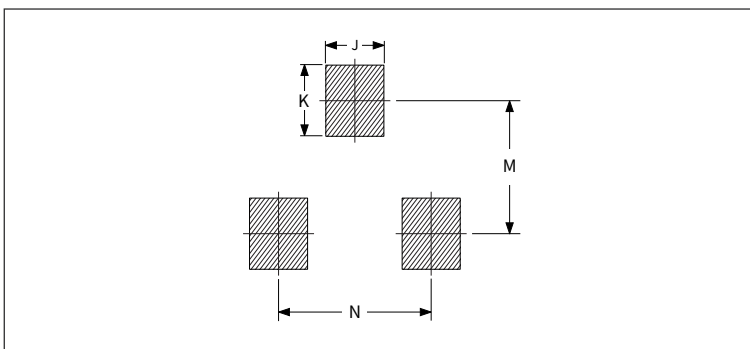

Symbol	Dimensions			
	Millimeters		Inches	
	Min.	Max.	Min.	Max.
J	0.75	0.85	0.030	0.033
K	0.85	0.95	0.033	0.037
M	1.95	2.05	0.077	0.081
N	1.85	1.95	0.073	0.077

X-ON Electronics

Largest Supplier of Electrical and Electronic Components

Click to view similar products for [Bipolar Transistors - BJT category](#):

Click to view products by [hongjiacheng manufacturer](#):

Other Similar products are found below :

[BC559C](#) [MCH4017-TL-H](#) [MMBT-2369-TR](#) [BC546/116](#) [NJVMJD148T4G](#) [NTE16](#) [NTE195A](#) [IMX9T110](#) [2N4401-A](#) [2N6728](#) [2SA1419T-TD-H](#) [2SB1204S-TL-E](#) [2SC5488A-TL-H](#) [FMC5AT148](#) [2N2369ADCSM](#) [2N2907A](#) [2N3904-NS](#) [2N5769](#) [2SC4618TLN](#) [CPH6501-TL-E](#) [US6T6TR](#) [BAX18/A52R](#) [BC556/112](#) [IMZ2AT108](#) [MMST8098T146](#) [MCH6102-TL-E](#) [BC846B-13-F](#) [2N3879](#) [30A02MH-TL-E](#) [NTE13](#) [NTE282](#) [NTE323](#) [NTE350](#) [NTE81](#) [JANTX2N2920L](#) [JANSR2N2907AUB](#) [CMLT3946EG TR](#) [SNSS40600CF8T1G](#) [CMLT3906EG TR](#) [GRP-DATA-JANS2N2907AUB](#) [GRP-DATA-JANS2N2222AUA](#) [MMDT3946FL3-7](#) [2N4240](#) [JANS2N3019](#) [MSB30KH-13](#) [2N2221AUB](#) [2SD1815T-TL-E](#) [2N6678](#) [2N2907Ae4](#) [JAN2N3507](#)