

Digital Transistors (Built-in Resistors)

• Equivalent Circuit

DIGITAL TRANSISTOR (PNP)

FEATURES

- Built-in bias resistors enable the configuration of an inverter circuit without connecting external input resistors(see equivalent circuit)
- The bias resistors consist of thin-film resistors with complete isolation to allow negative biasing of the input.They also have the advantage of almost completely eliminating parasitic effects
- Only the on/off conditions need to be set for operation, making device design easy

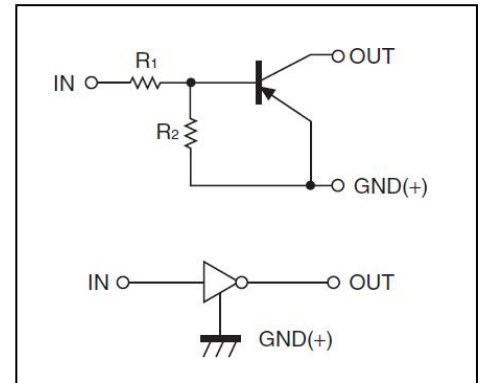

PIN CONNENCTIONS and MARKING

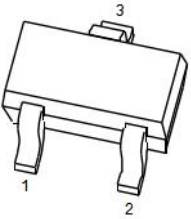
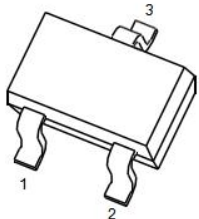
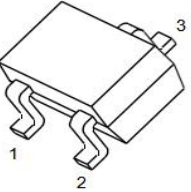
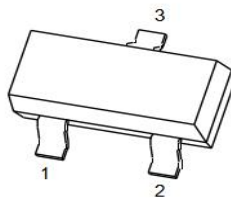
DTA114YE 	SOT-523 1. IN 2. GND 3. OUT	DTA114YUA 	SOT-323 1. IN 2. GND 3. OUT
DTA114YKA 	SOT-23-3L 1. IN 2. GND 3. OUT	DTA114YCA 	SOT-23 1. IN 2. GND 3. OUT

ORDERING INFORMATION

Part Number	MARKING	Package	Packing Method	Pack Quantity
DTA114YE	54	SOT-523	Reel	3000pcs/Reel
DTA114YUA	54	SOT-323	Reel	3000pcs/Reel
DTA114YKA	54	SOT-23-3L	Reel	3000pcs/Reel
DTA114YCA	54	SOT-23	Reel	3000pcs/Reel

MAXIMUM RATINGS(Ta=25°C unless otherwise noted)

Symbol	Parameter	Limits(DTA114Y)						Unit
		M	E	UA	KA	CA	SA	
V _{CC}	Supply Voltage	-50						V
V _{IN}	Input Voltage	-40~+6						V
I _O	Output Current	-70						mA
I _{CM}	Peak Collector Current	-100						mA
P _D	Power Dissipation	100	150	200	200	200	300	mW
T _J ,T _{stg}	Operation Junction and Storage Temperature Range	-55~+150						°C

ELECTRICAL CHARACTERISTICS (Ta=25°C unless otherwise specified)

Parameter	Symbol	Conditions	Min	Typ	Max	Unit
Input voltage	V _{I(off)}	V _{CC} =-5V,I _O =-100μA	-0.3			V
	V _{I(on)}	V _O =-0.3V,I _O =-1 mA			-1.4	V
Output voltage	V _{O(on)}	I _O /I _I =-5mA/-0.25mA			-0.3	V
Input current	I _I	V _I =-5V			-0.88	mA
Output current	I _{O(off)}	V _{CC} =-50V,V _I =0			-0.5	μA
DC current gain	G _I	V _O =-5V,I _O =-5mA	68			z
Input resistance	R ₁		7	10	13	kΩ
Resistance ratio	R ₂ /R ₁		3.7	4.7	5.7	
Transition frequency	f _T	V _O =-10V,I _O =-5mA,f=100MHz		250		MH

Typical Characteristics

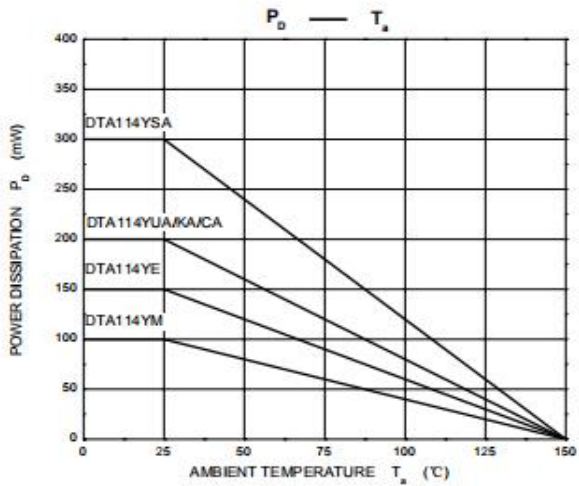
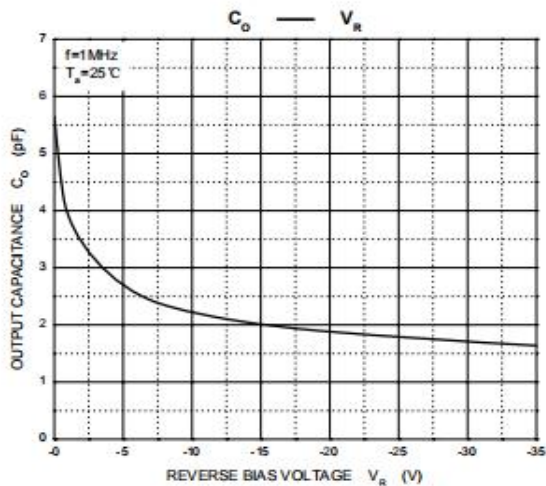
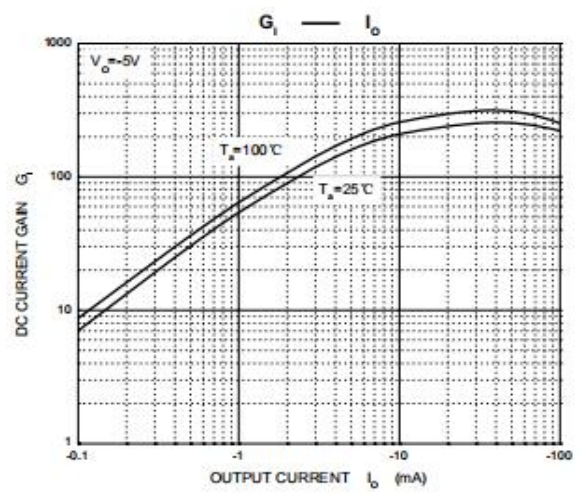
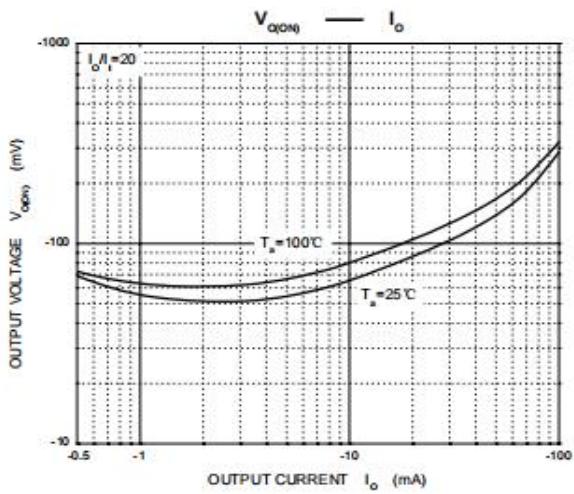
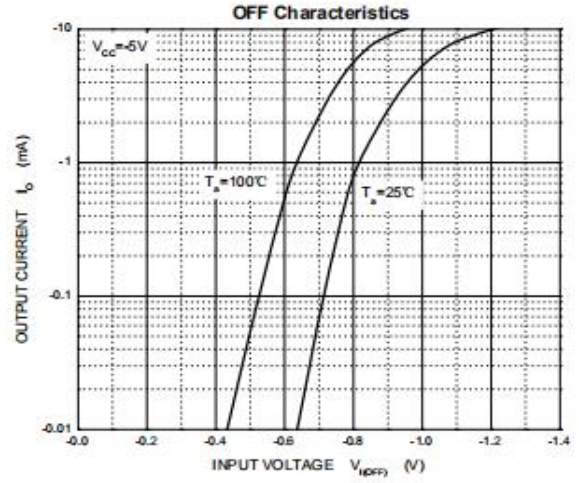
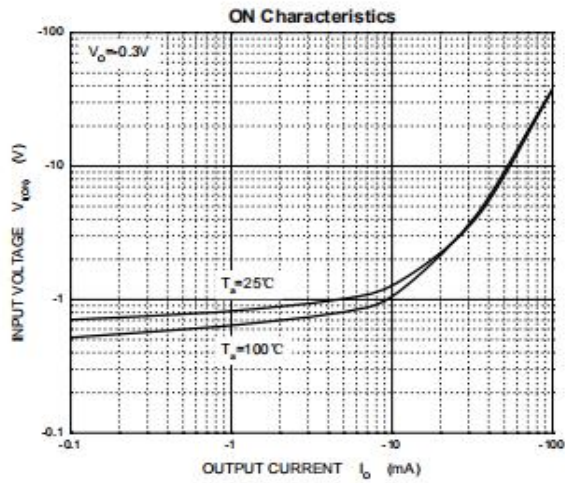

REVERSE VOLTAGE V_R (V) AMBIENT TEMPERATURE T_s ($^\circ C$)

PACKAGE OUTLINE

Plastic surface mounted package; 3 leads

SOT-523

PACKAGE OUTLINE

Plastic surface mounted package; 3 leads

SOT-323

Package outline dimensions SOT23-3L

PACKAGE OUTLINE

Plastic surface mounted package; 3 leads

SOT-23

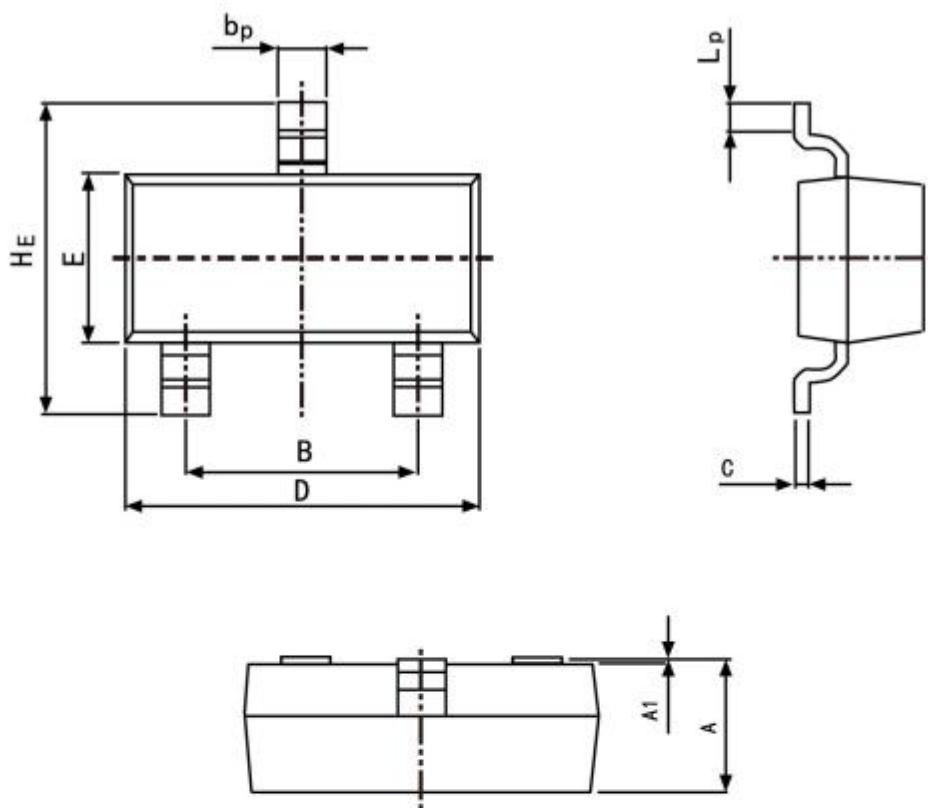

Symbol	Dimension in Millimeters	
	Min	Max
A	0.95	1.40
B	1.78	2.04
b_p	0.35	0.50
C	0.08	0.19
D	2.70	3.10
E	1.20	1.65
HE	2.20	3.00
A_1	0.100	0.013
L_p	0.20	0.50

X-ON Electronics

Largest Supplier of Electrical and Electronic Components

Click to view similar products for [Bipolar Transistors - Pre-Biased](#) category:

Click to view products by [Hong Kong Chuangji](#) manufacturer:

Other Similar products are found below :

[DRC9A14E0L](#) [DTA124GKAT146](#) [DTA144WETL](#) [DTA144WKAT146](#) [DTC113EET1G](#) [DTC115TETL](#) [DTC115TKAT146](#)
[DTC144VUAT106](#) [MUN5241T1G](#) [BCR158WH6327XTSA1](#) [SMUN5330DW1T1G](#) [RN1306\(TE85L,F\)](#) [EMH15T2R](#) [NSBC143ZPDP6T5G](#)
[DTC114EUA-TP](#) [SMUN5237DW1T1G](#) [SMUN5213DW1T1G](#) [SMUN5114DW1T1G](#) [DTC124ECA-TP](#) [DTA114ECA-TP](#) [DTC113EM3T5G](#)
[NSVMUN5135DW1T1G](#) [NSVMUN2237T1G](#) [NSVDTC143ZM3T5G](#) [SMUN5335DW1T2G](#) [SMUN5216DW1T1G](#) [NSVMUN5316DW1T1G](#)
[NSVMUN5215DW1T1G](#) [NSVMUN5213DW1T3G](#) [NSVIMD10AMT1G](#) [NSVEMC2DXV5T1G](#) [NSVDTC144WET1G](#) [NSVDTC123JET1G](#)
[NSVDTA143EM3T5G](#) [NSVB1706DMW5T1G](#) [NSBC143EDP6T5G](#) [NSBA144WDXV6T1G](#) [DTA115TET1G](#) [NSBC115TDP6T5G](#)
[NSBA113EF3T5G](#) [MUN2235T1G](#) [NSBC143ZDXV6T5G](#) [NSVDTA114EM3T5G](#) [MUN2138T1G](#) [DCX124EUQ-7-F](#) [MUN2141T1G](#)
[DTC144TET1G](#) [MUN2238T1G](#) [SMUN5112DW1T1G](#) [NSVMUN5131T1G](#)